



US009155923B2

(12) **United States Patent**
Proctor

(10) **Patent No.:** **US 9,155,923 B2**
(45) **Date of Patent:** **Oct. 13, 2015**

(54) **PORTABLE RESPIRATORS SUITABLE FOR AGRICULTURAL WORKERS**

(75) Inventor: **Michele Lea Proctor**, Raleigh, NC (US)

(73) Assignee: **East Carolina University**, Greenville, NC (US)

(*) Notice: Subject to any disclaimer, the term of this patent is extended or adjusted under 35 U.S.C. 154(b) by 980 days.

(21) Appl. No.: **13/312,453**

(22) Filed: **Dec. 6, 2011**

(65) **Prior Publication Data**

US 2013/0139816 A1 Jun. 6, 2013

(51) **Int. Cl.**

A62B 18/02 (2006.01)
A62B 18/08 (2006.01)
A41D 13/11 (2006.01)
A62B 18/00 (2006.01)

(52) **U.S. Cl.**

CPC **A62B 18/02** (2013.01); **A41D 13/1161** (2013.01); **A41D 13/1184** (2013.01); **A62B 18/003** (2013.01); **A62B 18/08** (2013.01)

(58) **Field of Classification Search**

CPC **A62B 7/10**; **A62B 18/02**; **A62B 18/025**; **A62B 18/04**; **A62B 18/045**; **A62B 18/06**; **A62B 18/08-18/10**; **A62B 23/02**; **A62B 23/025**; **A61M 16/0683**; **A61M 16/0694**
See application file for complete search history.

(56) **References Cited**

U.S. PATENT DOCUMENTS

3,822,698 A 7/1974 Guy
3,971,373 A 7/1976 Braun
4,133,308 A 1/1979 Lowe et al.
4,136,688 A 1/1979 Gorman

4,157,090 A 6/1979 Phillips
4,280,491 A 7/1981 Berg et al.
4,462,399 A 7/1984 Braun
4,674,136 A 6/1987 Ladewig
4,752,974 A 6/1988 Haino
4,764,990 A * 8/1988 Markert 2/429
4,852,562 A 8/1989 Howie
5,035,239 A 7/1991 Edwards
5,054,479 A 10/1991 Yelland et al.
5,104,430 A 4/1992 Her-Mou
5,427,092 A 6/1995 Shiao
5,533,500 A 7/1996 Her-Mou
5,561,862 A 10/1996 Flores, Sr.
5,577,495 A 11/1996 Murphy
5,666,663 A * 9/1997 Bolle 2/10

(Continued)

OTHER PUBLICATIONS

Proctor, Michele Lea, Farmor: A case study in design and agriculture, Thesis, Dec. 10, 2010, pp. 1-33 (of 46 total), pp. 18-22, 29-33 describe or show pictures of third party designs that existed prior to Dec. 10, 2010.

(Continued)

Primary Examiner — Valerie L Skorupa
(74) *Attorney, Agent, or Firm* — Myers Bigel Sibley & Sajovec, P.A.

(57) **ABSTRACT**

Portable personal respiratory protection devices include a self-contained head gear member with a chin collar that has a front segment that defines a mouth portion and attaches to a back segment that resides over ears of a user and extends about a lower back segment of a head of the user. The head gear includes a visually transmissive face mask extending upwardly from the front segment of the chin collar that, in position, sealably engages a face of the user. The head gear has an open upper portion residing between an outer upper perimeter of the face mask and the back segment of the chin collar that, when worn, is adapted to expose a top and upper rear portion of a head of the user to environmental conditions.

17 Claims, 7 Drawing Sheets

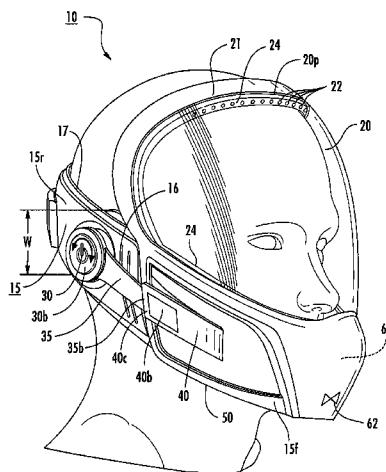

(56)

References Cited

OTHER PUBLICATIONS

U.S. PATENT DOCUMENTS

5,687,713 A 11/1997 Bahr et al.
 D388,872 S 1/1998 Grannis et al.
 5,720,281 A 2/1998 Allen et al.
 5,758,639 A 6/1998 Ikonen
 5,966,746 A 10/1999 Reedy et al.
 6,014,971 A 1/2000 Danisch et al.
 6,035,451 A 3/2000 Burns et al.
 6,081,929 A 7/2000 Rothrock et al.
 6,102,033 A 8/2000 Baribeau et al.
 6,104,816 A 8/2000 Downs, Jr. et al.
 6,121,881 A 9/2000 Bieback et al.
 6,250,299 B1 6/2001 Danisch et al.
 6,263,513 B1 7/2001 Murakami
 6,279,572 B1 8/2001 Danisch et al.
 6,381,749 B1* 5/2002 Cyr 2/9
 6,382,208 B2 5/2002 Reedy et al.
 6,481,019 B2 11/2002 Diaz et al.
 6,622,311 B2 9/2003 Diaz et al.
 6,766,537 B1 7/2004 Maki et al.
 D503,497 S 3/2005 Canavan et al.
 6,886,559 B2* 5/2005 McDonald et al. 128/201.24
 6,904,616 B1 6/2005 Maki et al.
 6,918,141 B2 7/2005 Green et al.
 6,925,655 B1 8/2005 Maki et al.
 6,942,098 B1 9/2005 Dodge
 6,961,963 B2 11/2005 Rosie
 6,973,677 B2 12/2005 Diaz et al.
 6,990,691 B2 1/2006 Klotz et al.
 7,036,502 B2 5/2006 Manne
 7,055,521 B1 6/2006 Johnson
 7,104,264 B2 9/2006 Lee et al.
 7,114,194 B2 10/2006 English
 7,197,774 B2 4/2007 Curran et al.
 7,200,873 B2 4/2007 Klotz et al.
 7,392,806 B2* 7/2008 Yuen et al. 128/205.27
 7,471,062 B2 12/2008 Bruning
 7,523,750 B2 4/2009 Krzysztofik
 7,594,510 B2 9/2009 Betz et al.
 D602,154 S 10/2009 Ono et al.
 7,616,774 B2 11/2009 Lazzeroni et al.
 7,633,263 B2 12/2009 Toya
 7,655,070 B1 2/2010 Dallas et al.
 7,708,816 B2 5/2010 Holmes et al.
 7,717,975 B2 5/2010 Kalayci et al.
 7,752,682 B2 7/2010 VanDerWoude et al.
 7,802,318 B2 9/2010 Chen
 7,823,586 B2 11/2010 Glazman
 7,878,195 B2 2/2011 Alvey et al.
 7,907,975 B2 3/2011 Sakamoto et al.
 7,918,913 B2 4/2011 Kalayci et al.
 7,922,796 B2 4/2011 Holmes et al.
 7,934,497 B1 5/2011 Grove et al.
 7,937,779 B2 5/2011 Klotz et al.
 7,958,573 B2 6/2011 Lewis, Jr. et al.
 7,988,860 B2 8/2011 Kalayci et al.
 8,011,026 B2 9/2011 Stevens
 D700,962 S 3/2014 Lavoie
 D702,831 S 4/2014 Lavoie
 D704,327 S 5/2014 Lavoie
 D704,328 S 5/2014 Lavoie
 D706,414 S 6/2014 Lavoie
 2005/0036100 A1* 2/2005 Rice et al. 351/62
 2005/0278833 A1 12/2005 Pierce
 2006/0213523 A1 9/2006 VanDerWoude et al.
 2008/0087282 A1 4/2008 Torgerson
 2010/0069002 A1 3/2010 Rong
 2010/0095439 A1 4/2010 Nolan et al.
 2012/0174922 A1* 7/2012 Virr et al. 128/203.12

3M™ Particulate Respirator; Product Information, MSC Industrial Supply Co.; 1 page; Printed from Internet on May 10, 2012, but for the purpose of examination, publication date believed to be prior to Dec. 6, 2011; www.1.msdirect.com/popupcode.html.
 Fastenal®; Light Duty Dust Mask w/ Single Elastic Fixed Strap—50Ct by BodyGuard Safety Gear; © 2012 Fastenal Co.; Product Information; 1page; www.Fastenal.com/web/products/detail.ex?sku=1006989.
 3M™ 6000 Series HalfFace Respirator with P100 Particulate Filters; Product Information, Zeflon International; 1 page; Printed from internet on May 10, 2012, but for the purpose of examination; publication date believed to be prior to Dec. 6, 2011; www.zefon.com/store/3m-6000-series-half-face-respirator-with-p100-particulate-filter.
 3M™ Half Facepiece Respirators 7500 Series, Ultimate Reusable; Product Information Manual; 3 pages; Issue Date Jan. 1, 2004.
 3M™ 6000 Series Full Face Paint Spray Pesticide Respirator; Product Information; Enviro Safety Products; 1page; printed from internet on May 10, 2012 but for the purpose of examination, publication date believed to be prior to Dec. 6, 2011; www.envirosafetyproducts.com/3m-6000-series-full-facepiece-paint-spray-pesticide-respirator.
 3M™ RBE Loose Fitting Powered Air Purifying Respirator(PAPR) System NIOSH CBRN PAPR Approved; (models RBE-NM10, RBE-L10) Product Manual, 3 pages © 2007.
 3M™ Air-Mate™ Self-Contained Breathing Apparatus (SCBA), Product Information Manual; 8 pages; © 2001.
 3M™ 7000 Reusable Respirators; product information; 1 page; printed from the internet on May 10, 2012 but for the purpose of examination, publication date believed to be prior to Dec. 6, 2011; www.uline.com/BL_1092/3M-7000-Reusable-Respirators.
 3M™ 6000 Reusable(Full Face) Respirators; product information; 1 page; printed from the internet on May 10, 2012 but for the purpose of examination, publication date believed to be prior to Dec. 6, 2011; www.uline.com/BL_992/3M-6000-Reusable-Respirators.
 3M™ Head Harness Replacement 6897, 3M™ Lens Assembly 6898 and 3M™ Frame Kit 6899; 2 pages; Product Information; © 2007.
 3M™ Versaflo™ Easy Clean PAPR Kit TR-300-ECK; Product Information; 2 pages; printed from the internet on May 10, 2012 but for the purpose of examination, publication date believed to be prior to Dec. 6, 2011; http://solutions.3M.com/wps/portal/3M/en_US/PPESafetySolutions/PPESafety/Personal.
 3M™ Breathe Easy Turbo PAPR Assembly; Product Information; 47 pages; © 2009.
 Trend® Airshield Air Circulating Face Shield; Product Manual; 17 pages ©Trend 2004.
 Airshield Pro Complete Package; Product information; 1 page; © 2004-2009; <http://store.trendairshield.com/airprounac.htm.l>.
 Original Airshield and Accessories; Product information; 1 page; printed from the internet on May 10, 2012 but for the purpose of examination, publication date believed to be prior to Dec. 6, 2011; © 2004-2009; <http://store.trendairshield.com/oraiac.html>.
 Lenhart, Steven W., "Respirator Selection Guidance for Poultry Growers." Poultry Grower News, Sep. 12, 1996, pp. 12-14.
 Chai, Ming et al. "Using an Improved Electrostatic Precipitator for Poultry Dust Removal"; Journal of Electrostatics 67.6 (2009), pp. 870-875 Science Direct. Web. Abstract Only, Apr. 2010.
 Malone, George W & Ronald C. Jester. Respiratory Health on the Poultry Farm. National Ag. Safety Database, 4 pages, Jan. 2003. <<http://nasdonline.org/document/197/d000146/respiratory-health-on-the-poultry-farm.html>>.
 WSDLI, Key Information about NIOSH Certified Respirators. Washington State Department of Labor and Industries, 4 pages, Dec. 2009., <http://www.lni.wa.gov/WISHA/Rules/respirators/PDF's/HT3-Resources.pdf>.

* cited by examiner

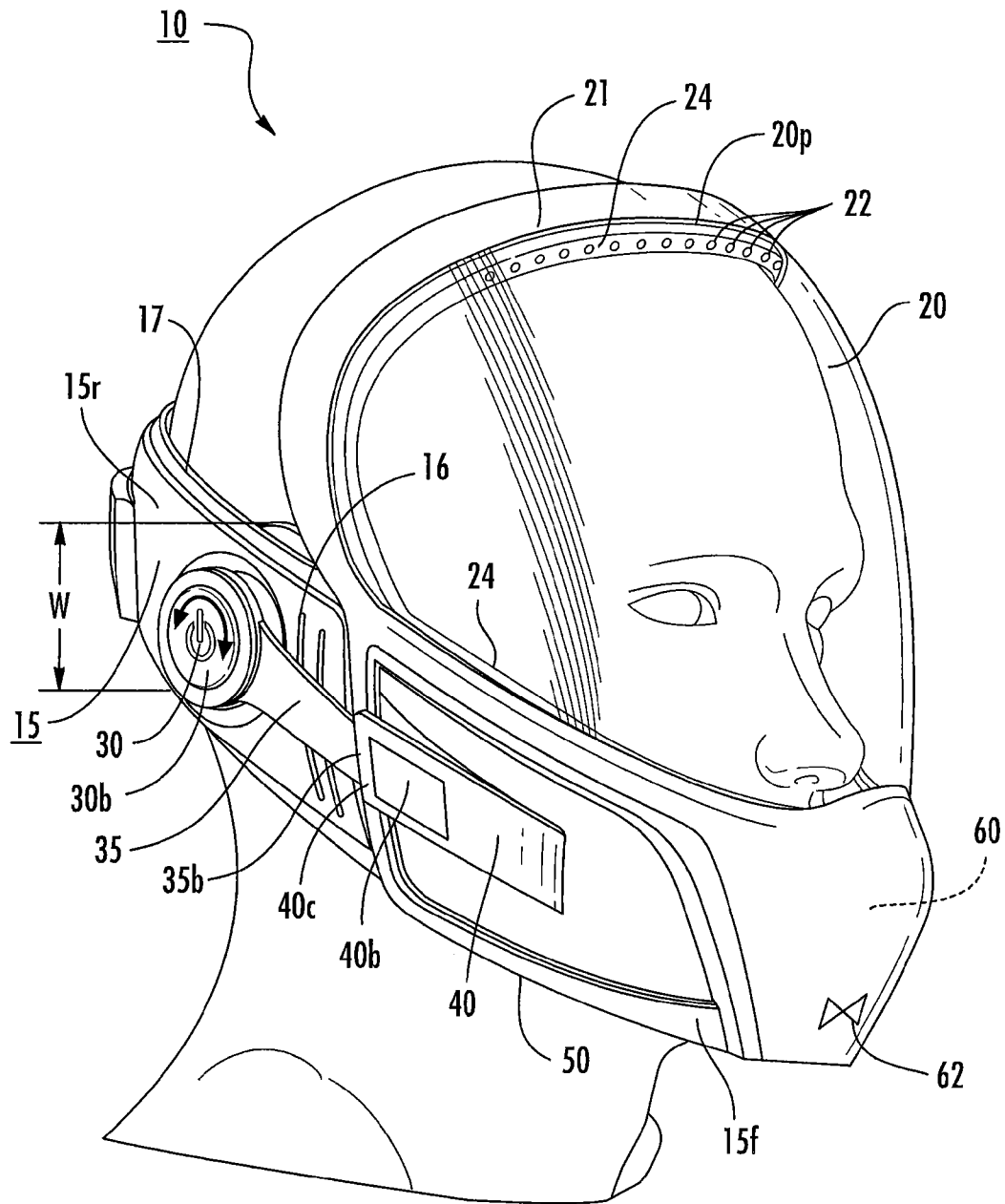
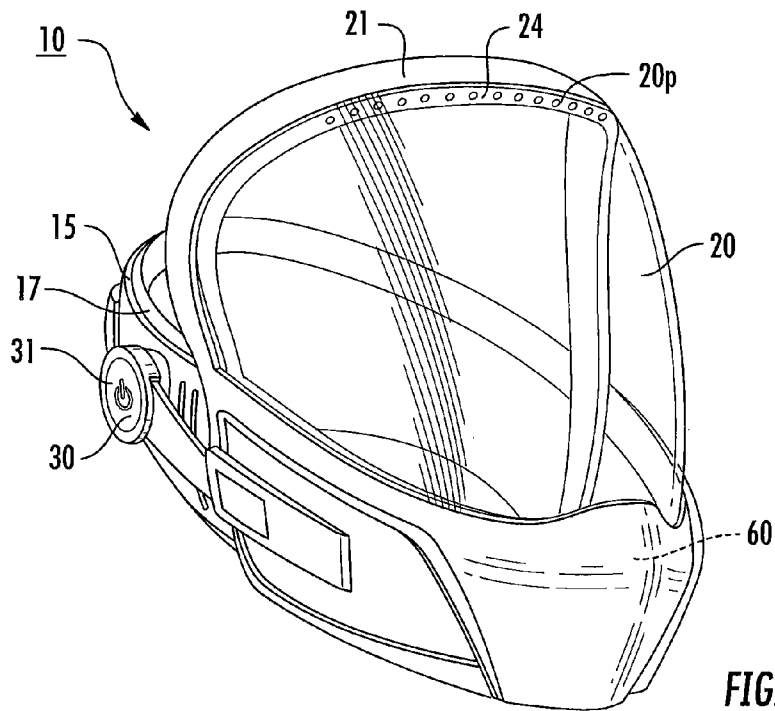
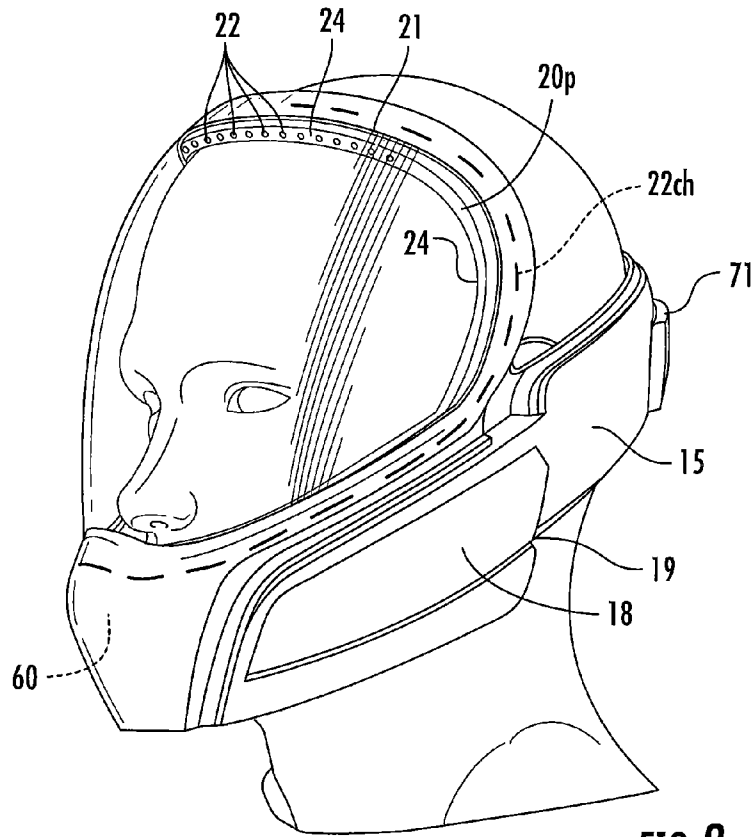

FIG. 1



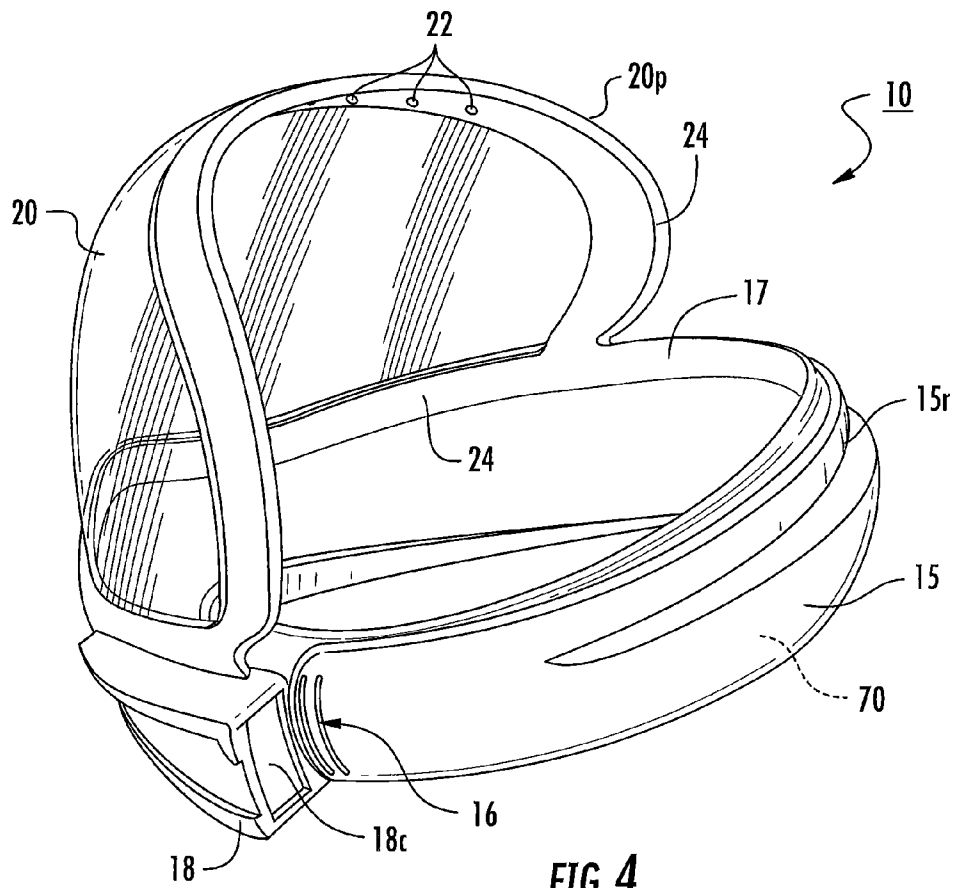

FIG. 4

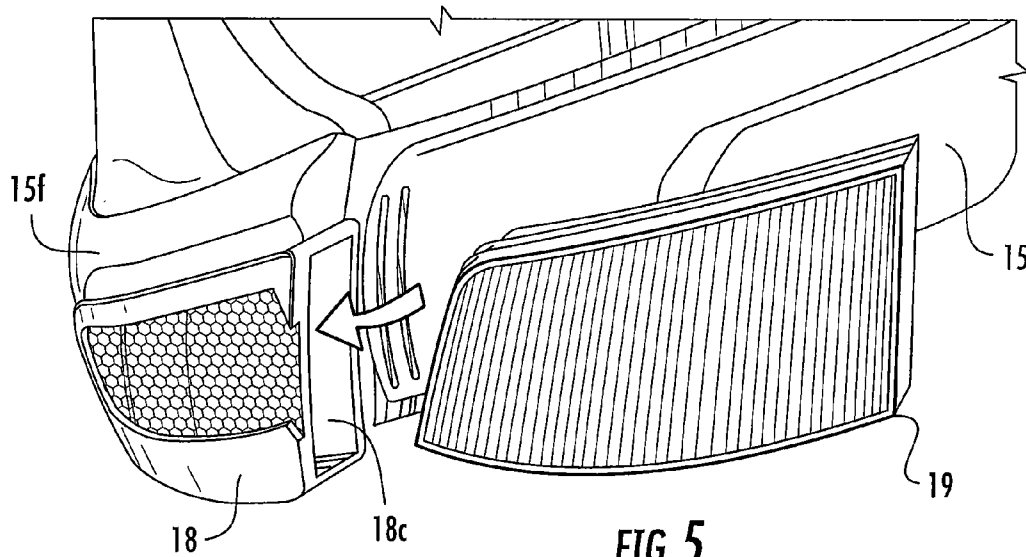

FIG. 5

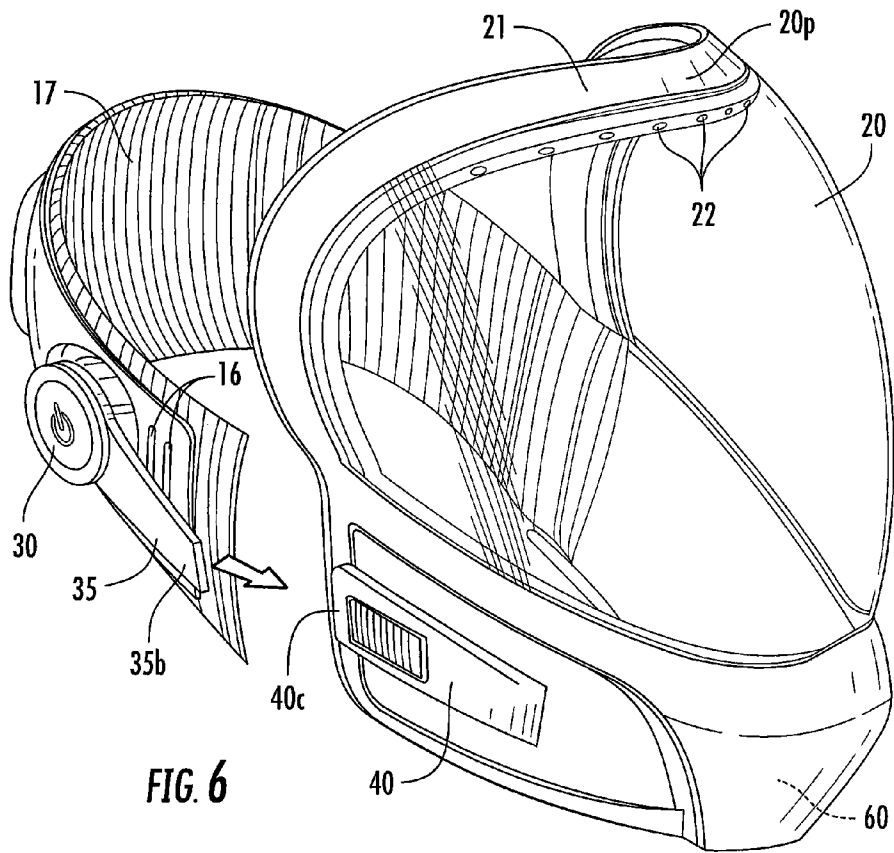

FIG. 6

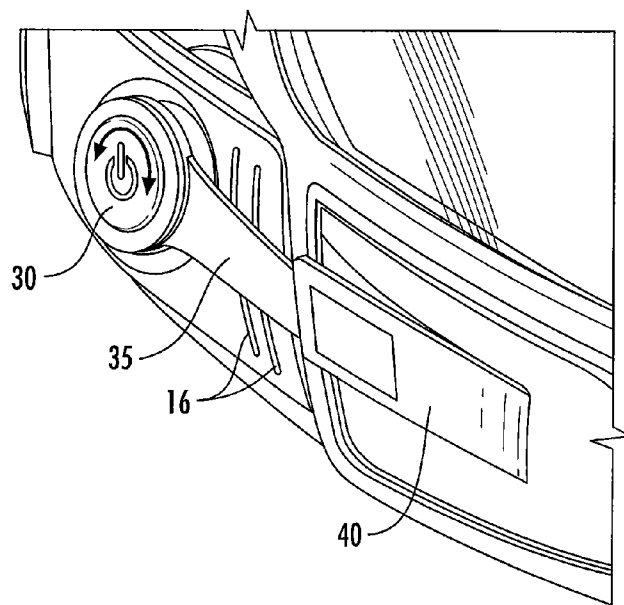
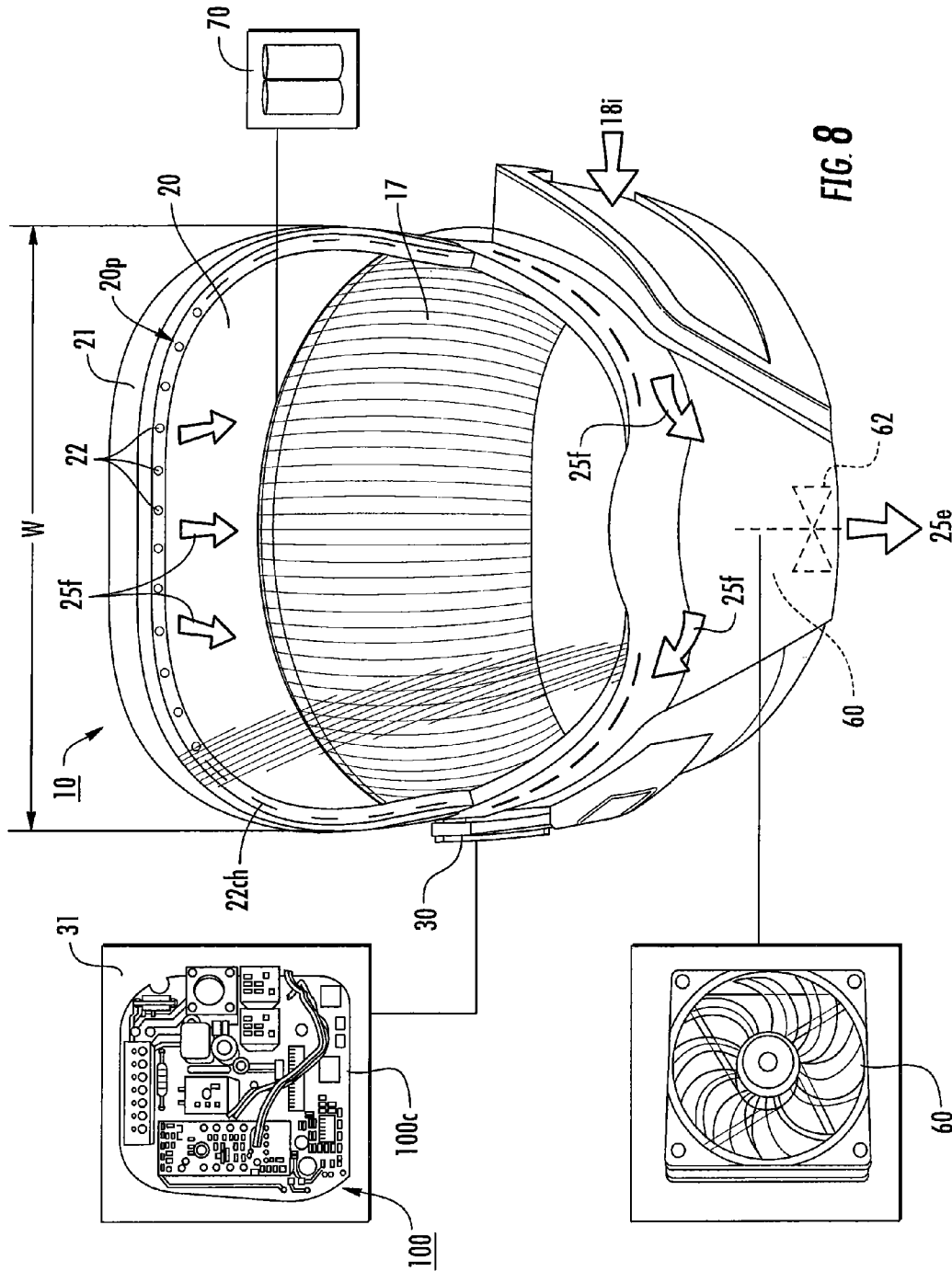

FIG. 7



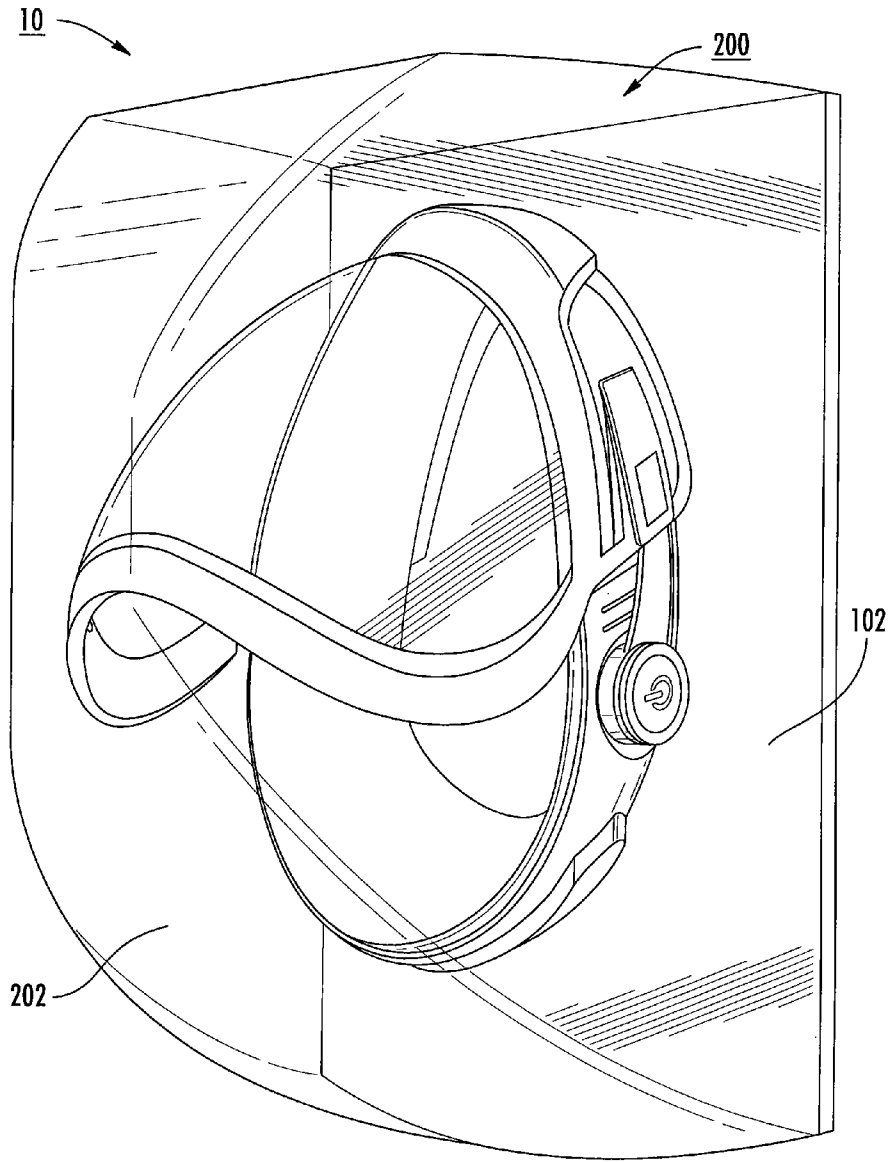

FIG. 9

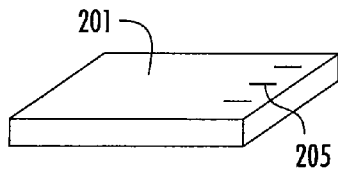

FIG. 10

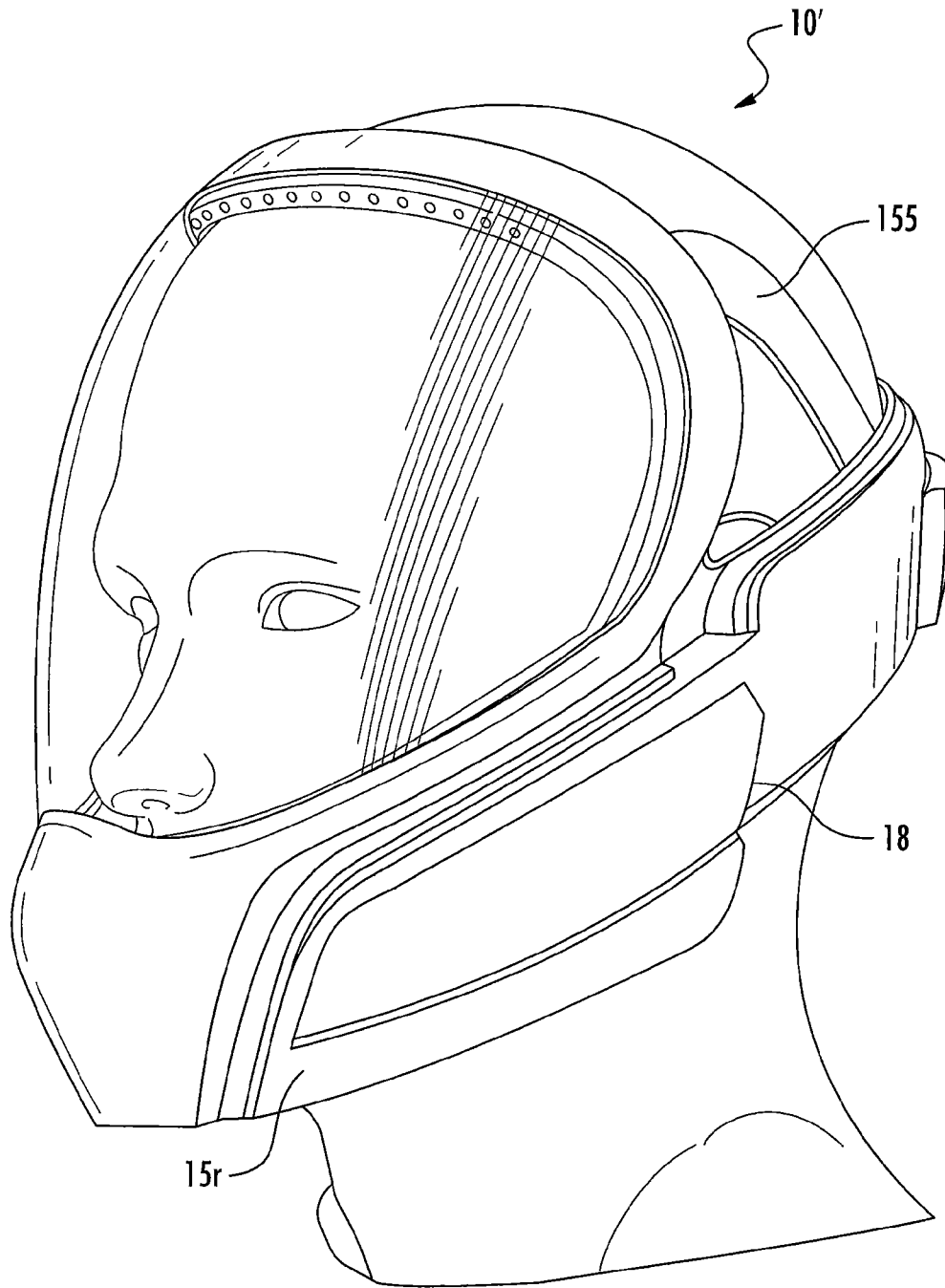

FIG. 11

PORTABLE RESPIRATORS SUITABLE FOR AGRICULTURAL WORKERS

FIELD OF THE INVENTION

The invention relates to respirators suitable for agricultural workers.

BACKGROUND

The poultry industry has grown significantly over the past decade. There are emerging medical studies that show the health risks and effects of confined poultry work environments on workers. Farmers and other workers with prolonged exposure, e.g., five years or more of almost daily contact, are at a greater risk for respiratory complications and disease. In addition, agricultural workers can be exposed to other occupational hazards, such as heat-related deaths. Comfort and heat issues can be significant factors that determine whether workers wear suitable protective gear or not.

There remains a need for light-weight respirators that are suitable for agricultural use and that are configured to facilitate long term, chronic use of those respirators to inhibit occupational exposure to airborne particulates.

SUMMARY OF EMBODIMENTS OF THE INVENTION

Embodiments of the present invention are directed to portable respiratory protection devices suitable for many uses, but particularly suitable for agricultural uses.

Some embodiments of the present invention are directed to portable personal respiratory protection devices. The devices include a self-contained head gear member with a chin collar that has a front segment that defines a mouth portion and attaches to a back segment that resides over ears of a user and extends about a lower back segment of a head of the user. The back segment of the chin collar includes a first locking member that is sized and configured to releasably engage a second cooperating locking member on the front segment of the chin collar for locking engagement and/or size adjustment of the chin collar. The devices also include a visually transmissive face mask extending upwardly from the front segment of the chin collar that, in position, sealably engages a face of the user. The head gear has an open upper portion residing between an outer upper perimeter of the face mask and the back segment of the chin collar that, when worn, is adapted to expose a top and upper rear portion of a head of the user to environmental conditions. The device also includes a filter chamber in the chin collar configured to releasably receive a filter for air intake and a plurality air flow ports residing across the upper portion of the perimeter of the face mask to direct cooling air into the face mask.

The face mask outer perimeter can include a curvilinear frame that rises from opposing sides of the front segment of the chin collar and terminates at an upper portion that extends above a brow line across a forehead of the user.

The device can further include an inner sealant material attached to the frame and the forward portion of the chin collar. The air flow ports can be defined in an upper portion of the inner sealant material.

The device can include a fan held in the front segment of the chin collar in fluid communication with the air flow exit ports, a wireless communication circuit held in the chin collar, and a power source held in the chin collar, the power source configured to power the fan and the wireless communication circuit.

The wireless communication circuit can include a BLUE-TOOTH circuit.

The chin collar can releasably hold the filter on one side of the front segment of the chin collar. The second locking member can be on an opposing side of the front segment of the chin collar.

The front section of the chin collar has a width such that a lowermost portion resides above a neck of the user proximate a chin of the user and an uppermost portion terminates proximate but under a nose of the user. The visually transmissive face mask defines a wide field of view. The back segment of the chin collar has a substantially constant width of between about 1.5-3.5 inches.

The back segment of the chin collar can include a padding layer that extends inside an outer shell of the back segment and has a width sufficient to cover a respective ear of a user. The padding is releasably engaged to the back segment of the chin collar for cleaning or replacement.

The first locking member can be a ratcheting buckle and the second cooperating member can be a receiving shaft and the device can further include a quick release button to allow the buckle to be easily disengaged by a user.

The device can include a power on/off member with an adjustable volume control residing on the back segment of the chin collar proximate an ear of the user.

The back segment can include an outer shell that resides over an inner padding layer. The back segment outer shell can include a plurality of apertures residing proximate each ear portion of the back segment to thereby allow for increased sound penetration.

The device can include a fan residing in a front medial portion of the front segment of the chin collar. The fan can be configured to generate air flow in the device of between about 5-10 cubic feet/minute.

The device can include a battery chamber in the back section of the chin collar for powering the fan.

The device can include an external power activation member residing in the back segment of the chin collar over an internal circuit board and a wireless communication (e.g., Bluetooth) activation member residing in the front segment of the chin collar.

The device can be in combination with a storage unit comprising a battery charging circuit.

The storage unit can be a wall-mount unit having a base that holds the respirator and recharges batteries in the back segment of the chin collar when held thereon.

The storage unit can include a visually transmissive lid that closes to enclose at least one respirator therein.

It is noted that aspects of the invention described with respect to one embodiment, may be incorporated in a different embodiment although not specifically described relative thereto. That is, all embodiments and/or features of any embodiment can be combined in any way and/or combination. Applicant reserves the right to change any originally filed claim or file any new claim accordingly, including the right to be able to amend any originally filed claim to depend from and/or incorporate any feature of any other claim although not originally claimed in that manner. These and other objects and/or aspects of the present invention are explained in detail in the specification set forth below.

BRIEF DESCRIPTION OF THE DRAWINGS

FIG. 1 is a side perspective view of a personal respirator according to embodiments of the present invention.

FIG. 2 is an opposing side perspective view of the device shown in FIG. 1 according to embodiments of the present invention.

FIG. 3 is a side perspective view of the device shown in FIG. 1.

FIG. 4 is a rear side perspective view of the device shown in FIG. 1 according to embodiments of the present invention.

FIG. 5 is an enlarged side perspective view of the device shown in FIG. 4 according to embodiments of the present invention.

FIG. 6 is a front, side perspective view of the device shown in FIG. 1 illustrating a locking engagement of two cooperating members according to embodiments of the present invention.

FIG. 7 is a partial side perspective view of the device shown in FIG. 6 with the two locking members engaged according to embodiments of the present invention.

FIG. 8 is a front schematic illustration of a personal respirator with exemplary air flow circulation and circuit components according to embodiments of the present invention.

FIG. 9 is a front, side perspective view of a personal respirator in a storage unit according to embodiments of the present invention.

FIG. 10 is a side schematic illustration of a base suitable for holding a respirator for recharging batteries according to embodiments of the present invention.

FIG. 11 is a side perspective view of another embodiment of the respirator shown in FIG. 1 according to embodiments of the present invention.

DETAILED DESCRIPTION OF EMBODIMENTS OF THE INVENTION

The present invention will now be described more fully hereinafter with reference to the accompanying figures, in which preferred embodiments of the invention are shown. This invention may, however, be embodied in many different forms and should not be construed as limited to the embodiments set forth herein.

Like numbers refer to like elements throughout. In the figures, layers, regions, or components may be exaggerated for clarity. Broken lines illustrate optional features or operations unless specified otherwise.

The terminology used herein is for the purpose of describing particular embodiments only and is not intended to be limiting of the invention. As used herein, the singular forms “a,” “an” and “the” are intended to include the plural forms as well, unless the context clearly indicates otherwise. It will be further understood that the terms “comprises” and/or “comprising,” when used in this specification, specify the presence of stated features, integers, steps, operations, elements, and/or components, but do not preclude the presence or addition of one or more other features, integers, steps, operations, elements, components, and/or groups thereof. As used herein, the term “and/or” includes any and all combinations of one or more of the associated listed items. As used herein, phrases such as “between X and Y” and “between about X and Y” should be interpreted to include X and Y. As used herein, phrases such as “between about X and Y” mean “between about X and about Y.” As used herein, phrases such as “from about X to Y” mean “from about X to about Y.”

Unless otherwise defined, all terms (including technical and scientific terms) used herein have the same meaning as commonly understood by one of ordinary skill in the art to which this invention belongs. It will be further understood that terms, such as those defined in commonly used dictionaries, should be interpreted as having a meaning that is

consistent with their meaning in the context of the specification and relevant art and should not be interpreted in an idealized or overly formal sense unless expressly so defined herein. Well-known functions or constructions may not be described in detail for brevity and/or clarity.

It will be understood that when an element is referred to as being “on,” “attached” to, “connected” to, “coupled” with, “contacting,” etc., another element, it can be directly on, attached to, connected to, coupled with or contacting the other element or intervening elements may also be present. In contrast, when an element is referred to as being, for example, “directly on,” “directly attached” to, “directly connected” to, “directly coupled” with or “directly contacting” another element, there are no intervening elements present. It will also be appreciated by those of skill in the art that references to a structure or feature that is disposed “adjacent” another feature may have portions that overlap or underlie the adjacent feature.

It will be understood that, although the terms first, second, etc. may be used herein to describe various elements, components, regions, layers and/or sections, these elements, components, regions, layers and/or sections should not be limited by these terms. These terms are only used to distinguish one element, component, region, layer or section from another region, layer or section. Thus, a first element, component, region, layer or section discussed below could be termed a second element, component, region, layer or section without departing from the teachings of the present invention. The sequence of operations (or steps) is not limited to the order presented in the claims or figures unless specifically indicated otherwise.

Spatially relative terms, such as “under,” “below,” “lower,” “over,” “upper” and the like, may be used herein for ease of description to describe one element or feature’s relationship to another element(s) or feature(s) as illustrated in the figures. It will be understood that the spatially relative terms are intended to encompass different orientations of the device in use or operation in addition to the orientation depicted in the figures. For example, if a device in the figures is inverted, elements described as “under” or “beneath” other elements or features would then be oriented “over” the other elements or features. Thus, the exemplary term “under” can encompass both an orientation of over and under. The device may be otherwise oriented (rotated 90 degrees or at other orientations) and the spatially relative descriptors used herein interpreted accordingly. Similarly, the terms “upwardly,” “downwardly,” “vertical,” “horizontal” and the like are used herein for the purpose of explanation only unless specifically indicated otherwise.

The term “chin collar” refers to a band-like member that substantially encircles the head at a location proximate the mandible.

The term “agricultural” and derivatives thereof refers to farming environments, including, for example, livestock, dairy, poultry, fish, timber and crops. Embodiments of the present invention are particularly suitable for agricultural use, including poultry confinement environments. However, other uses of the devices are contemplated, particularly where airborne contaminants or particulates or other air-quality issues may be of concern, including, for example, slaughter houses and meat or grain processing plants, oil drilling, and the like. The devices may also be suitable for other uses including medical, such as surgical, nursing or hospital uses (such as for contagious wards or rooms) and dental uses. The devices may also be suitable for research laboratory uses, research uses, police or private protection uses, for applying pesticides or fertilizers, garbage collectors, military uses, manufacturing

uses, including production or devices and chemicals, paint booths, and the like, and for woodworkers and welders and the like.

FIGS. 1-8 illustrate an exemplary respirator 10. The respirator 10 can be a self-contained, head-supported (headgear) device. There is no need for any belt packs, oxygen tanks or other components. The respirator 10 can be light weight, relatively easy to put on, and can provide protection against airborne particulates. The respirator 10 includes a chin collar 15 that supports a face mask 20 (also described as a “shield”); e.g., the face mask 20 extends upwardly from the chin collar 15. The respirator face mask 20 is sealably attached to a face of a user. The mask 20 may optionally be configured to accommodate a user’s eyeglasses. In some embodiments, the mask 20 can be configured to allow a customized lens portion for vision.

The respirator 10 can also include a power core 30, a cooling source such as a fan 60, an air filter 19 (FIG. 2) and have Bluetooth capability. The respirator 10 includes a head gear member that defines an open (helmetless) top that exposes the top and top rear of the head, is less-restrictive than conventional helmet-based products and may reduce heat loads induced by some conventional respirators.

The face shield 20 can be configured to provide a wide field of view (FOV) for improved visibility. The term “wide FOV” refers to a FOV that allows wider peripheral vision, typically about 180 degrees (90 degrees to each side of the head). The mask 20 can be configured to have minimal contact with a face, in that the only contact is around the outer seal in the face mask and front segment of the chin collar; there is no nose or mouth contact while providing full face protection with a wide shield for maximum visibility. The respirator 10 does not typically provide full sound protection, but is configured to provide some auditory filtering, in order to hear while using heavy equipment, but the designs also allow for additional use of ear plugs for full sound protection.

The respirator 10 can be provided as a one-size-fits-all device. More typically, the respirator 10 can be provided in an assortment of sizes, such as S, M, L, XL or other size combinations with different size shields 20 and chin collars 15.

The respirator 10 can with all operational components included (e.g., batteries, filter, fan and padding), have a weight that is under about 3.0 pounds, typically under about 2.0 pounds, and in some embodiments between about 0.75 pounds to about 1.5 pounds, such as about 1 pound.

The face mask 20 can comprise a double-paned thermal visor material, typically clear, but opaque, color, tinted or other visually transmissive materials may be used to inhibit fogging and can serve as two layers of face protection from impact. However, other transmissive materials may be used. Peel-away external film layers may also be used.

The chin collar 15 can allow for some sizing adjustment to facilitate a variety of different size users. The chin collar 15 can be configured to have a single hinge, and the respirator 20 does not require any elastic head straps to support the mask 20 which could get tangled on equipment or environmental items. FIG. 11 illustrates another embodiment of the respirator 10’ which includes a supplemental support member 155. This member 155 may be elastic and/or polymeric, but does not typically extend over the top of the head of the user.

The face mask 20 can include an interior seal material 24 which is typically a conformable material that snugly abuts a face of the user and resides between the mask or shield 20 and the face of the user. The face mask 20 can sealably attach to the face of a user, e.g., via a pressure lock. Opposing pressure from either side of the face mask 20 and/or against the face of a user can click the mask tighter on the face to ensure a tight

fit. The material 24 in the face mask 20 can define substantially O-shaped seal around the face which can create a double seal effect when put into compression. The O-shaped seal can extend across the upper perimeter of the frame/mask 20, down along outer side portions thereof (across the cheeks) and inside the front segment of the chin collar proximate the cheeks and above the chin, typically above the lips of the user. The material 24 can comprise silicone; the use of silicone instead of rubber increases wearer comfort and can be less rigid and inhibit face gouging.

The shield 20 has an upper perimeter 20p that can be encased by a frame 21. The upper portion of the visually transmissive material of the shield 20 can be sealably attached to the frame 21. The frame 21 can have a relatively short width (measured side to side on the sides or top to bottom on the top) of between about 0.25 inches to about 3 inches, typically between about 1-2 inches. Under the upper perimeter of the mask 20p are a plurality of spaced apart air flow outlets 22 that reside across at least a major portion of the span of the upper perimeter portion of the face mask 20. These air flow outlets 22 are in fluid communication with an active cooling source such as a fan 60 and direct cooling air into the face shield volume of the respirator 10. The air flow outlets 22 can be formed in the material 24. Fluid channels 22ch as internal duct work (FIG. 2, 8) can be in fluid communication with the fan 60 and extend through the chin collar 15, up the side of the face mask 20 or frame 21, then to the outlets 22 to direct a volume of cooling air into the face mask 20.

The chin collar 15 can include a front segment 15f that supports the shield or mask 20 and a back segment 15r. The back segment 15r can lockingly engage the front segment 15f. The back segment 15r can have a width “W” sufficient to cover substantially all of the respective ear of a user. Typically, the width W substantially corresponds to a length of the ear of a user (on average), such that typically W is between about 1.5 inches to about 3.5 inches. The width of the back segment 15r can be substantially constant. The chin collar 15 can comprise a semi-rigid polymeric material such as polycarbonate. Padding 17 can be provided under at least the back segment of the chin collar 15. The padding 17 can be a continuous strip of conformable material such as foam that can be washed and/or replaced when dirty. The padding 17 can also have a width that is sufficient to cover the ear of a user, and may be slightly larger or smaller than the corresponding chin collar 15r. The padding 17 can be releasably attached to the chin collar 15 via VELCRO, adhesive or other holding configurations.

The chin collar 15 proximate the ear of a user can include at least one slot, typically a plurality of slots 16 that provides some hearing protection while also allowing some sound to penetrate to the ears of the wearer. This can be important when a user needs to be able to hear to monitor operational equipment sounds and the like, but the ears are protected from debris and louder sounds.

The back segment 15r of the chin collar 15r be more flexible than the forward portion 15f by being thinner or formed of a different material than the front 15f. The back segment 15r can include an elongate strap 35 that releasably engages the front segment of the shield 15f. The strap 35 can comprise a ratcheting buckle 35b that projects forward to securely (typically lockingly) engage a channel 40c in the front segment of the chin collar 15. The chin collar 15 can include a release member 40b such as a quick-release button that allows a user to disengage the strap 35 to remove the respirator 10. While the respirator is shown as using only one locking member 35 on one side, it is contemplated that both

sides of the chin collar **15** can include a locking member that releasably engages the respective ends of the front segment **15f**.

The respirator **10** can include a power activation button **30b** and a wireless communication (e.g., Bluetooth®) activation device **50** that is externally accessible by a user. As shown in FIG. 1, the activation device **50** can be a push button residing on a lower edge of the chin collar **15**. The wireless communication activation device **50** can be located at other positions of the respirator as well. The wireless transceiver, e.g., Bluetooth transceiver, can be held in the power core **30** or at other suitable locations. The wireless communication circuit allows a user to communicate with others without removing the respirator **10** (for example, respirator **10** to respirator **10** or via a cellular phone). The wireless communication can comprise a Bluetooth® circuit, which is an open wireless technology standard for exchanging data over short distances (using short wavelength radio transmissions in the ISM band from 2400-2480 MHz) from fixed and mobile devices. However, embodiments of the invention contemplate that the respirator **10** can include additional or alternative wireless communication circuits based on other standards or protocols to communicate with other devices. The respirator **10** can also be configured without wireless communication capability.

The power button **30b** can reside over a power core **30** that holds at least part of an operational circuit **100** that includes a flex circuit or a printed circuit board **100c** (FIG. 8). The circuit **100** can monitor for low power and include an audible alarm that sounds upon power initiation and low battery power. The button **30b** can include an LED indicator light **31** that is on when the respirator is on. To adjust a wireless communication (e.g., Bluetooth) volume, a user can rotate the activation button **30b**. The circuit **100** can include a motor, LED, alarms, digital signal processor, power switch and the like.

The respirator **10** also includes a cooling source **60**, such as a powered-pressurized air source, typically a fan **60**, residing centrally in the front or shield portion of the collar **15f** so as to be proximate a mouth of a user. Below the fan **60**, the device can include an exhaust valve **62** in fluid communication with an exit port **15e** (FIG. 8) that vents a user's breath. The fan **60** can be a low decibel operating fan of about 35.4 dbA. However, lower or higher decibel fans can be used (with baffles or sound insulation as appropriate). The fan **60** can be a small fan. The fan **60** can have dimensions of 40 mm×40 mm×10 mm or 40×20 mm and may be a laptop fan. An example of a fan **60** is a DC axial fan, 5V 40×20 TAC OUT.

The fan **60** can be configured to move air at a rate of at least about 5 cf/m (cubic feet/minute), typically at least 8 cf/m, and more typically between about 8-12 cf/m such as about 8.8 cf/m, about 9 cf/m, about 10 cf/m. The fan can operate on any suitable voltage including between about 5V-12V. The fan **60** can have a use life of 16 hours using on-board rechargeable batteries **70**. The respirator **10** can allow a user to adjust the fan speed/air flow or the respirator can self-adjusted based on an electronically monitored temperature inside or outside the head gear.

The respirator **10** can have a battery pack **70** that includes a plurality of battery cells or batteries that provide sufficient power, typically at least about 1000 mA/h, typically about 2000 mA/h. The battery pack **70** can be held in a battery chamber **71** (FIG. 2) on the back of the back segment of the chin collar **15**. However, the battery pack **70** can be distributed or held in another location. The battery pack **70** can include a plurality of 3.2V LiFePO₄ rechargeable cells. These batteries contain no heavy metals, and are smaller and lighter weight than traditional NiCa or Lithium Ion batteries. However, other batteries can be used, rechargeable or not.

Different batteries can be used to power different components or a single battery supply can power all on-board components.

FIG. 5 illustrates that the front of the face shield at the chin collar **15f** can include a filter chamber **18c** that slidably receives filter cartridges **19**. The filter **19** can have a flexible plastic perimeter rim to inhibit solid waste (most of the filter can be biodegradable). While it is shown as including a single filter chamber **18c**, on one side of the front portion of the chin collar, multiple filters may be used at any suitable location or locations or the single filter can be provided at a different location.

FIG. 8 illustrates that air is pulled in through air inlets **18i** into filter **19**, then internal air flow **25f** is directed through ducting **22ch** around the perimeter of the shield **20** to exit through air flow ports **22** at the top of the shield **20**. Exhaled air **25e** can be directed down and away from the face of a user, out from the mask **20** using an exhalation valve **62**, such as a COOL FLOW™ exhalation valve from 3M Corporation.

To promote hygiene or inhibit multiple users from sharing a respirator **10**, the device **10** can include a password, biometric recognition input, physical lock and key arrangement or other lock that inhibits activation by an unauthorized user.

FIG. 9 illustrates a storage unit **200** for the respirator **10**. The storage units can be individually sized to hold single ones of the respirators **10** or a plurality of the respirators **10**. The storage units **200** can include a base **201** that includes a recharging circuit **202** for the rechargeable batteries **70**. The storage units **200** can be configured as a wall-mounted storage unit. For example, a station of storage units (or one storage unit that holds multiple respirators) can be mounted to a wall of a poultry computer control room for ease of access and storage. The storage unit can include an acrylic or other material cover **202**. The base **201** can be configured with a wireless recharging circuit **205** that recharges the batteries. FIG. 10 illustrates that the base **201** can include exposed terminals **205t** that connect with terminals on the respirator for charging the on-board batteries **70**. However, a charging cord may also be used to provide the connection for charging the respirator **10**. The storage unit **200** can provide a sealed protective box/container with a hanger that may preserve or prolong the life of the filter **19** and/or inhibit the respirator from contamination or dirt exposure during periods of non-use. The respirator **10** can be locked to the base or the sealed cover can be locked to inhibit unauthorized use.

The respirator **10** can include a compliance monitoring module that monitors the dates of activation/use. This module can be partially or totally "on-board" the respirator or can reside partially or totally in a control or monitoring station. The control station can be in wireless communication with a plurality of respirators to monitor for dates/times of activation and the monitoring module can send an alert when it is determined that a user is not in compliance with defined norms, e.g., at least 4 hours of each workday or when the respirator is not activated for at least a certain number of hours over a work week. The monitoring can be triggered based on when a worker "clocks in" or otherwise correlated to a work schedule. On-board sensors can be used to monitor if the respirator **10** is actually used versus just "turned on" and set aside, including moisture or temperature monitors, air flow (particularly for exhaust air flow, such as through an exhaust valve). The circuit **100** can include a clock, timer and/or other monitoring input accessible by a remote processor. In some embodiments, the monitoring can be based on data from the storage unit, e.g., when it is in the storage unit when a worker is onsite. Thus embodiments of the invention propose methods of monitoring for compliance with safety standards.

The foregoing is illustrative of the present invention and is not to be construed as limiting thereof. Although a few exemplary embodiments of this invention have been described, those skilled in the art will readily appreciate that many modifications are possible in the exemplary embodiments without materially departing from the novel teachings and advantages of this invention. Accordingly, all such modifications are intended to be included within the scope of this invention as defined in the claims. In the claims, means-plus-function clauses, where used, are intended to cover the structures described herein as performing the recited function and not only structural equivalents but also equivalent structures. Therefore, it is to be understood that the foregoing is illustrative of the present invention and is not to be construed as limited to the specific embodiments disclosed, and that modifications to the disclosed embodiments, as well as other embodiments, are intended to be included within the scope of the appended claims. The invention is defined by the following claims, with equivalents of the claims to be included therein.

That which is claimed is:

1. A portable personal respiratory protection device, comprising:

a self-contained head gear member comprising a chin collar that has a front segment that defines a mouth portion and attaches to a back segment that is adapted to reside over ears of a user and extend about a lower back segment of a head of the user, wherein the back segment of the chin collar comprises a first locking member that is sized and configured to releasably engage a second cooperating locking member on the front segment of the chin collar for locking engagement and/or size adjustment of the chin collar;

a visually transmissive face mask extending upwardly from the front segment of the chin collar that, in position, is adapted to sealably engage a face of the user, the face mask having an outer perimeter with two opposing side portions and an uppermost portion extending between the two side portions, wherein the head gear member has an open upper portion residing between the uppermost portion of the face mask and the back segment of the chin collar that, when worn, is adapted to expose a top and upper rear portion of a head of the user to environmental conditions;

a filter chamber in the chin collar configured to releasably receive a filter for air intake; and

a plurality of air flow ports residing across the upper portion of the perimeter of the face mask to direct cooling air into the face mask.

2. The device of claim 1, wherein the face mask outer perimeter comprises a curvilinear frame that rises from opposing sides of the front segment of the chin collar and defines the uppermost portion of the face mask to terminate above a brow line and across a forehead of the user.

3. The device of claim 2, further comprising an inner sealant material attached to the frame and the front segment of the chin collar, wherein the air flow ports are defined in an upper portion of the inner sealant material.

4. The device of claim 1, further comprising a fan held in the front segment of the chin collar in fluid communication with the air flow ports, a wireless communication circuit held

in the chin collar, and a power source held in the chin collar, the power source configured to power the fan and wireless communication circuit.

5. The device of claim 4, wherein the wireless communication circuit comprises a short wavelength radio transmission circuit.

6. The device of claim 1, wherein the chin collar releasably holds the filter on one side of the front segment of the chin collar, and wherein the second locking member is on an opposing side of the front segment of the chin collar.

7. The device of claim 1, wherein the front segment of the chin collar has a width sufficient so that a lowermost portion is adapted to reside above a neck of the user proximate a chin of the user and an uppermost portion is adapted to terminate proximate but under a nose of the user, and wherein the visually transmissive face mask defines a wide field of view, and wherein the back segment of the chin collar has a substantially constant width of between about 1.5-3.5 inches.

8. The device of claim 1, wherein the back segment of the chin collar comprises a padding layer that extends inside an outer shell of the back segment and has a width sufficient to cover a respective ear of a user, and wherein the padding is releasably engaged to the back segment of the chin collar for cleaning or replacement.

9. The device of claim 1, wherein the first locking member is a ratcheting buckle and the second cooperating locking member is a receiving shaft, wherein the device further includes a quick release button to allow the buckle to be easily disengaged by a user.

10. The device of claim 1, further comprising a power on/off member with an adjustable volume control residing on the back segment of the chin collar proximate an ear of the user.

11. The device of claim 1, wherein the back segment comprises an outer shell that resides over an inner padding layer and right and left ear portions, and wherein the back segment outer shell comprises a plurality of apertures residing proximate each ear portion of the back segment to thereby allow for increased sound penetration.

12. The device of claim 1, further comprising a fan residing in a front medial portion of the front segment of the chin collar, wherein the fan is configured to generate air flow in the device of between about 6-10 cubic feet/minute.

13. The device of claim 12, further comprising a battery chamber in the back segment of the chin collar for powering the fan.

14. The device of claim 1, further comprising an external power activation member residing in the back segment of the chin collar over an internal circuit board and a wireless communication activation member residing in the front segment of the chin collar.

15. The device of claim 1, in combination with a storage unit comprising a battery charging circuit.

16. The device of claim 15, wherein the storage unit is a wall-mount unit having a base that holds the personal respiratory protection device and recharges batteries in the back segment of the chin collar when held thereon.

17. The device of claim 15, wherein the storage unit further comprises a visually transmissive lid that closes against a base to enclose at least one personal respiratory protection device therein.