

Abstract
“How A Vessel of This Magnitude Was Moved”:
A Comparative Analysis of Confederate Ironclad Steam Engines, Boilers, and Propulsion
Systems
by Saxon T. Bisbee
November 2012
Director: Dr. Bradley A. Rodgers
Department of History

The development of steam propulsion machinery in warships during the 19th century in conjunction with iron armor and shell guns resulted in a technological revolution in the world's navies. Warships utilizing all of these technologies had been built in France and Great Britain dating back to the 1850s, but it was during the American Civil War that ironclads powered solely by steam proved themselves in large numbers. The armored warships built by the Confederate States of America especially represented a style adapted to scarce industrial resources and facilities. The development and / or procurement of propulsion machinery for these warships have received only peripheral study.

Through historical and archaeological investigation, this thesis consolidates and expands on the scattered existing information on Confederate ironclad steam engines, boilers, and propulsion systems. Using a comparative analytical approach, the steam plants of 27 ironclads are assessed by source, type, and performance, among other factors. This has resulted in an analysis of steam machinery development during the Civil War and also adds to the relatively small knowledge base relating to Confederate ironclads.

“How A Vessel of This Magnitude Was Moved”:
A Comparative Analysis of Confederate Ironclad Steam Engines, Boilers, and Propulsion
Systems

A Master of Arts Thesis
Presented To
The Faculty of the Department of History
East Carolina University

In Partial Fulfillment
of the Requirements for the Degree
Master of Arts

by
Saxon T. Bisbee
November 2012

©Copyright 2012
Saxon T. Bisbee

“How A Vessel of This Magnitude Was Moved”:

A Comparative Analysis of Confederate Ironclad Steam Engines, Boilers, and Propulsion
Systems

by

Saxon T. Bisbee

APPROVED BY:

THESIS DIRECTOR: _____
Bradley Rodgers, PhD

COMMITTEE MEMBER: _____
Nathan Richards, PhD

COMMITTEE MEMBER: _____
Wade Dudley, PhD

COMMITTEE MEMBER: _____
William Still Jr., PhD

CHAIR OF THE DEPARTMENT OF HISTORY:

Gerald Prokopowicz, PhD

DEAN OF THE GRADUATE SCHOOL:

Paul J. Gemperline, PhD

ACKNOWLEDGEMENTS

No research project of this scale can be done alone. Pondering and researching for years is one thing; actually writing satisfactorily is quite another. I have many wonderful people to thank for helping me in this regard. I hope I have not forgotten anybody, and ask forgiveness if I have. First and foremost, I thank my thesis advisor, Dr. Brad Rodgers, for his patience and in helping greatly to make my work more readable; and my other committee members: Drs. Nathan Richards, Wade Dudley, and Bill Still. All are experts in their fields, and I feel especially privileged to have had on my committee such an expert on the Confederate Navy as Dr. Still.

In presenting the facts, I owe much to Bob Holcombe, who next to Dr. Still is probably the world's leading expert on Confederate ironclads. There is a great amount of material in this thesis that he kindly provided me, and I would have been much less comprehensive and sure of myself without his knowledge. I also wish to thank the staff of the Port Columbus Civil War Naval Museum, especially Bruce Smith, Ken Johnston, Jeff Seymour, and Jerry Franklin. Their hospitality and dedication made my research and stay in Georgia very enjoyable.

Others who helped me greatly are David Rousar, who kindly allowed me to use never-before-seen scans of original machinery plans he owns, and the staffs of the National Archives (College Park / Washington, DC); the Emory University Manuscript, Archives, and Rare Book Library; the UNC Chapel Hill Southern Historical Collection; the University of Alabama Special Collections; the Alabama Department of Archives and History; East Carolina University's Joyner Library; the North Carolina Underwater Archaeology Branch; and The Mariners' Museum Library.

I must thank my family and friends for being there and believing in me. A final "thank you" is also due to Dr. Fred Hocker, who ultimately convinced me to pursue this difficult topic.

TABLE OF CONTENTS

LIST OF FIGURES.....	vi
CHAPTER 1	
INTRODUCTION.....	1
Formation of the Confederate States Navy.....	5
The Confederate Ironclad Program.....	11
Confederate Ironclad Hull Types.....	18
Marine Steam Engine Operations in the Mid-19th Century.....	23
CHAPTER 2	
THE DEVELOPMENT OF STEAM-DRIVEN ARMORED VESSELS.....	31
The First Steam-Powered Warships.....	33
The Screw-Propelled Warship.....	39
The Iron-Hulled Steam Warship.....	47
The Armor-Plated Steam Warship.....	51
CHAPTER 3	
STEAM MACHINERY TYPES IN AMERICA, 1800-1860.....	59
Engines for Paddlewheel Propulsion.....	61
Engines for Screw Propulsion.....	76
Boilers.....	85
Conclusions.....	92
CHAPTER 4	
MANUFACTURERS AND OTHER SOURCES.....	94
Tredegar Iron Works.....	95
Columbus Naval Iron Works.....	100
Shockoe Foundry / Confederate Naval Works.....	105

Charlotte Navy Yard.....	107
New Orleans Manufacturers.....	109
Other Sources.....	113
Northern-Built.....	124
Conclusions.....	133
CHAPTER 5	
IRONCLAD ENGINES IN PRACTICE—FIRSTHAND ACCOUNTS.....	135
Regarding CSS <i>Manassas</i>	135
Regarding CSS <i>Virginia</i>	138
Regarding CSS <i>Baltic</i>	145
Regarding CSS <i>Louisiana</i>	146
Regarding CSS <i>Arkansas</i>	149
Regarding CSS <i>Richmond</i>	158
Regarding CSS <i>Chicora</i> and <i>Palmetto State</i>	159
Regarding CSS <i>North Carolina</i>	162
Regarding CSS <i>Savannah</i>	164
Regarding CSS <i>Virginia II</i>	168
Regarding CSS <i>Columbia</i>	170
Regarding CSS <i>Missouri</i>	171
Conclusions.....	175
CHAPTER 6	
ENGINEERING SPECIFICATIONS OF 27 CONFEDERATE IRONCLADS.....	176
CSS <i>Manassas</i> (ex- <i>Enoch Train</i>).....	177
CSS <i>Virginia</i> (ex-USS <i>Merrimack</i>).....	179

CSS <i>Baltic</i>	184
CSS <i>Arkansas</i>	187
CSS <i>Louisiana</i>	188
CSS <i>Georgia</i>	190
CSS <i>Richmond</i>	194
CSS <i>Chicora</i>	197
CSS <i>Palmetto State</i>	199
CSS <i>North Carolina</i>	201
CSS <i>Raleigh</i>	202
CSS <i>Savannah</i>	205
CSS <i>Tennessee</i>	208
CSS <i>Columbia</i>	210
CSS <i>Charleston</i>	212
CSS <i>Virginia II</i>	215
CSS <i>Nashville</i>	217
CSS <i>Tuscaloosa</i>	220
CSS <i>Huntsville</i>	222
CSS <i>Albemarle</i>	222
CSS <i>Neuse</i>	226
CSS <i>Fredericksburg</i>	229
CSS <i>Missouri</i>	231
CSS <i>Mississippi</i>	236
CSS <i>Jackson</i>	238

<i>CSS Milledgeville</i>	247
<i>CSS Wilmington</i>	249
Conclusions.....	253
CHAPTER 7	
CONCLUSIONS.....	254
APPENDIX A	
CONFEDERATE IRONCLAD STEAM MACHINERY SPECIFICATIONS.....	260
APPENDIX B	
AUXILIARY EQUIPMENT.....	271
REFERENCES.....	279

LIST OF FIGURES

FIGURE I.1.	Confederate Secretary of the Navy Stephen R. Mallory.....	6
FIGURE I.2.	Confederate President Jefferson Davis.....	9
FIGURE I.3.	Confederate ordnance expert John M. Brooke.....	13
FIGURE I.4.	Confederate Chief Naval Constructor John L. Porter.....	14
FIGURE I.5.	Porter’s 1846 Pittsburgh ironclad design.....	15
FIGURE I.6.	USS <i>Merrimack</i> at Southampton.....	15
FIGURE I.7.	Brooke’s 1861 ironclad design.....	16
FIGURE I.8.	Porter’s 1861 ironclad design.....	16
FIGURE I.9.	<i>Richmond</i> -class ironclad midsection.....	20
FIGURE I.10.	Bow profiles of CSS <i>Tennessee</i> and <i>Columbia</i>	20
FIGURE I.11.	CSS <i>Virginia II</i> midsection.....	21
FIGURE I.12.	CSS <i>Albemarle</i> midsection.....	22
FIGURE I.13.	CSS <i>Milledgeville</i> midsection.....	23
FIGURE I.14.	CSS <i>Wilmington</i> sheer, body, and plan views.....	23
FIGURE I.15.	Starting a steam engine.....	26
FIGURE I.16.	Riverboat engine levers and wipers.....	27
FIGURE I.17.	Stephenson valve gear.....	28
FIGURE I.18.	Engineering officer appearance.....	30
FIGURE II.1.	Boulton and Watt pump engine.....	32
FIGURE II.2.	Fulton’s Steam Battery (<i>Demologos</i>) plans.....	34
FIGURE II.3.	HMS <i>Congo</i> 20-horsepower beam engine.....	36
FIGURE II.4.	HMS <i>Terrible</i>	38
FIGURE II.5.	USS <i>Mississippi</i>	39
FIGURE II.6.	Smith’s screw propeller on <i>Archimedes</i>	41
FIGURE II.7.	Erickson’s screw propeller on <i>Robert F. Stockton</i>	41
FIGURE II.8.	Screw sloop <i>Archimedes</i>	42
FIGURE II.9.	HMS <i>Rattler</i> versus HMS <i>Alecto</i>	43
FIGURE II.10.	French battleship <i>Napoléon</i>	44
FIGURE II.11.	Cross-section of USS <i>Merrimack</i>	46
FIGURE II.12.	SS <i>Great Britain</i>	48
FIGURE II.13.	Iron-hulled warship <i>Nemesis</i>	49
FIGURE II.14.	USS <i>Michigan</i>	51
FIGURE II.15.	French ironclad floating battery <i>Dévastation</i>	53
FIGURE II.16.	British ironclad floating battery HMS <i>Terror</i>	54
FIGURE II.17.	<i>La Gloire</i>	55
FIGURE II.18.	Longitudinal cutaway of <i>Gloire</i>	55
FIGURE II.19.	HMS <i>Warrior</i>	56
FIGURE II.20.	Section through <i>Warrior</i> ’s engine room.....	57
FIGURE III.1.	Typical crosshead engine.....	63
FIGURE III.2.	Typical walking beam engine.....	64
FIGURE III.3.	USRC <i>Louis McLane</i>	65
FIGURE III.4.	Typical side-lever engine.....	66
FIGURE III.5.	Model of HMS <i>Devastation</i> ’s Siamese engines.....	68
FIGURE III.6.	Typical Gorgon engine.....	68

FIGURE III.7.	Typical grasshopper engine.....	69
FIGURE III.8.	Typical oscillating engines.....	70
FIGURE III.9.	Typical vertical inverted direct-acting engine.....	72
FIGURE III.10.	Typical steeple engine.....	73
FIGURE III.11.	Typical return connecting rod engine.....	74
FIGURE III.12.	Typical Western river steamboat engine.....	75
FIGURE III.13.	Vertical inverted direct-acting tugboat engine.....	79
FIGURE III.14.	CSS <i>Chattahoochee</i> 's horizontal direct-acting engines.....	81
FIGURE III.15.	Typical trunk engine.....	82
FIGURE III.16.	USS <i>Monadnock</i> 's Erickson vibrating lever engine.....	83
FIGURE III.17.	HMS <i>Constance</i> 's inclined inverted direct-acting engines.....	84
FIGURE III.18.	HMS <i>Comet</i> 's rectangular flue boiler.....	87
FIGURE III.19.	Low pressure "Scotch" marine horizontal firetube boiler.....	88
FIGURE III.20.	CSS <i>Virginia</i> 's Martin vertical watertube boiler.....	89
FIGURE III.21.	Typical return flue boiler layout of Western river steamboats.....	90
FIGURE III.22.	Typical locomotive or firebox boiler.....	91
FIGURE IV.1.	Tredegar Iron Works.....	96
FIGURE IV.2.	Columbus Iron Works.....	103
FIGURE IV.3.	City-class Union ironclad gunboats under construction.....	114
FIGURE IV.4.	Construction of CSS <i>Arkansas</i>	117
FIGURE IV.5.	J.M. Eason & Brother advertisement.....	122
FIGURE IV.6.	Baltimore & Ohio locomotive #37.....	123
FIGURE IV.7.	Loring's City Point Works advertisement.....	125
FIGURE IV.8.	West Point Foundry.....	127
FIGURE IV.9.	USS <i>Arctic</i>	129
FIGURE IV.10.	Reaney, Neafie & Co.'s Penn Works advertisement.....	130
FIGURE IV.11.	CSS <i>Lady Davis</i>	131
FIGURE V.1.	Final moments of CSS <i>Manassas</i>	137
FIGURE V.2.	Burning of USS <i>Merrimack</i> and Gosport Navy Yard.....	139
FIGURE V.3.	USS <i>Monitor</i> versus CSS <i>Virginia</i>	144
FIGURE V.4.	CSS <i>Louisiana</i> towed to Fort St. Philip.....	148
FIGURE V.5.	CSS <i>Arkansas</i> above Vicksburg.....	152
FIGURE V.6.	Battle of Trent's Reach.....	160
FIGURE V.7.	CSS <i>Chicora</i> and <i>Palmetto State</i> attack the blockade.....	162
FIGURE V.8.	Destruction of CSS <i>Savannah</i>	168
FIGURE VI.1.	Sketch of CSS <i>Manassas</i>	178
FIGURE VI.2.	Martin vertical watertube boiler.....	182
FIGURE VI.3.	Plan of CSS <i>Virginia</i> 's return connecting rod engines.....	183
FIGURE VI.4.	Top view of <i>Virginia</i> 's engines.....	183
FIGURE VI.5.	End view of <i>Virginia</i> 's engines.....	184
FIGURE VI.6.	Porter's plans of <i>Virginia</i>	184
FIGURE VI.7.	CSS <i>Baltic</i>	186
FIGURE VI.8.	Sketch of CSS <i>Arkansas</i>	188
FIGURE VI.9.	Sketch of plan of CSS <i>Louisiana</i>	189
FIGURE VI.10.	Probable photograph of CSS <i>Georgia</i>	191
FIGURE VI.11.	Archaeological reconstruction of <i>Georgia</i> 's engines.....	193

FIGURE VI.12.	Archaeological reconstruction of condenser.....	193
FIGURE VI.13.	Typical horizontal marine firetube boiler.....	193
FIGURE VI.14.	Archaeological reconstruction of <i>Georgia</i> 's propeller layout.....	194
FIGURE VI.15.	Plans of <i>Richmond</i> -class ironclad.....	195
FIGURE VI.16.	Low pressure "Scotch" marine horizontal firetube boiler.....	196
FIGURE VI.17.	CSS <i>Chicora</i>	197
FIGURE VI.18.	Sketch of tugboat <i>Aid</i> boiler and reversing gear.....	198
FIGURE VI.19.	Mid-19th century single-cylinder tugboat engine.....	199
FIGURE VI.20.	CSS <i>Palmetto State</i>	200
FIGURE VI.21.	Sketch of tugboat <i>James Gray</i> machinery layout.....	200
FIGURE VI.22.	Sketch of tugboat <i>James Gray</i> boiler.....	201
FIGURE VI.23.	CSS <i>North Carolina</i> wreck site plan.....	203
FIGURE VI.24.	CSS <i>Raleigh</i> wreck site midsection.....	204
FIGURE VI.25.	Inboard profile of CSS <i>Savannah</i>	206
FIGURE VI.26.	Engine room cross-section of <i>Savannah</i>	207
FIGURE VI.27.	USS (ex-CSS) <i>Tennessee</i>	208
FIGURE VI.28.	Plans of <i>Tennessee</i> 's propulsion system.....	209
FIGURE VI.29.	Lines of CSS <i>Columbia</i>	210
FIGURE VI.30.	<i>Columbia</i> 's original twin-screw configuration.....	211
FIGURE VI.31.	Inboard profile of <i>Columbia</i>	212
FIGURE VI.32.	Plans of CSS <i>Charleston</i>	214
FIGURE VI.33.	Plans of CSS <i>Virginia II</i>	216
FIGURE VI.34.	CSS <i>Nashville</i>	218
FIGURE VI.35.	Plans of "Gunboat No. 1".....	220
FIGURE VI.36.	<i>Albemarle</i> sunk at Plymouth, North Carolina.....	223
FIGURE VI.37.	<i>Albemarle</i> after salvage.....	224
FIGURE VI.38.	<i>Albemarle</i> bow after salvage.....	224
FIGURE VI.39.	Plans of CSS <i>Albemarle</i>	225
FIGURE VI.40.	Sketches of CSS <i>Neuse</i>	227
FIGURE VI.41.	Excavation of <i>Neuse</i>	228
FIGURE VI.42.	Exposed hull section of <i>Neuse</i>	228
FIGURE VI.43.	<i>Neuse</i> on display before 2012 removal to new facility.....	229
FIGURE VI.44.	Plans of CSS <i>Fredericksburg</i>	230
FIGURE VI.45.	USS <i>Cairo</i>	232
FIGURE VI.46.	Porter's plans of light draft centerwheel ironclad.....	234
FIGURE VI.47.	<i>Cairo</i> 's port engine, pitman arm, and paddlewheel.....	235
FIGURE VI.48.	Engineering drawing of <i>Cairo</i> 's engines.....	235
FIGURE VI.49.	Engineering drawing of <i>Cairo</i> 's boilers.....	236
FIGURE VI.50.	Sketch of CSS <i>Mississippi</i> 's cross-sectional shape.....	237
FIGURE VI.51.	Sketch of <i>Mississippi</i> 's general machinery layout.....	237
FIGURE VI.52.	<i>Mississippi</i> as completed.....	238
FIGURE VI.53.	CSS <i>Jackson</i> 's original and modified designs.....	239
FIGURE VI.54.	<i>Jackson</i> after launching.....	240
FIGURE VI.55.	Plans of "Muscogee's Engines".....	241
FIGURE VI.56.	Plans of unidentified pitman arm, crank, and cams.....	241
FIGURE VI.57.	<i>Jackson</i> 's engine mounting timbers.....	242

FIGURE VI.58.	Remains of shafting to propellers on <i>Jackson</i>	242
FIGURE VI.59.	Starboard engine of CSS <i>Chattahoochee</i>	243
FIGURE VI.60.	<i>Chattahoochee</i> engine front view.....	243
FIGURE VI.61.	<i>Chattahoochee</i> engine top view.....	244
FIGURE VI.62.	Cylinder head of <i>Chattahoochee</i> engine.....	244
FIGURE VI.63.	Cylinder head of <i>Chattahoochee</i> engine side view.....	245
FIGURE VI.64.	<i>Chattahoochee</i> 's engine mounting timbers.....	245
FIGURE VI.65.	Thrust bearing mounting block for <i>Chattahoochee</i> or <i>Jackson</i>	246
FIGURE VI.66.	Parts of reversing gear for <i>Chattahoochee</i> or <i>Jackson</i>	246
FIGURE VI.67.	More parts of reversing gear for <i>Chattahoochee</i> or <i>Jackson</i>	247
FIGURE VI.68.	Plans of CSS <i>Milledgeville</i>	248
FIGURE VI.69.	Plans of "Engine No. 15".....	250
FIGURE VI.70.	Plans of CSS <i>Wilmington</i>	252
FIGURE B.1.	Closed and jet condensers.....	272
FIGURE B.2.	"Donkey" boiler.....	273
FIGURE B.3.	Steam capstan with engine.....	274
FIGURE B.4.	Typical main force pump.....	275
FIGURE B.5.	Worthington simplex and duplex pumps.....	275
FIGURE B.6.	Typical doctor engine.....	276
FIGURE B.7.	Typical closed feedwater heater.....	277
FIGURE B.8.	Typical live steam injector.....	278
FIGURE B.9.	Typical gauge cocks, safety valve, and hydrostatic lubricator.....	278

CHAPTER 1: INTRODUCTION

Looking back from a 21st century vantage point, it can readily be seen that virtually all of modern technological society has its origins in the 19th century or earlier. The 19th century saw rapid and revolutionary changes in the way people lived, worked, and waged war. Some of the greatest effects of the technological advances of the 1800s were seen in the world's navies, and from these changes emerged the concept of modern naval engineering and practice. Wooden, sail-driven men-of-war had seemingly remained little changed for centuries, yet in the mid-19th century these vessels were made obsolete, giving way to vessels armored with iron and steel, equipped with rifled guns, and powered wholly by steam. These powerful weapons were termed "ironclads."

The acceptance and spread of the armored screw-propelled warship represented a truly revolutionary change in warfare at sea, and many remarked upon it. James P. Baxter III (1933:3), writing on the introduction of such vessels, perhaps states this change most effectively in relation to this work's focus:

The Elizabethan seadogs who circled the globe with Drake might have felt at home in the sailing sloop of war *Cumberland*, as she sank with colors flying on the 8th of March, 1862. Of the five great naval revolutions of the nineteenth century—steam, shell guns, the screw propeller, rifled ordnance, and armor—one only had influenced her design or equipment. Nothing but her heavy battery of 9-inch smooth-bore shell guns would have seemed wholly unfamiliar to the conquerors of the Spanish Armada.

The vessel responsible for *Cumberland's* demise, CSS *Virginia*, was an ironclad, a product of industrialization in Great Britain, France, Russia, and the United States.

The engagement Baxter refers to has become one of the most famous naval battles in world history, and took place in its entirety from 8-9 March, 1862. It was fought in two parts, the first of which (on 8 March) resulted in the figurative "death of the wooden warship," while the battle on 9 March was the first ever fought between armored steam-driven warships. The two

primary participants in these battles were the aforementioned CSS *Virginia*, more often remembered by its previous name *Merrimack*, and the USS *Monitor*. Although the former had once itself been a wooden warship, it was converted to an ironclad and proved the superiority of ironclads against wooden vessels, while *Monitor* in turn rendered *Virginia* obsolete by the use of a revolving turret. The conflict in which these two vessels proved the worth of the burgeoning “new navy” became known as the Battle of Hampton Roads and took place near the height of the American Civil War.

The Civil War has been one of the most scrutinized conflicts in American and world history. This conflict, which lasted from 1861 to 1865, saw four long years of bloody fighting between Northerners and Southerners. The great land campaigns carried out by Lee, Sherman, and Grant have been very well covered in academic studies (such as Barrett 1956, Connelly 1978, and Fuller 1991), but technological development during what is often considered the first “modern” war has not been examined as extensively. As with all large conflicts, the Civil War became “...a testing ground for new developments in military technology, including ironclads” (Still 1985:5). Armored vessels marked the peak of technological development during the conflict and indeed became one of the Civil War’s most famous aspects. This thesis offers a comparative analysis and description of the steam machinery used for propelling Confederate ironclad vessels.

Development of effective steam propulsion technology was one of the greatest factors in the realization of ironclad warships during the 1850s and 1860s. Unfortunately, serious studies concentrating on the marine propulsion machinery of the Civil War era are quite rare. Although the South was often quite creative in building and obtaining power plants for these vessels, the

Confederate ironclads, especially those improved mid- and late-war models built with experience gained from *Virginia's* deployment, have garnered little attention regarding machinery.

Not widely appreciated is the fact that technical data for many Confederate ironclads still exists, albeit in scattered locations. Examination of Southern ironclad propulsion systems offers not only new data on these fascinating ships, but also offers a broader picture of how marine steam machinery was manufactured, obtained, and dispersed to the appropriate vessels throughout the Confederacy. This study, therefore, attempts to consolidate as much of this information as possible into one source comparing machinery types used in Confederate ironclads. In doing this, it builds especially on *Iron Afloat: The Story of the Confederate Armorclads* (Still 1985) and “The Evolution of Confederate Ironclad Design” (Holcombe 1993).

Although the Confederate States of America ultimately began construction on some 50 ironclads of varying types, only 25 saw any sort of active service. Among this number were two foreign-built: *Atlanta*, formerly the Scottish iron-hulled blockade runner *Fingal*, and *Stonewall*, a French-built ironclad corvette. These two vessels are not considered in this study because of the great technological differences between them and the American-built ironclads. *Fingal's* machinery in particular marked the best of British engineering practice in the 1860s, and can be considered as at least a generation ahead of American technology, making comparison nearly useless. Following in this vein is the Confederate-built *Texas*, which was provided with British engines taken from a wrecked blockade runner. Another important ironclad vessel that is not discussed is USS *Eastport*, a sidewheel river gunboat begun by the Confederates but captured and completed for Union service. (Still 1985:227-228; Holcombe 1993:26-30,89)

In all, this study contains a sample size of 27 vessels—those completed and nearly completed, having received at least a portion of their machinery prior to destruction. There were

probably more than this number in reality, but a lack of records prevents any certainty. For instance, while the mighty CSS *Mississippi* is well-covered, the “Bigbee boats,” three or four ironclads building on the Tombigbee River of Alabama which were quite advanced at the time of their destruction, are not. Such is the case with most of the unfinished ironclads—only small hints and uncertainties. Therefore, although there are many interesting possibilities for future research regarding both the foreign-built and unfinished ironclads, this thesis concentrates only on the finished products, as well as some few of those nearly finished, namely: *Mississippi*, *Jackson* (often called *Muscogee*), *Milledgeville*, and *Wilmington*. (Confederate States of America [CSA] 1863:108-117,121-136; Still 1985:212; Holcombe 1993:95-96,109-112,123-130)

This study of Confederate ironclad propulsion systems is divided into seven chapters, each focused on an important facet of the topic. Chapter I is simply an introduction, but also offers a brief account of the Confederate States Navy’s formation, Confederate Naval Secretary Mallory’s ironclad program, ironclad hull types, and basic operation of 1860s marine steam engines. Chapter II presents a general history of the development of steam-powered armored warships, and Chapter III follows with an explanation and overview of marine steam machinery types commonly used in the United States by 1860. An important aspect in any study of machinery is the manufacturing source, and Chapter IV, therefore, presents as complete a picture as possible regarding the varied sources of Confederate ironclad machinery. Chapter V offers an important and interesting series of firsthand accounts regarding the use of the ironclads’ steam engines in actual service, and Chapter VI finishes with a detailed discussion of each ironclad’s propulsion machinery. Finally, Chapter VII presents conclusions arrived at during the course of this study. In addition, two appendices follow the text; the first presents all relevant machinery

data on the 27 ironclads discussed in tabulated form, while the second offers a discussion of auxiliary systems onboard the ironclads, such as pumps and “doctor” engines.

Therefore, this thesis presents a complete list of the machinery types installed in Confederate ironclads, as well as an analysis of machinery manufacturers and the qualitative theory versus actual performance of these propulsion systems. It delves into trends in technological development during the 1860s, epitomized by the steam-driven vessel of war. Finally, many stand to benefit from this research: those interested in naval architecture and engineering, scholars of the 19th century and the American Civil War (especially those interested in maritime matters), those interested in naval history, and finally the general reader interested in such topics.

Formation of the Confederate States Navy

The beginnings of the Confederate States Navy lay largely in the separate policies of the seceding states. When the Civil War began, several vessels had been seized for military service, but the Southern naval forces of 1861 were a far cry from those that allowed the completion of *CSS Virginia* one year later. Indeed, by and large the Confederate Navy ultimately pushed the boundaries of ingenuity and changed the character of war at sea. All of this is made more impressive “If one remembers that to reach its ends the Confederate navy had to start literally from zero...” (Luraghi 1996:346), for its first few small and widely scattered vessels were weak and unfit. The fledgling navy needed the guiding hand of an able administrator, and it soon received one.

The extraordinary resistance shown against the overwhelming Union Navy and the skilled development of the ironclad, commerce raiding, and mine warfare programs were mostly due to one extraordinary man: Stephen Russell Mallory (Figure I.1). This man served for the

entire Civil War period as Confederate Secretary of the Navy, and had built it into a modern and effective military service by 1865.



FIGURE I.1. Stephen Russell Mallory, Confederate Secretary of the Navy (Still 1997:21; courtesy of Naval Historical Division)

For most of the war the Southern navy and its chief administrator, despite their successes, and also being the only Confederate institution to never formally surrender, were looked upon with derision by the predominantly agrarian public. Much like today, the news media of the Confederacy made the most of negative events. Even with his successes, there was little Secretary Mallory could do against the technological and numerical superiority of the Union Navy after his programs became widely known. In retrospect, it appears that he did everything possible with what he had, and achieved notable successes against long odds. In order to fully appreciate Mallory's ironclad program, his first major challenge, actually organizing a navy, must be looked at in detail. (Luraghi 1997:345-349; Still 1997:38-39)

In his biography of the Confederate navy chief, Joseph T. Durkin (1954:11) wrote: “There is some doubt as to the year of Stephen Mallory’s birth. It was certainly 1810 or 1811 [more recent research, presented in Still 1997:4, suggests it was actually 1812]”. While little is known about the future Secretary’s early life, by the age of nine he was living on Key West, and spent his entire youth and early adulthood there. Mallory became quite familiar with the sea and ships even while practicing as a Florida lawyer, and his intelligence and reputation paved the way to a U.S. Senate seat in 1851. In 1853, he began his first major appointment, that of chairman of the Senate Naval Affairs Committee, “. . . a post which foreshadowed his future duties during the Civil War” (Durkin 1954:61). The Florida senator had always been interested in ships and naval affairs, and he executed his duties zealously. This had the unfortunate effect of gaining Mallory few friends in naval service due to his support of unpopular legislation such as reinstating the use of corporal punishment and the formation of a Naval Retiring Board for older officers. Nevertheless, many of his actions went through and Mallory remained a capable chairman until the advent of the Secession Crisis.

As has been discussed extensively in other works, by the 1850s the Southern states had begun to feel underrepresented in Washington, and the question of slavery had become more and more pressing, especially with the acceptance of Kansas into the Union and the violent fighting over whether it should be a free or slave state. The Southern states were finally persuaded that if they did not act accordingly, they would lose their political power by the election of Abraham Lincoln as president in November 1860, without any votes from south of the Mason-Dixon Line (Still 1997:2-3). Therefore, on 20 December 1861, South Carolina, the center of anti-Union sentiments, seceded. By February, six others: Georgia, Alabama, Mississippi, Louisiana, Texas, and Florida, Senator Mallory’s home state, had followed suit.

During the Secession Crisis, Senator Mallory, like many other men of the South, was torn between conflicting duties to his home state and the federal government. In March 1861, this issue became null when the Senators from the seceded states were removed from the Senate rosters. Mallory himself, along with several other Southern politicians, had actually left office in February (Durkin 1954:121). Soon the future C.S. Naval Secretary was heading for Montgomery, Alabama, where both the Confederate government and Mallory's most challenging project were taking shape.

Montgomery was chosen as the first Confederate capital simply out of necessity. It was far from Union lines and the provisional Congress and Standing Committees, among them a Naval Affairs Committee, first met there on 19 February 1861. The previous day, Senator Jefferson Davis of Mississippi (Figure I.2) was sworn in as President. Davis would never interfere much in naval matters, and throughout the war seemed to relegate them to secondary importance. Mallory, therefore, always had nearly a free hand. Matters continued to move quickly, and the Confederate Navy Department was established on 20 February. Five days later, President Davis nominated Stephen Mallory to his Cabinet as Naval Secretary. The organization of a true Southern navy soon began. (Still 1997:3)

Following in a similar revolutionary pattern as that of 80 years before, the seceding states quickly set about establishing small state navies for local protection. The newly-established organization under Mallory ultimately inherited little from these ragtag forces, for the only vessels the seceded states were able to use were small steamers or other secondhand vessels. South Carolina's navy was certainly the best, although:

...it was [still] pitifully small, being composed of only the old sailing revenue cutter *Aiken*, one gun; tug *James Gray* (re-christened *Lady Davis*), a couple of small sailing boats, formerly in the Lighthouse Service, and three little steamers (*Catawba*, *Gordon*, and *Seabrook*), each with a small-caliber gun and fitted out haphazardly. (Still 1997:10)

Mississippi had no navy at all, choosing to concentrate instead on land defenses, while Mallory's home state of Florida had only a small ex-Coast Survey schooner. Alabama seized a revenue cutter and a Lighthouse Service tugboat, Georgia acquired two sidewheelers: *Savannah* and *Huntress*, while Louisiana and Texas only had three small revenue cutters between them (Still 1997:11). This was the entirety of the Confederate vessels obtained in the first round of secession, but Mallory later gained the steamers *Patrick Henry* and *Jamestown*, tug *Teaser*, and four other small vessels when the states of Virginia and North Carolina seceded. Even when fully armed and outfitted, the armament of all the state navy vessels combined amounted to no more than 20 guns, "not even the armament of a single U.S. sloop of war" (Still 1997:11).



FIGURE I.2. Jefferson Davis, President of the Confederate States of America (Still 1997:4; courtesy of Library of Congress)

Secretary Mallory and other Confederate leaders, despite the enormous organizational tasks they faced, understood that war with the Northern states was inevitable, and they must act quickly. Therefore, with what few vessels he had, Mallory set about organizing a naval infrastructure. When the Confederate capital was relocated to Richmond, Virginia, the Secretary and his assistants set up the Navy Department offices at the old Mechanic's Institute on 9th Street. Four departments were established: the Office of Orders and Detail, the Office of Ordnance and Hydrography, the Office of Provisions and Clothing, and the Office of Medicine and Surgery. In addition, a Confederate Marine Corps and the positions of Chief Naval Constructor and Engineer-in-Chief were subsequently created. All functioned very similarly to the venerable departments of the United States Navy (Wells 1971:3-4).

Starting with only that handful of vessels gained from the absorbed state navies, Mallory quickly implemented a mass building strategy to counter the numerically superior Union Navy. Due to his several years as Chairman of the Senate Naval Affairs Committee, and his great interest in new shipbuilding technologies, Secretary Mallory was keenly aware of the latest developments in naval armaments and armored vessels. He also took the initiative in developing new technologies, such as the use of mine (then called torpedo) warfare, submarines, and commerce raiding. Although these weapons had been occasionally used before, Mallory's adoption of them using modern technology of the 1860s allowed their use "...on a scale never before seen in naval war" (Still 1997:14). The nascent Confederate Navy stood poised to overwhelm the aging wooden ships of the Union with ultramodern cruisers and ironclads: quality against quantity, if only enough time could be had to fully realize the construction programs.

The Confederate Navy Secretary's approach to new construction was threefold: small, simple-to-construct wooden steam gunboats would be built in large numbers, allowing time for

smaller numbers of larger and more powerful ironclads to be built in conjunction with the construction or obtaining of cruisers, often from foreign contractors, for commerce raiding. While the commerce raiders were built primarily abroad due to the Confederacy's strong ties with Great Britain, the wooden gunboats and ironclads were largely contracted out to private builders throughout the Confederate States. By July 1861, the gunboat and ironclad programs were in full swing, and the first major commerce raiders, led by CSS *Sumter*, had begun their first depredations against Union merchant vessels (Durkin 1954:156). The Confederate Navy, although hastily organized with no important base to build on, had successfully begun operations.

The Confederate Ironclad Program

Of primary relevance to this study are the origins and first steps of ironclad construction as envisioned by Mallory and executed by a select few men. It is well-known that the Secretary had long been fascinated by the new rifled ordnance developed in Europe and the utilization of steam-driven ironclads. He therefore set out to enact a program centered on these two new weapons. While armored floating batteries had been tested in action during the Crimean War, the new technologies of explosive shells and rifled ordnance had not yet been combined onboard steam vessels with armor by the 1860s. Even though nearly 100 ironclads were built or building in Europe by the Civil War, they did not utilize rifled guns and still clung to auxiliary sail power. While ships like HMS *Warrior* were certainly powerful, Mallory intended his lesser ironclads to be a frontline "ultimate weapon" against the Union.

As former Chair of the Senate Naval Affairs Committee, Mallory had experience in funding ironclad construction projects, and he was soon successful in convincing the Confederate Congress to raise two million dollars for purchasing one or two European ironclads

(Holcombe 1993:7). His views on ironclads as the future of naval technology are easily seen, and often quoted, for they proved prophetic:

I regard the possession of an iron-armored ship as a matter of the first necessity. ... If to cope with them [Union Navy] upon the sea, we follow their example and build wooden ships, we shall have to construct several at one time... But inequality of numbers may be compensated by invulnerability, and thus not only does economy but naval success dictate the wisdom and expediency of iron against wood... (Scharf 1887:43)

Thus began the Southern ironclad program, both at home and abroad, for Mallory also began a massive building program for ironclads within the Confederate states. He was aided by several men of like mind in those early days of spring 1861. The most important among them were riverboat builder E.C. Murray of Kentucky, later builder of CSS *Louisiana*, Lieutenant John M. Brooke (Figure I.3), ordnance expert and later head of the Office of Ordnance and Hydrography, and Naval Constructor John L. Porter (Figure I.4), later Chief Naval Constructor and designer of nearly all Confederate ironclad types (Holcombe 1993:6-7). Although Porter had designed an ironclad as far back as 1846 (Figure I.5), and Murray proposed a design in April 1861, it was ultimately Brooke's ideas that were first incorporated into the type of ironclad Mallory desired. Many of Porter's concepts of 1846 were also used, as well as several new ones he had developed during the design process for a new Confederate ironclad. By June 1861, the process was well underway to constructing what Mallory saw as an ideal design.

It was determined jointly by Mallory, Brooke, Porter, and Engineer-in-Chief William P. Williamson that constructing the Brooke-Porter ironclad would be much easier if an existing vessel was converted. For this purpose the submerged, partially burned hulk of the former U.S. Steam Frigate USS *Merrimack* was selected (Figure I.6). It lay at the Confederacy's largest and most valuable naval facility: the Gosport (Norfolk) Navy Yard. *Merrimack*'s steam power plant was largely intact, allowing valuable time and money to be saved without the need of

constructing new machinery. Therefore, a burned-out steam frigate became the prototype Southern ironclad.

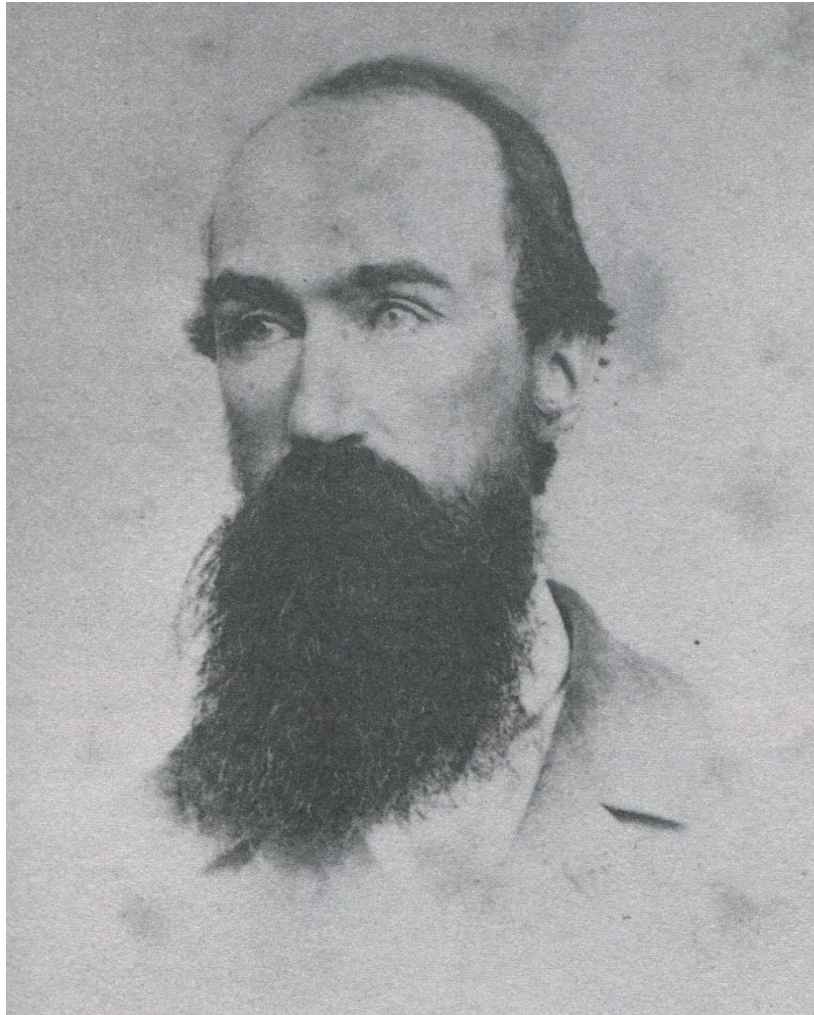

FIGURE I.3. John Mercer Brooke: scientist, inventor, and ordnance expert (Brooke 2002:88)

Merrimack, renamed *CSS Virginia*, utilized the semi-submerged ends, ram bow, and inclined, laminated armor casemate design developed by Brooke and Porter (Figures I.7 and I.8). A small, privately-built ironclad, *Manassas* (ex-*Enoch Train*) had been completed a year before in Louisiana but to an unconventional design. It was protected by a rounded shell of iron plate, containing room for only one forward-firing gun, and was the only Confederate ironclad not to use an angular casemate. *Manassas* ultimately remained more of a Mississippian curiosity during its brief career than a truly effective fighting vessel (Holcombe 1993:22).

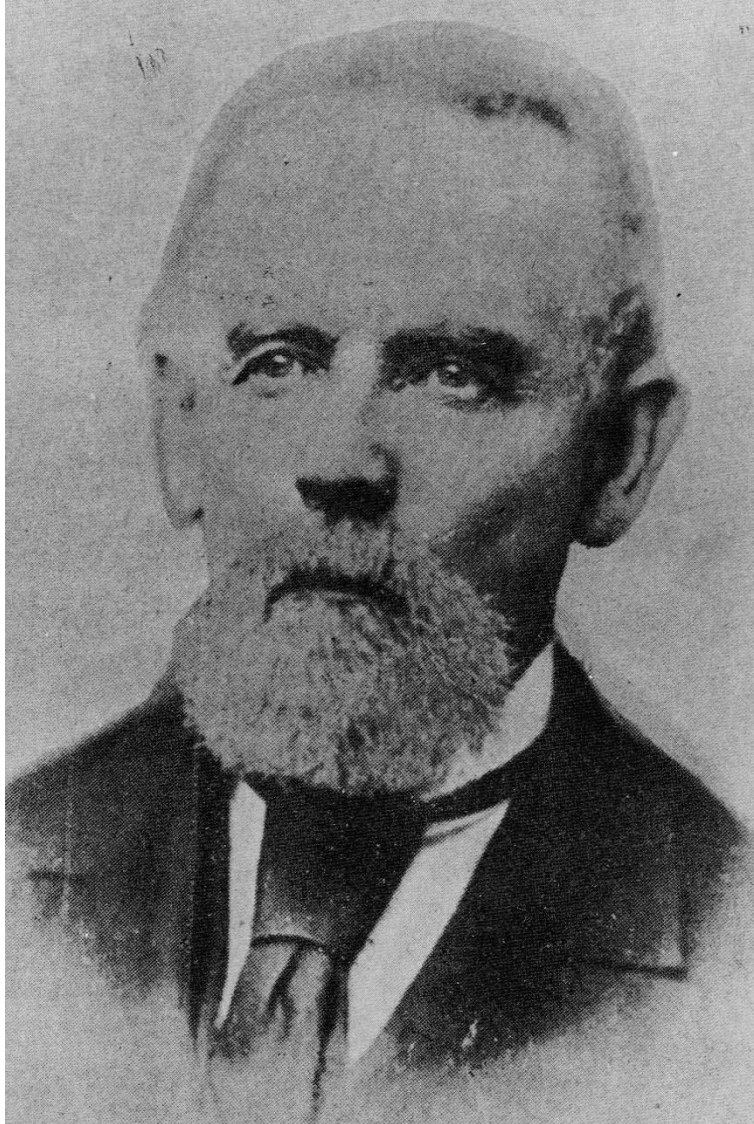

FIGURE I.4. Confederate Chief Naval Constructor John Luke Porter (Still 1997:32; courtesy of The Mariners' Museum)

Virginia was finished as far as possible in March 1862 and rushed into its fateful encounter with Union blockading forces in Hampton Roads on 8 March, from which it emerged victorious. Even more famous was the fight with the new Union ironclad USS *Monitor* the following day, on which much has been written. *Virginia* became the first Confederate ironclad to see action against another armored ship, and it set the trend toward the standard casemated harbor defense ironclads designed by Porter throughout the war. The casemate design was effective and simple to construct, and remained "...a distinctive feature of the Confederacy's

home-water armorclads” (Holcombe 1993:10). Although later armored vessels were significantly scaled down from *Virginia*’s massive size, they all retained the same general layout.

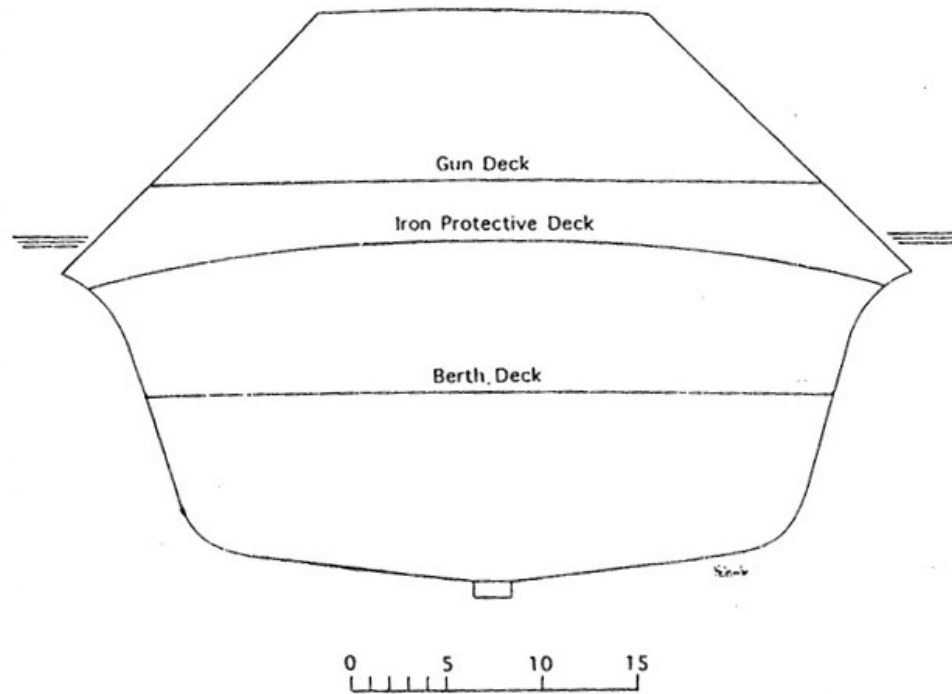

FIGURE I.5. Porter’s 1846 Pittsburgh ironclad design. It later became the basis for the Confederate *Richmond*-class ironclads. (Holcombe 1993:64)

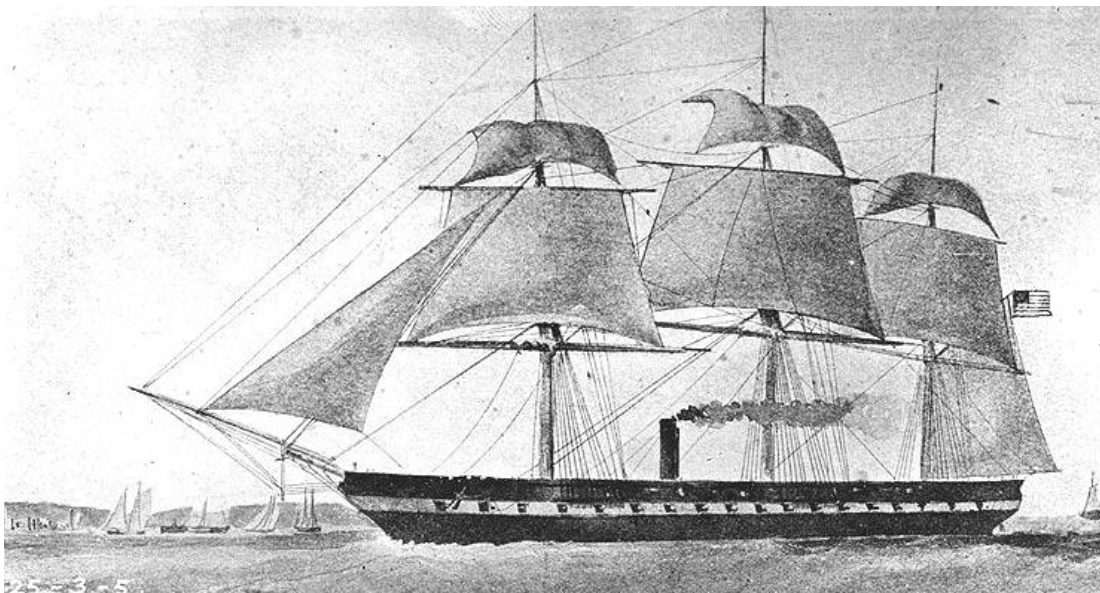

FIGURE I.6. A lithograph made of USS *Merrimack* during its 1856 visit to Southampton, UK. (Online Library of Selected Images, Naval Historical Center, Department of the Navy, Washington, DC, 2012)

Witnesses:
George Minor, Commander, C.S.N.
Charles J. Ost

John M. Brooke
Lieutenant C.S. Navy

[Annexed drawings]

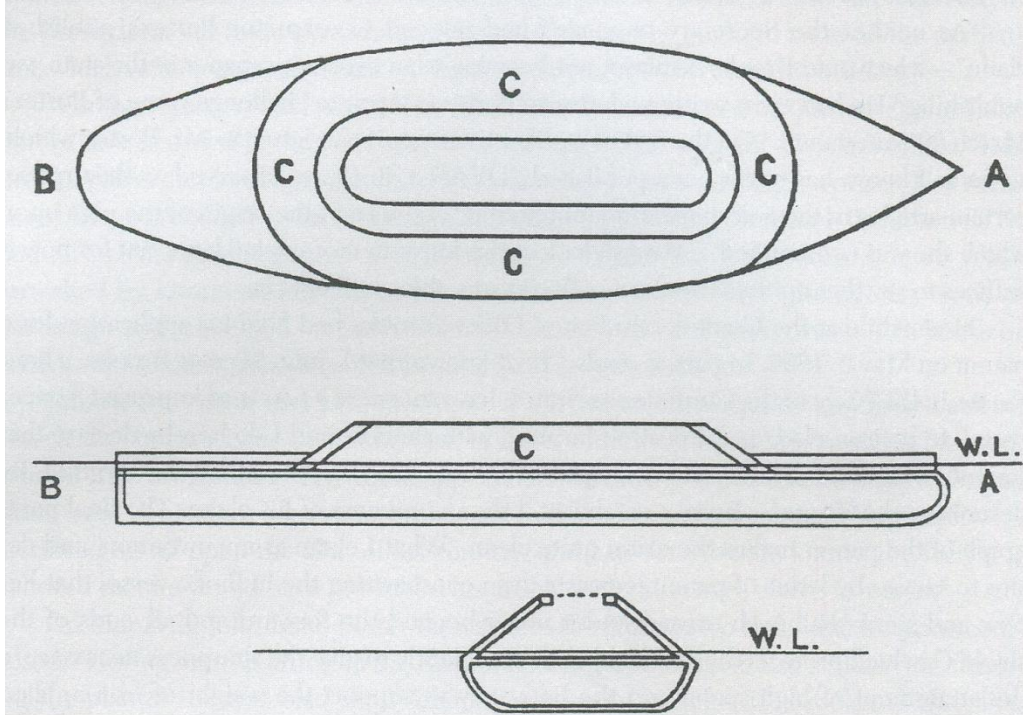

FIGURE I.7. Brooke's 1861 ironclad design, with submerged ends (Park 2007:60; from *Confederate Patent Office Report 1861*)

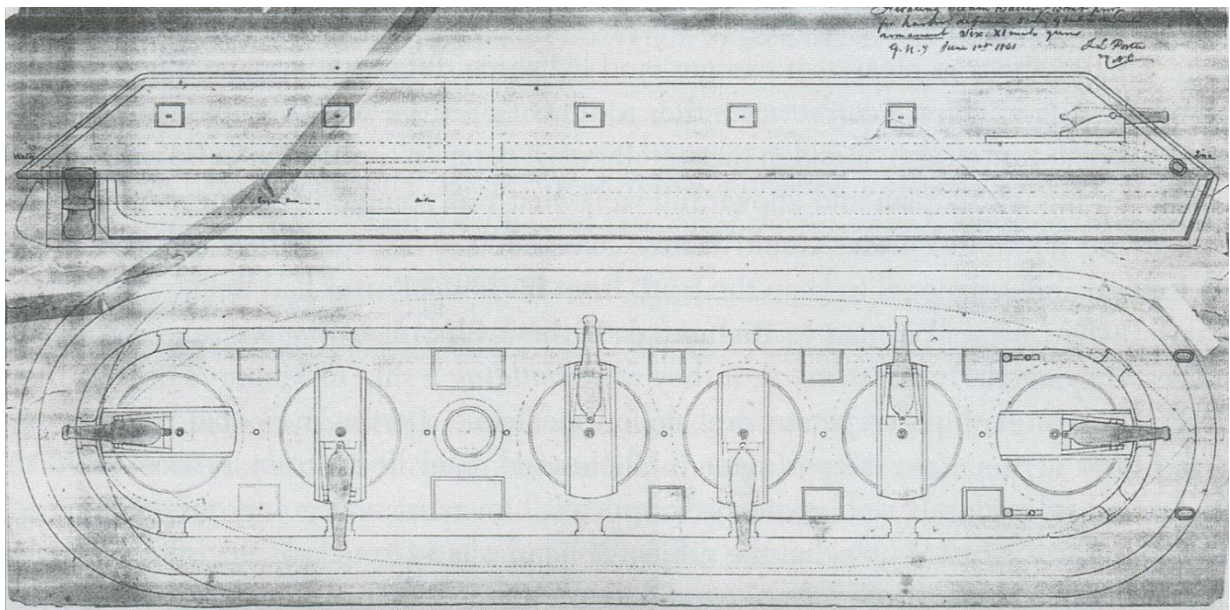

FIGURE I.8. Porter's 1861 ironclad design, with blunt ends (Park 2007:56; courtesy of The Mariners' Museum)

The home-built ironclad program as first envisioned by Mallory ultimately came to be the Confederacy's largest shipbuilding program, despite important early shifts in focus. Early ironclads such as *Virginia*, *Arkansas*, *Mississippi*, *Louisiana*, and *Georgia* were built to large, heavily armed, unconventional designs. This was the result of an "untested offensive strategy that required them to operate in both shallow harbors and rivers and at sea against Federal blockaders" (Holcombe 1993:39). The inability of the South to efficiently build and utilize vessels with such capabilities was only made apparent to Mallory's administration after the catastrophic losses of all these vessels except *Georgia*, which could only be used as a floating battery anyway. Thereafter, beginning in 1862, Confederate naval strategy shifted to the construction of smaller harbor defense ironclads of somewhat standardized design.

In the end, Secretary Mallory renewed his attempts to build or procure ironclads in Europe, but only one, CSS *Stonewall*, was actually delivered into Confederate hands. That vessel was commissioned too late to take active part in the war, and did not reach Western Atlantic waters until after General Lee's surrender in April 1865. While the European ironclad efforts can be considered a failure, Mallory's domestic program ultimately unfolded much as he had proposed in May 1861. By the end of the Civil War, the ironclad program was the largest naval construction effort in the South—the early wooden gunboat program had been entirely superseded—and over 50 ironclads had their keels laid (Holcombe 1993:151-155). Of these, only 25 were commissioned into active service. The Confederate ironclads helped greatly in delaying Union takeover of the Southern port cities despite their low numbers and success rates in timely construction and effective machinery. Mallory's strong grasp of and appreciation for new technology had made the miniscule Confederate Navy of 1861 into a pioneering and technologically advanced force to be reckoned with by 1865.

Confederate Ironclad Hull Types

Confederate ironclads can ultimately be grouped into five categories based on hull type: conversions, early non-standard types, standard hull designs, diamond hull designs, and late-war types. All are covered in great detail in A. Robert Holcombe, Jr.'s 1993 MA thesis, "The Evolution of Confederate Ironclad Design", but require some explanation here. All 27 Confederate ironclads discussed in this thesis fall under these categories. In brief, the conversions were *Manassas*, *Virginia*, and *Baltic*; the early non-standard types were *Arkansas*, *Mississippi*, *Louisiana*, and *Georgia*; the standard hull designs were the "Richmond-class" (*Richmond*, *Chicora*, *Palmetto State*, *North Carolina*, *Raleigh*, *Savannah*), "Tennessee-class" (*Tennessee*, *Columbia*), vessels designed by Acting Naval Constructor William Graves (*Charleston*, *Virginia II*), and large sidewheelers (*Nashville*); the diamond hull designs were *Tuscaloosa*, *Huntsville*, *Albemarle*, *Neuse*, *Fredericksburg*, *Missouri*, and *Jackson*; finally, the late-war ironclads were *Milledgeville* and *Wilmington*. All groupings contain other ironclads that were never finished or even named in some cases, and others contain vessels that were either foreign-built or contained foreign-built machinery, which is not discussed in this study.

Some vessels were never completed, but came close enough that significant details are known. Namely, these are *Mississippi*, *Jackson*, *Milledgeville*, and *Wilmington*. In addition, there remains some doubt about the exact hull configurations of *Nashville*, for now listed as "standard hulled," and *Tuscaloosa* and *Huntsville*, for now listed as "diamond hulled" (Holcombe 1993:83-84,93-95). Fortunately, these latter two ironclads are preserved in the archaeological record, making future positive identification of hull structure likely.

Explanation of the exact configurations of the different types permits a better understanding of their machinery requirements and layout. The converted ironclads varied

greatly: *Manassas* was formerly the twin-screw towboat *Enoch Train*, *Virginia* was formerly the USS *Merrimack*, a single-screw auxiliary steam frigate, and *Baltic* was formerly a sidewheel towboat and cotton lighter (Still 1985:80). Among the early non-standard ironclads, *Arkansas*'s design combined elements of both riverboats and coastal steamers in a twin-screw layout, while *Mississippi*'s layout reflected the intention of expediting construction time and employing unskilled labor. It was accordingly utterly devoid of shiplike curves. *Mississippi* was also one of the first triple-screw vessels constructed (Holcombe 1993:44-45).

Louisiana was similar to *Mississippi* in that its hull contained few or no curves, but its power plant was very unusual, consisting of two center paddlewheels mounted one behind the other, and two small propellers for steering. Almost nothing is known currently about *Georgia*'s hull design other than that it must have been simple and was provided with two propellers (Panamerican Consultants, Inc. [PCI] and Tidewater Atlantic Research [TAR] 2007:14).

The standard hull ironclads are, appropriately, much more easily grouped. The six vessels of the *Richmond*-class, although differing slightly in casemate and pilothouse layout, employed the same hull design as seen in Figure I.9. All were driven by a single ten-foot diameter screw (Holcombe 1993:68). In a similar vein, the *Tennessee*-class vessels employed a standard hull form, but with greatly differing casemate designs and armor layout, as seen in Figure I.10. They were single-screw, although *Columbia* was originally planned to carry two.

Those ironclads designed by William Graves, *Charleston* and *Virginia II*, for the most part followed the same layout as the previous classes, but were larger with more rounded bilges (Figure I.11). These vessels were also fitted with a single propeller and carried rams of an unusual protruding design.

As previously stated, the exact hull configuration of *Nashville* is unknown, although it appears to have been of the standard type (Holcombe 1993:83). This ironclad was a massive vessel propelled by sidewheels, and was the only Confederate ironclad to have equipped sidewheels besides the converted *Baltic*.

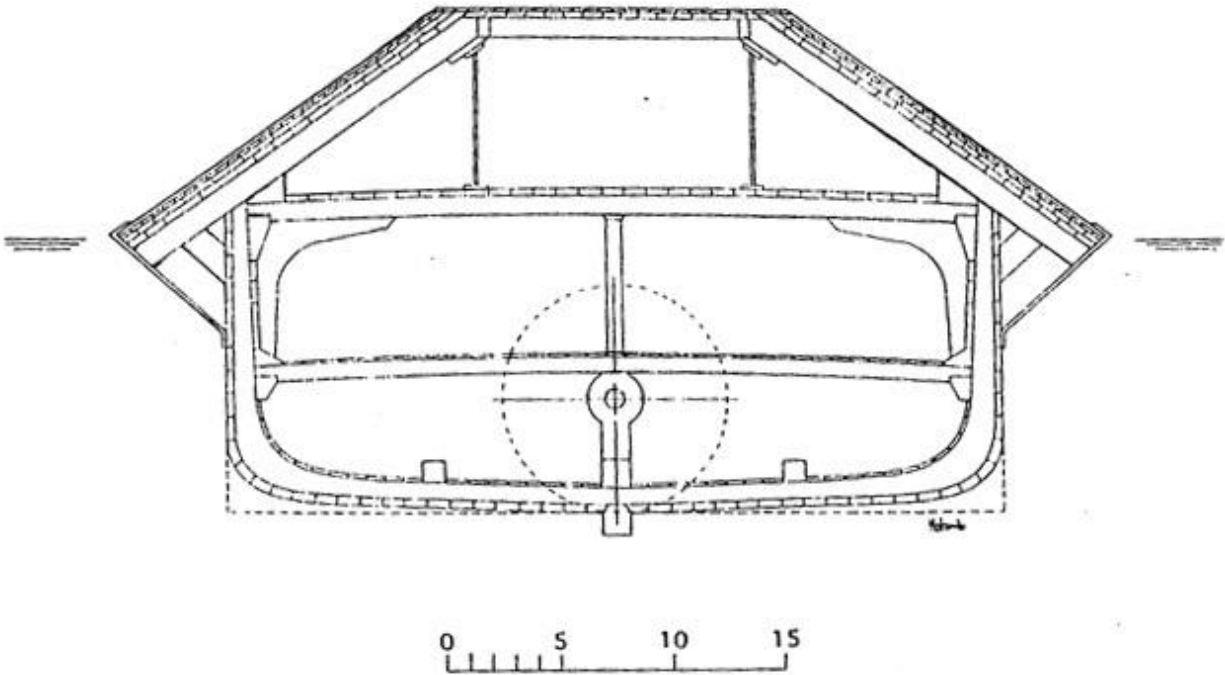

FIGURE I.9. Midships section of a *Richmond*-class ironclad (Holcombe 1993:67)

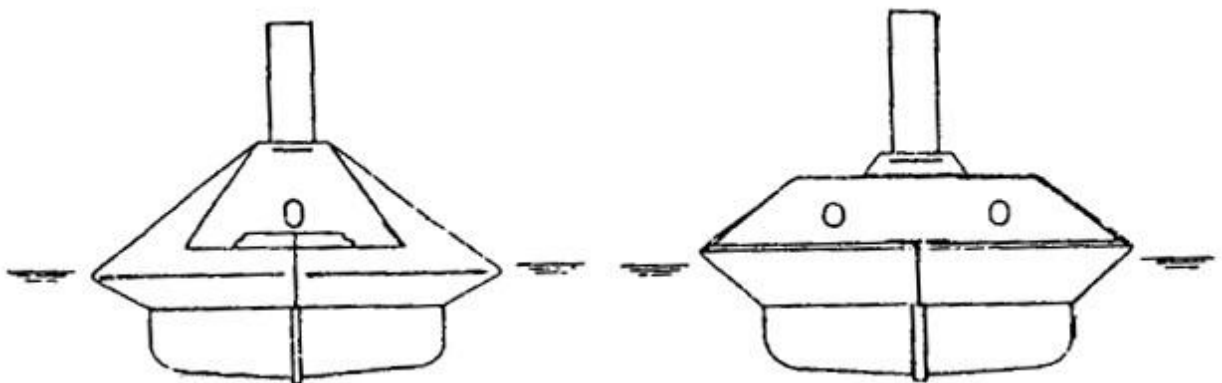

FIGURE I.10. Comparative bow views of sister ships *Tennessee*, left, and *Columbia*, right (Adapted from Holcombe 1996:71,73)

Following the more traditional hull layout of the standard types, the diamond hull ironclads utilized a design intended for ease of construction and shallow draft (Holcombe

1993:92). As many curves as possible were eliminated from the hull, resulting in a hexagonal, or “diamond” cross-section (Figure I.12). The diamond hull ironclads differed based on size and propulsion. Almost nothing is known about the exact layout of *Tuscaloosa* and *Huntsville*, but they are thought to have been twin-screw (Holcombe 1993:94). *Albemarle*, *Neuse*, and *Fredericksburg* employed twin-screw propulsion, while *Missouri* and *Jackson* were designed for a center paddlewheel. *Jackson* was altered in the course of construction to mount twin screws, making *Missouri* the only completed Confederate centerwheel ironclad (Holcombe 1993:108).

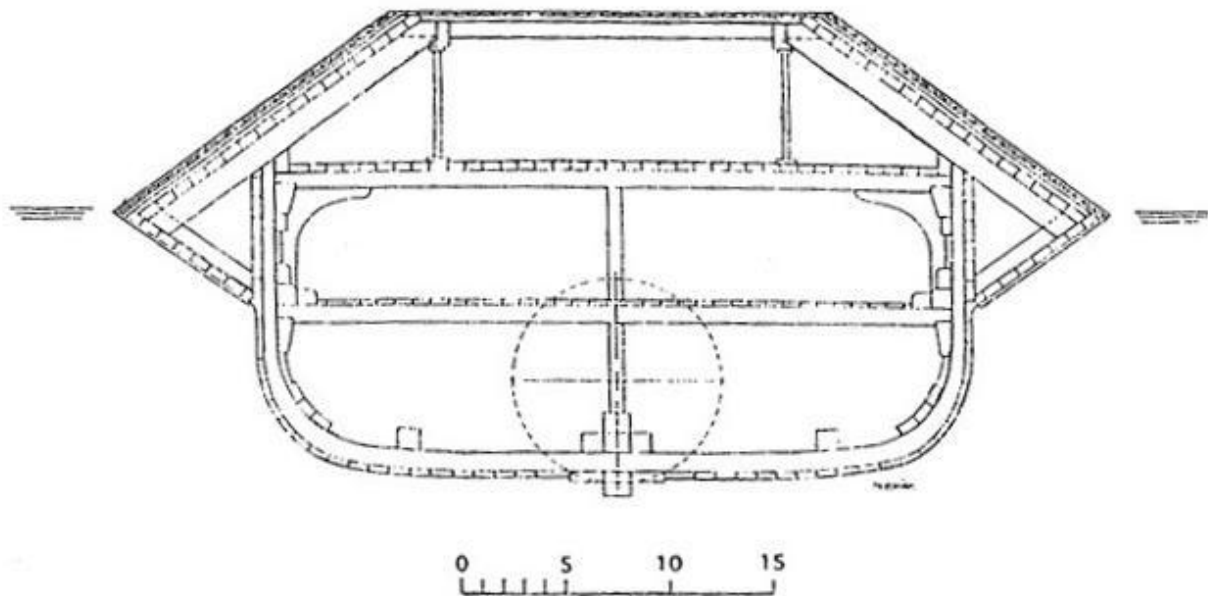

FIGURE I.11. Midships section of *Virginia II* (Holcombe 1993:81)

The final two ironclads for which significant engineering data exists were never finished, but they differed greatly in design. *Milledgeville* was an improved version of the standard hull type, employing twin screws and a greatly-improved armor configuration. Figure I.13 shows a midships section of the vessel. Its most important difference was a lighter draft than the standard hulls (Holcombe 1993:125).

Wilmington was one of the very last ironclads designed in the Confederacy. From the outset it appears to have been intended to be a blockade-breaker. In cross-section this ironclad

reflects similar improvements in the standard hull form as employed in *Milledgeville*, but sports a deeper draft and very fine lines (Holcombe 1993:128). Figure I.14 represents this configuration. Like *Milledgeville*, *Wilmington* was driven by twin screws and appears to have lacked a ram. Neither of these two ironclads were completed, but their designs certainly represented great improvements in hull and machinery layout.

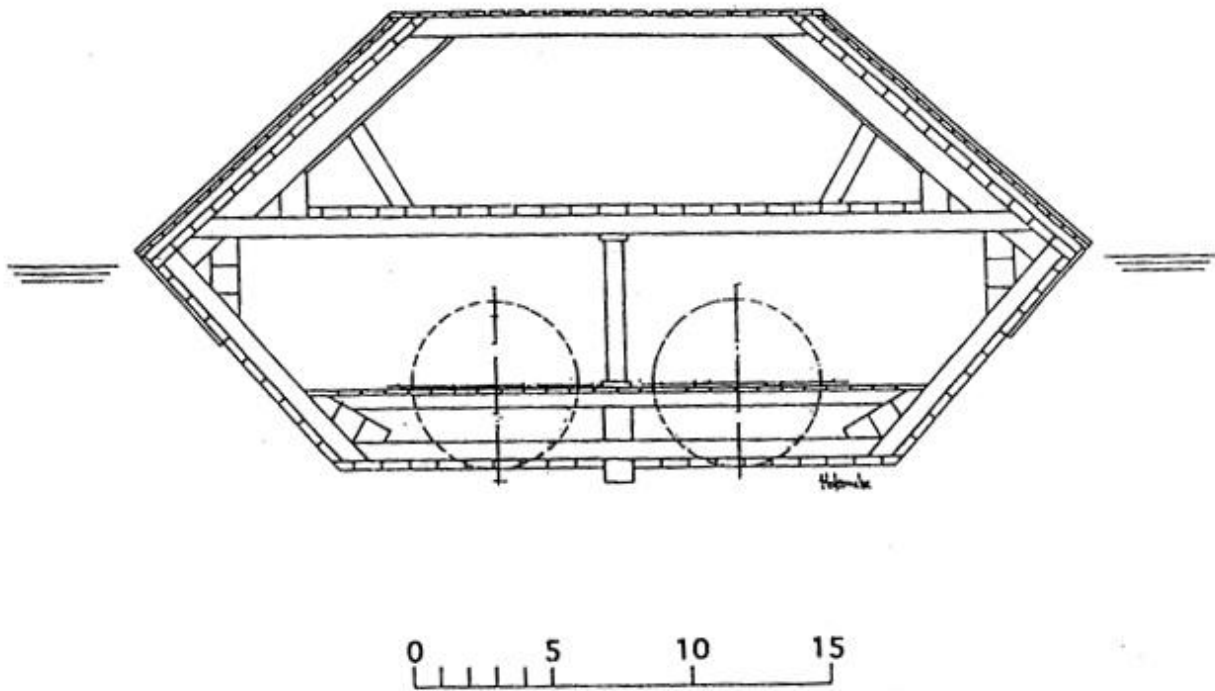

FIGURE I.12. Midships section of *Albemarle* (Holcombe 1993:99)

The evolution of ironclad hull forms reflected a continuous trend toward better, cheaper, and more easily-constructed vessels by war's end. Acquisition or construction of steam machinery also played an important part in this process. It has been seen that Secretary Mallory and "...the Navy Department made conscious efforts to ... improve the basic ironclad model established by the *Virginia*" (Holcombe 1993:147). Although less successful in the long run with providing totally reliable engines, the Confederate ironclad program still achieved notable successes in the field of marine steam engineering. Unfortunately, these successes did not guarantee to make the mid-1800s American steam engineer's job any easier.

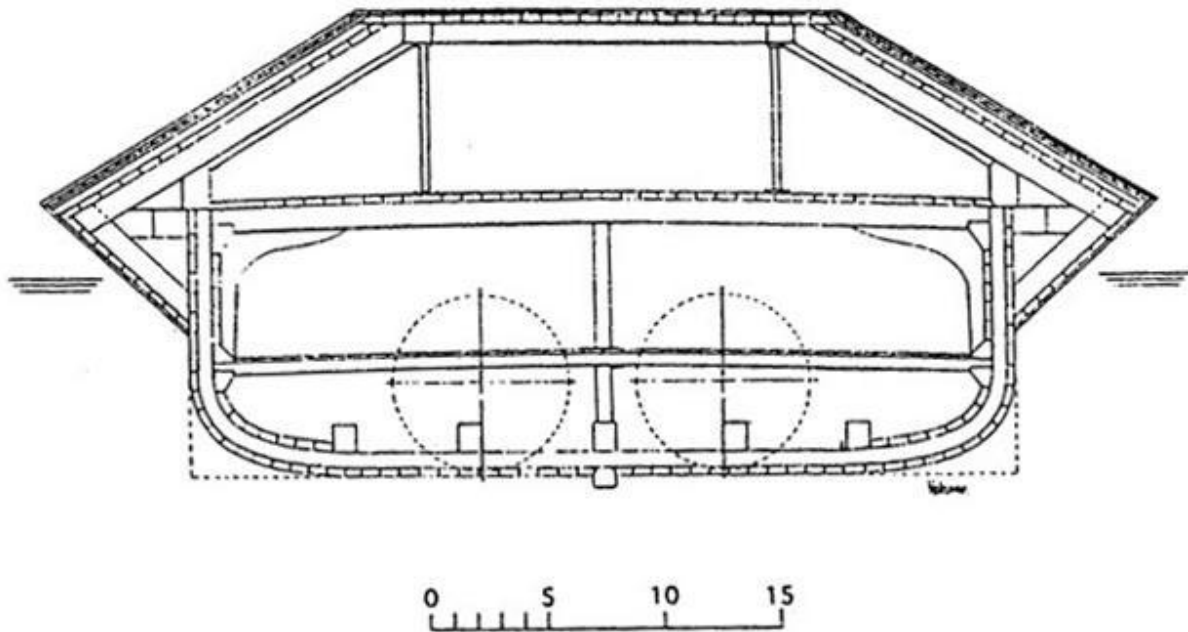

FIGURE I.13. Midships section of *Milledgeville* (Holcombe 1993:125)

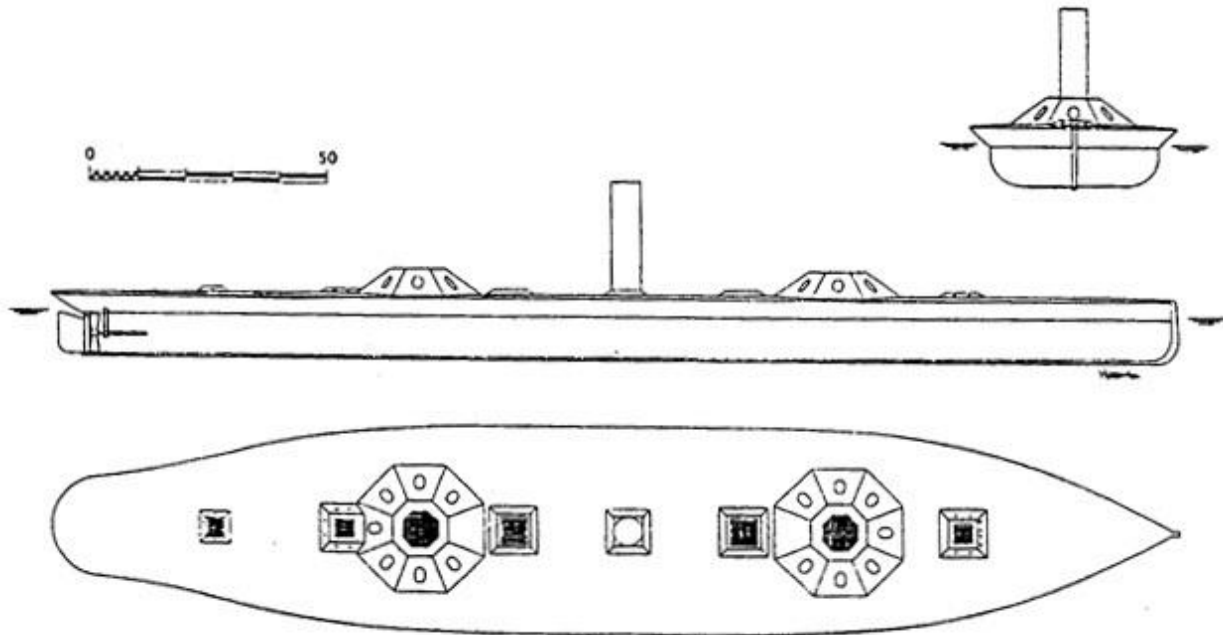

FIGURE I.14. Sheer, body, and plan views of *Wilmington* (Holcombe 1993:129)

Marine Steam Engine Operations in the Mid-19th Century

Marine steam engines of the Civil War era were quite different from the complicated triple- and quadruple-expansion behemoths that powered most ships of the late 19th- to mid-20th

centuries. Steam power in the 1860s was still a relatively new technology, and as such, it remained simple and full of quirks that had not yet been studied exhaustively. Operating a steam engine onboard a vessel, especially those on poorly-ventilated warships such as ironclads, required a special type of seaman, the naval engineer.

By the Civil War, "...engineering was still a comparatively new field in the navy, [and] the status of engineers was not [yet] clearly defined" (Wells 1971:107). Engineering duties encompassed a wide range of functions, and more were added as steam plants grew in complexity. The engineers of the Confederate Navy were not immune to this trend, although engines onboard Confederate vessels were often simpler than those in other navies.

The steam engineers of the Confederate Navy were organized similarly to those of the U.S. Navy. An Engineer-in-Chief, William P. Williamson, answered directly to Secretary Mallory, while under him there were four ranks of engineering officers. One of these was commissioned, the chief engineer, and three were warrant: first, second, and third assistant engineers (Wells 1971:107). In addition to the officers, the engine and boiler room crews contained a variable number of coal heavers (these were the days before the term "stoker" came into common usage) and firemen. Coal heavers were mostly unskilled, but firemen were "...supposed...to manage fires with different kinds of fuel... [and be capable] of handling the engines without supervision..." (Wells 1971:115). Firemen were also required to have some skill in repair and maintenance.

Besides ensuring the smooth operation of a warship's steam plant, it was the duty of the engine room crew, who usually numbered about twenty on the ironclads, to affect necessary repairs onboard (Wells 1971:117). Only the most difficult jobs such as replacing cylinders, valves, or shafts were given over to outside works such as the Charlotte Navy Yard. During

repair procedures or in anything to do with the propulsion systems of the warship, the chief engineer often had authority approaching even that of the captain, and many disputes among the executive officers of the vessel and the engineers would arise because of this (Wells 1971:114). Like the technology of steam propulsion itself, the scope of authority of naval engineering officers was not fully defined in the 1860s.

Terminology was also a bit different than in later times. It appears that a good deal of modern confusion over the true number of engines onboard the ironclads and other vessels has come from the 19th century use of the term “engine.” As Brown (1993:67) states:

Contemporary usage defined each cylinder as an ‘engine’ and hence multi-cylinder machinery took the plural—engines. For example, ... [a vessel] fitted with ‘two engines of 100HP each’ ... [would] Today... be described as a single 2-cylinder engine of 200HP.

The number of engines onboard the Confederate ironclads in particular has thus often been confused. Part of the problem lies in the fact that vessels with multiple screws often could not operate them separately, as all units were linked. There were a few exceptions, but usually “...all boilers gave steam to all engines and it was impossible to run with one engine crippled, unless the engines were stopped and the disabled unit disconnected” (Wells 1971:116). Many of the twin-screw Confederate ironclads, such as *Albemarle*, followed this pattern.

Types of fuel used onboard mid-19th century vessels also varied widely. Western river steamboats nearly always used wood, while naval vessels burned coal of varying types—oil had not yet been developed as a fuel source for marine boilers. The Confederate Navy often had to rely on a combination of wood and coal for its vessels, even the ironclads, due to its chronic shortage of resources during the war. Coal from North Carolina was usually fairly abundant, but was considered almost as bad as wood for the amount of smoke it gave off (Wells 1971:116). Wood often had to be resorted to while in port and even occasionally while in action.

Starting a steam engine in the days before separate starting engines were widely utilized was a monstrous task. Once a suitable amount of coal or wood had been procured, steam was accordingly built up in the boilers. This was often much more risky than in later years, especially onboard riverboats, for the firetube or flue boilers in common use at the time exploded much more easily than later watertube models. Once a sufficient head of steam was built up, the entire engine room crew on duty needed to work together, as described by Bathe 1951:5-6:

First, the whole of the engine had to be slowly warmed up by live steam, then steam was by-passed from the valve chest into the condenser to expel the air. After all was ready, the crew had to bar the crankshaft round a few times by main force...., then the condenser injection valve was opened and the chief engineer, praying for a good vacuum in his engine, moved over the steam throttle a notch or two and hoped for the best.

Figure I.15 shows a humorous but largely accurate depiction of this unenviable process.



FIGURE I.15. “Barring,” or turning over a steam engine for startup (Bathe 1951: Plate II)

Starting the high-pressure non-condensing engines of Western riverboats was a slightly different procedure. The typical lever and wiper setup (Figure I.16) had first to be configured by lifting the levers off the wipers. “To start the engine the reversing link, block, or sawbuck is set to the desired direction. Next, the levers are lowered to the wipers, and, finally, the throttle is opened” (Bates 1996:51). This procedure was made less arduous by the smaller size of riverboat engines and their open design with easy access.

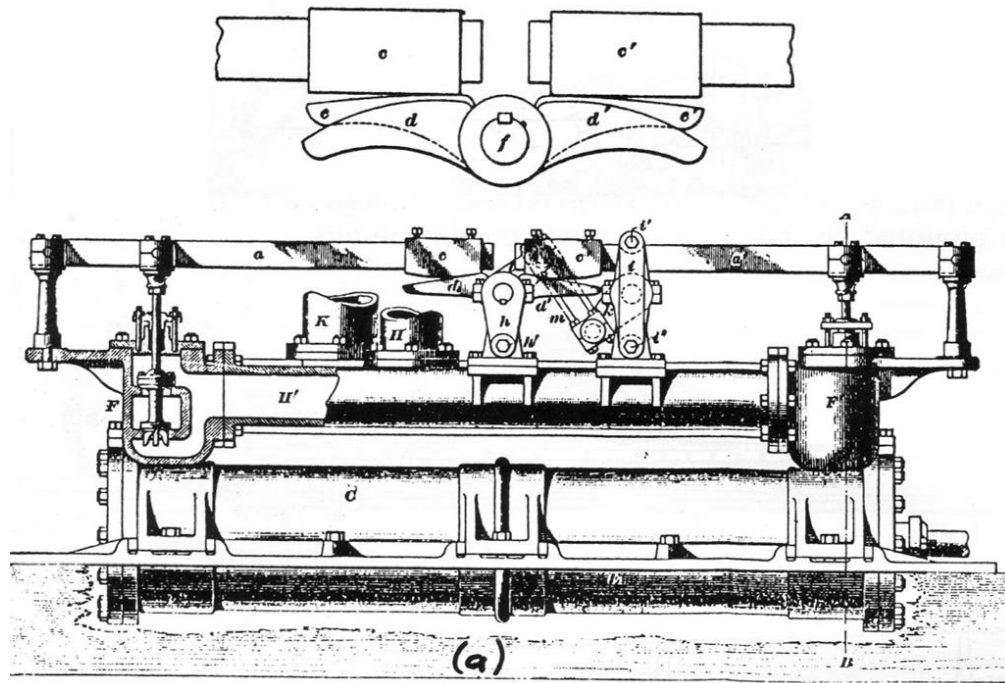

FIGURE I.16. Levers and wipers of a typical high-pressure riverboat engine. The setup is positioned on the top center of the engine cylinder as seen in the expanded view. (Adapted from Bates 1996:41-42)

Once the vessel’s power plant was running, typical operational procedures involved maintaining proper boiler water levels, monitoring engine functions, awaiting orders from the helm, and simply trying to survive in the extreme heat. Making sure the boilers contained enough cooling water was perhaps the most important of these tasks, as overheated or unclean boilers had a nasty tendency to explode, especially the high-pressure systems onboard Western river steamboats. Consequently, during each voyage, the mud drums, which collected sediment from

the boilers, were “blown out” several times (Bates 1996:10). While this practice was most common onboard river steamers, it was also necessary for coastal and harbor defense vessels like the majority of the Confederate ironclads.

Monitoring engine functions still mostly involved simple observation and an engineer’s “feel” for his engines during the 1860s. Glass gauges for monitoring steam pressure, lubricant levels, etc. were fairly uncommon, being considered unreliable, dangerous, and, at best, a “dubious innovation” (Bathe 1951:6). Safety valves were rarely equipped with any tamper-proof mechanism, and direct observation of troublesome areas was often hindered by cramped machinery spaces. As a result, engineers of the Civil War navies most often had to rely on sheer familiarity with their charges.

Orders to the engine room onboard Confederate ironclads or other mid-19th century vessels were relayed by a combination of bells or shouted orders. Several ironclads had their pilot houses and helm stations positioned directly over the engine room, making dispersal of orders simpler and faster. Shifting gears was the most common ordered task, but, like starting the engine, it was labor-intensive. There were several different gear types in common use by the Civil War, but all functioned similarly, differing mainly in complexity. One of the simplest, most common and versatile was the Stephenson valve gear, seen in Figure I.17.

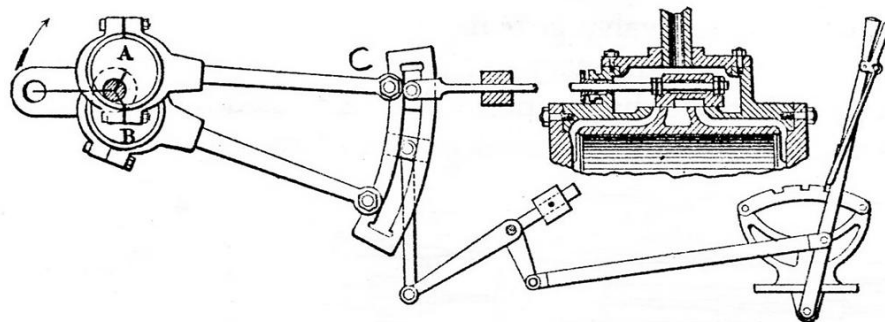

FIGURE I.17. Stephenson valve gear. This setup was also commonly employed by steam locomotives, for which it was originally invented. Moving the lever attached to the link motion allows for forward, reverse, and a nearly infinite range of adjustments if the engineer’s strength holds out. (Bates 1996:47)

In addition to other miscellaneous duties such as occasionally running bilge pumps, testing fire pumps, and taking onboard fresh boiler water (using the so-called “doctor” engine, if present), a Civil War engineer’s main concern was trying to endure the extreme heat of the engines and boiler furnaces. There were rarely, if ever, provisions made in the early days of steam for proper ventilation of the below-deck spaces other than hatches and gunports (Bathe 1951:6). The problem was made even worse onboard the ironclads with their layers of insulating armor and dearth of hatches. As a consequence, the amount of air reaching the furnaces was usually insufficient for ideal combustion, and this, combined with a reliance on natural draft and almost complete lack of insulation on the boilers and steam lines led to excruciating conditions in the machinery spaces. It was not uncommon for the men to endure temperatures over 120° Fahrenheit, and onboard at least one ironclad, CSS *Richmond*, temperatures were reported to exceed 150° on occasion (*Official Records, Navies* 1987 [Ser. 1, Vol. 10]:792). Exposed parts of the boilers, such as the stack breechings, could be seen to glow red even in daylight, and gases from the furnaces often permeated the living quarters, further contributing to the ill effects of serving onboard an ironclad for any length of time (Wells 1971:149). Little wonder then that it was typical for an engineer’s appearance to vary greatly between watches, shown in Figure I.18.

It can readily be seen that the duties involved in maintaining and operating an 1860s marine steam plant were varied, dangerous, and labor-intensive. Engineers of the day were required to be familiar with not only a high degree of technical detail, but operate based on gut instinct and sheer strength. Their relatively new place in the hierarchy of naval officers often brought them into conflict and led to confusion about the full extent of their duties. During the Civil War, these problems remained common, but like many other aspects of steam engineering at that time, progress was made.



FIGURE I.18. Appearance of an engineering officer going on watch, left, and coming off, right (Bathe 1951:Plate II; sketch by Robert Weir 1862)

The veteran engineers of the Civil War navies observed and experienced firsthand the transition from combined sail and steam power to vessels driven purely by steam. This change happened especially early onboard the ironclads. Experience gained during wartime service allowed for the effective training of the next generation to serve on vessels built after the transition from sail to steam, and wood to iron was complete. Similarly, in their time the marine steam engineers of the Civil War had been trained by men who had seen the very earliest marine steam engines in operation, one of the first great revolutions of the 19th century.

CHAPTER 2: THE DEVELOPMENT OF STEAM-DRIVEN ARMORED VESSELS

Technological developments during the nineteenth century were myriad and important. In the span of 100 years, transportation was revolutionized by railways, steamships, and, at the end of the century, automobiles. Gas lighting, then electricity introduced reliable sources of artificial light to whole communities. Scientific and technological progress rushed forward at an incredible pace, and even became a popular social topic of the day. Often sparking in the popular imagination during these times was the new science of marine engineering and naval technology coupled with advances in gunnery and armor plating. By the time of the Civil War, the leading world powers of Great Britain and France, and to a lesser extent the United States, had made great strides in providing reliable steam power to warships.

Unquestionably the leader in both political power and technology throughout most of the 19th century was Great Britain. Although France often followed close behind in new technology, Britain was at most times at least a generation ahead of American engineering practice. Steam power came of age in the period between 1811 and 1860 mainly due to British engineers, although mercantile developments in America should not be overlooked. The great British yards pioneered developments in iron and steel ship construction as well, producing at one time some 80 percent of the world's seagoing steam vessels (Smith 1937:2). Therefore, any discussion of armored steam warship development must relate primarily to Britain.

According to Lambert (1992:14), "The steam engine was the first major manifestation of the industrial revolution to have a profound impact on warship design". Although many independent inventors had experimented with steam power dating back into the 1500s or even earlier, it was primarily the work of Thomas Newcomen and James Watt that led to the first practical steam engine in 1775. Newcomen's original engine design of 1712 had been greatly

improved upon by Watt, but was designed primarily for pumping wells or mineshafts as seen in Figure II.1. It did not take long for others to realize steam power's potential for transportation. Indeed, experiments with steam-powered vessels were reportedly carried out in France as early as 1776 and 1783. These did not have much influence on the introduction of steam navigation (Smith 1937:4), while later advances made in Britain by men such as Napier and Ericsson generally pointed the way forward. In the United States, pioneers such as Robert Fulton developed steamboats for mercantile purposes. In particular, Fulton's designs for river paddlewheelers eventually gave rise to that classic symbol of American ingenuity, the Western river steamboat. In any case, by about 1800 serious attention was being given to steam propulsion on both sides of the Atlantic. (Smith 1937:143; Brown 1990:44)

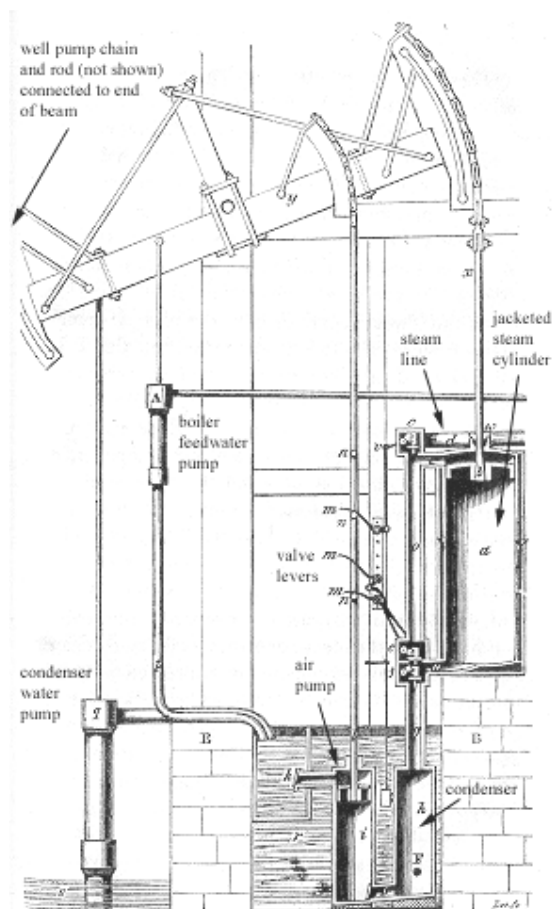

FIGURE II.1. Boulton and Watt pumping engine, post-1775 (Courtesy of Carl T. Lira 2006; from Stuart 1824:114)

The earliest steam-driven vessels were paddlewheel propelled, but lacked several qualities found in sailing line-of-battle ships that limited their strategic use. Despite these deficiencies, the steam warship had been mostly accepted in the major fleets by 1830. As usual, the Royal Navy led the way in development and application of this new technology, although at first it often had to turn to private shipyards for new construction. As in the United States, British mercantile interests were quick to apply steam machinery to new vessels in the interest of regular schedules for greater profit. They were not constrained by worries of effectiveness in battle or long-distance voyages. As a result, steam technology often developed much more quickly in the private sector than in the military. (Brown 1990:44; Lambert 1992:14-16)

It has often been said that the major navies were against the new technology, but in fact the Royal Navy carefully studied steam, taking a cautious and experimental approach. France attempted to closely follow British practices but was forced to rely on British-built machinery. Progress was made slowly but gradually, with time given over to carefully testing new designs. There was no rush into steam technology simply because it was not yet proven, but important results were soon forthcoming.

The First Steam-Powered Warships

Despite lagging behind Britain and France in naval technology, the United States Navy utilized the first practical steam warship, Robert Fulton's *Demologos* of 1815. This vessel was a catamaran gunboat with a single paddlewheel mounted between the hulls, and was designed as a floating battery (Figure II.2). Although strongly-built, *Demologos* was capable of only 5.5 knots and reflected America's policy of coast defense during the War of 1812 period (Lambert 1992:19). Several nations expressed interest in the design, including France, but *Demologos*

remained a one-off warship. No similar designs were ever utilized in the United States or elsewhere, although the self-powered floating battery concept did not die for some time.

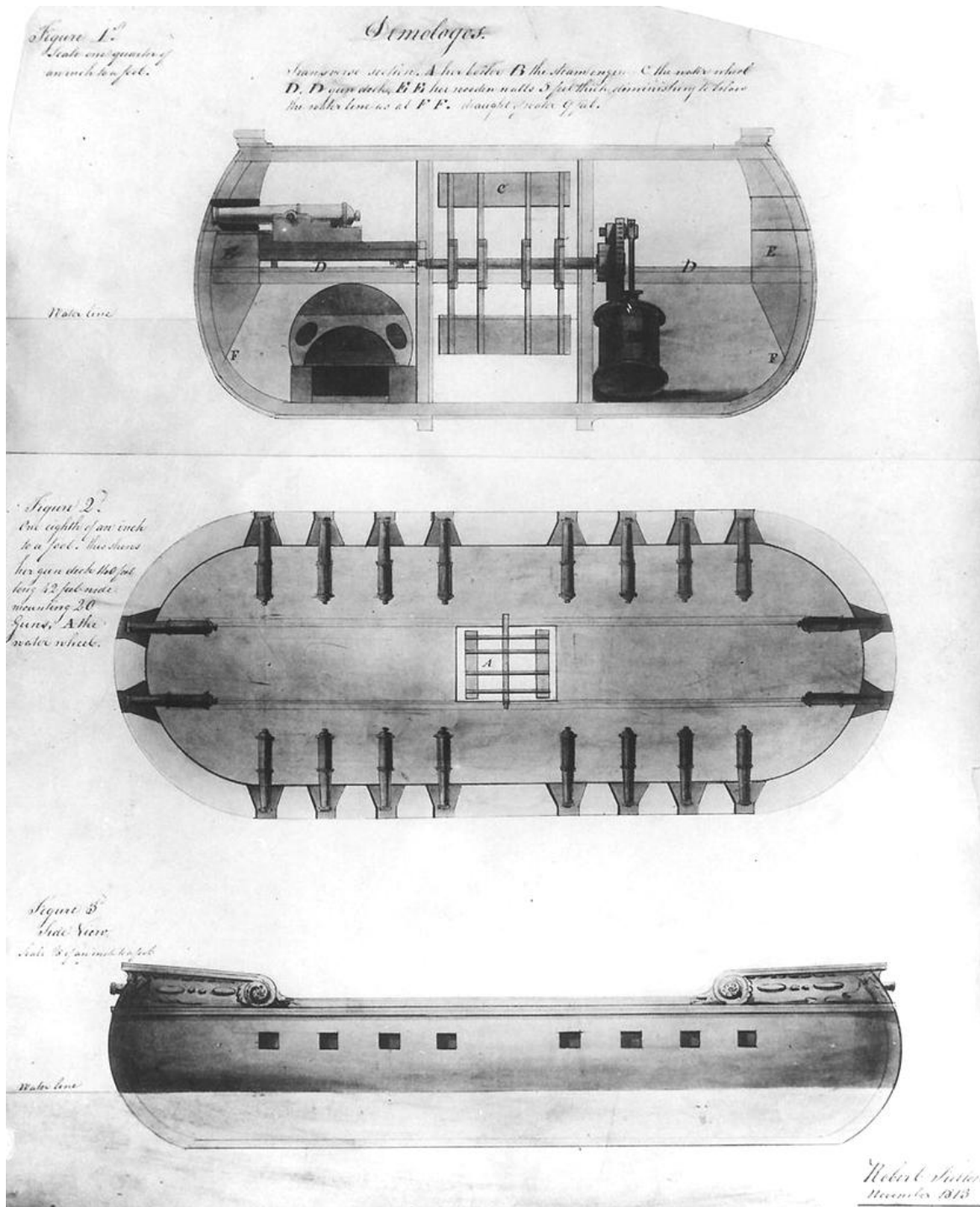

FIGURE II.2. Plans of “Fulton’s Steam Battery” of 1815, officially named *Demologos*; the world’s first steam-powered warship. These were drawn by Fulton himself. As finished the ship was also equipped with lateen sails on two masts. (Online Library of Selected Images, Naval Historical Center, Department of the Navy, Washington, DC, 2012)

Developments in Great Britain among the mercantile fleets closely followed the exploits of the famous early American steamers such as Colonel John Stevens's *Little Juliana* of 1804 and Fulton's *North River Steamboat of Clermont* of 1806. The British contemporaries to these pioneering vessels were William Symington's *Charlotte Dundas* of 1801 and Henry Bell's *Comet* of 1812 (Smith 1937:13-14). All of these vessels were civilian and designed for local service on rivers or harbors. The Royal Navy studied the improvements in steam propulsion made in these vessels and others, and in 1815 the decision was made to convert the small vessel *Congo*, intended for exploring the river of that name, into a steamer. A 20-horsepower Boulton & Watt beam engine (Figure II.3) was accordingly installed, but *Congo*'s trials revealed the deficiencies of putting engines into hulls designed for sail (Lambert 1992:15). With these disappointing results, naval interest in building steam-powered warships declined for a time.

After the famous and successful voyage of the small steamer *Enterprise* to India in 1825, the possibilities of steam propulsion over long distances were considered. New engines were much more capable than those first used, and naval shipbuilders better understood how to combine efficient hull design for paddlewheels with that of sail. Perhaps the Royal Navy's first successful steam warship was HMS *Comet* of 1822 (Lambert 1992:17). This vessel was intended primarily for towing, and several later vessels were built for similar purpose. Up to 1830, this auxiliary role was common in both the British and French navies. During the same period the French still relied on British companies for machinery, but constructed their first naval steamers, *Africain* and *Voyager* in 1818 (Lambert 1992:18). All of the steam warships, British, French, and American, built during this time period reflected the inadequacy of steam to propel large warships or oceangoing steamers effectively for long distances. It was also difficult to mount many guns in a hull filled with bulky and exposed paddlewheel machinery. This made

paddlewheelers unsuitable for the battle line, but their ability to mount large fore- and aft-firing guns, coupled with long range under steam and sail, made them ideal for use as cruisers once that strategy was fully developed (Rodgers 1996:31).

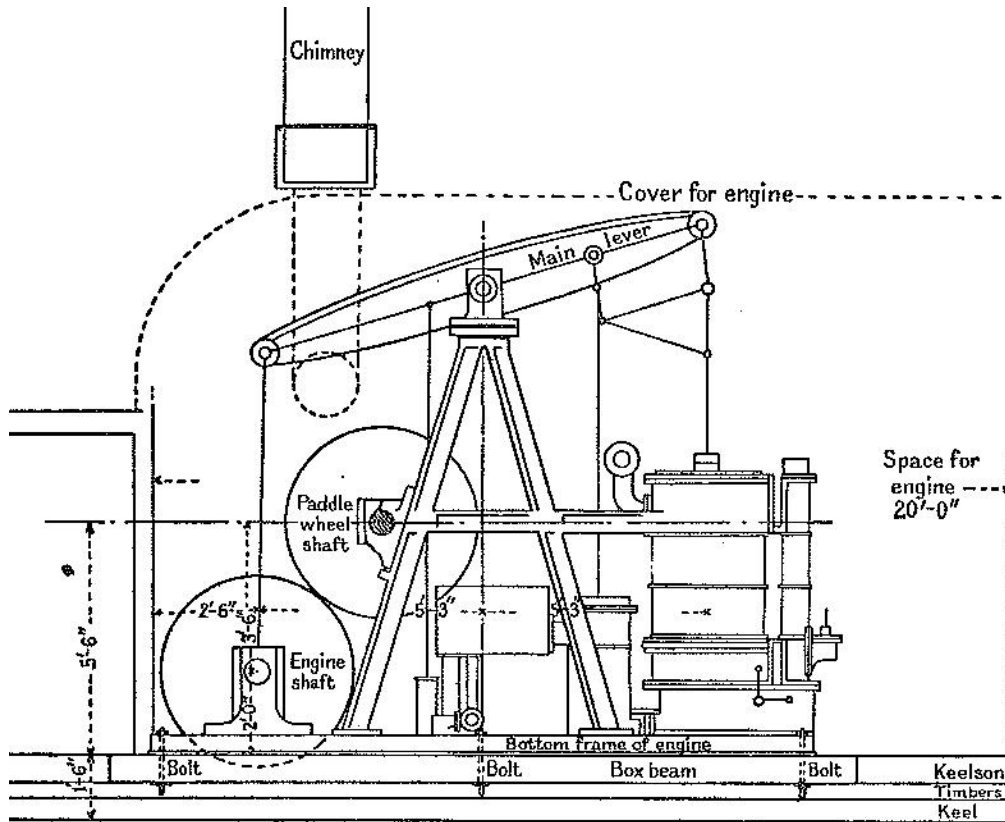

FIGURE II.3. Boulton and Watt 20-horsepower beam engine of HMS *Congo*, 1815 (Smith 1937:51; courtesy of Birmingham Reference Library, Birmingham, UK)

The large and very powerful paddlewheel frigates of the 1840s evolved directly from the small experimental auxiliaries of the 1820s like those vessels discussed above. The paddlewheel warship, despite eventually growing to tremendous size, was always limited by its exposed machinery and poor sailing qualities. While the machinery problem could be remedied to a certain extent, paddlewheelers always remained inefficient sailing vessels because of drag created by the wheels and the difficulty of arranging masts around the machinery spaces (Brown 1993:75). Sailing ships therefore remained the main force in the line of battle until the wide acceptance of the screw propeller, which allowed for acceptable sailing qualities in conjunction

with the advantages of steam power. Despite the known deficiencies of paddlwheelers, improvements were made, and the major navies continued to augment their inventories of steam warships, with the exception of the United States, which did not really begin serious steam frigate construction until the 1840s.

HMS *Cyclops* of 1838 was the first war vessel to be termed a steam frigate, and all large naval steamers after that retained the title (Lambert 1992:23). The term “frigate” implied a warship capable of serving as a cruiser or part of a battle line, but apparently there were never any serious proposals for a true paddle line-of-battle ship; this was probably due to an exaggerated fear of damage to the wheels (Brown 1990:71). Marine engines, the more correct source of unease regarding a paddlwheeler’s use in a battle line, had become smaller and more efficient. They were now considered powerful and reliable enough to drive large men-of-war, but prevented a full broadside from being carried on smaller vessels. The trend towards larger and larger paddlwheelers was thus begun in response to this problem. By 1845 HMS *Terrible* represented the peak of the trend as the largest paddlwheel warship ever built (Figure II.4). This vessel carried an excellent power plant and served honorably during the Crimean War (1853-1856). Unfortunately, like all paddlwheel frigates, the sailing rig provided for accompanying the fleet on long-distance cruising was only of limited value, being restricted in mast placement by the machinery. This was inherently true of all paddlwheelers, but it took some time to realize. The necessary compromise between sail and bulky machinery therefore limited the effective deployment of paddle warships as part of a mixed fleet (Lambert 1984:19).

France was always eager to match Britain in the development of steam warships, but during the 1830s to 1840s it remained reliant on British machinery. French paddle frigates were smaller than British vessels during this period, being used primarily as dispatch vessels. Some of

the more useful French steamers were *Phaeton* and *Meteore*, but both had unreliable machinery (Lambert 1992:26). French engineers were often quite creative in their quest to find a new strategy for steam that would trump the British, but no real success was achieved. France was finally forced to concede the weaknesses of the paddlewheel naval vessel some time after the British had done so.

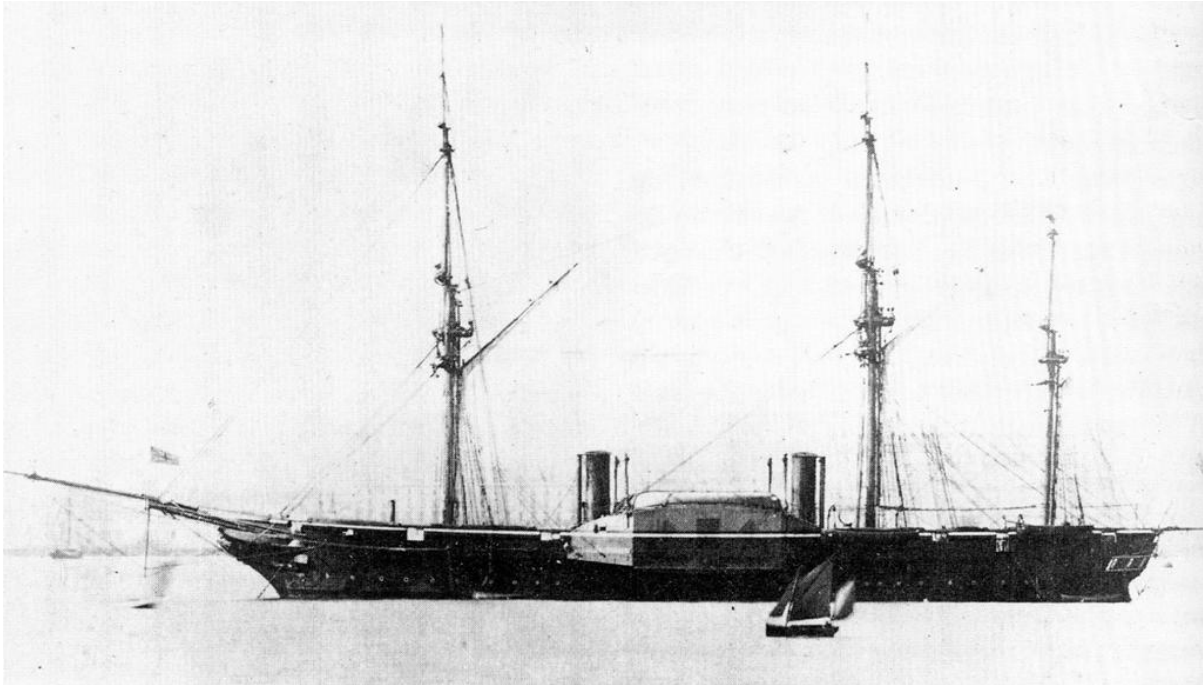

FIGURE II.4. HMS *Terrible*, world's largest steam warship when completed in 1845 (Lambert 1992:24; courtesy of Conway Maritime Press Ltd. 1992)

Developments in the United States followed those in Great Britain, while the rest of the world, even such powers as imperial Russia, showed little interest or initiative in employing steam warships during this period. After *Demologos*, no steam warships were built in America until 1835, with the completion of *Fulton II*. This vessel was not successful, although it carried as one of its crew the first-ever appointed Chief Engineer (Lambert 1992:27). No more steam paddle frigates were built until 1841, with the launch of the large and powerful *Mississippi* and *Missouri* (Figure II.5). These famous vessels served admirably during the Mexican War (1845-1848), and *Mississippi* also played a part in the Civil War. Despite their strength and reliability,

these two ships still represented all the weaknesses of the paddle frigate, namely, bad sailing qualities, inefficient fuel usage, and large machinery space. Only two more warships of this type were built in the U.S. by 1850. *Powhatan* and *Susquehanna* were larger and more powerful yet, but they were limited in coastal and river operations during the Civil War because of deep draft (Canney 1990:35). By that time, the U.S. Navy was concentrating on smaller sidewheel sloops and screw-propelled warships. The latter was on the verge of creating important changes in naval construction and tactics.

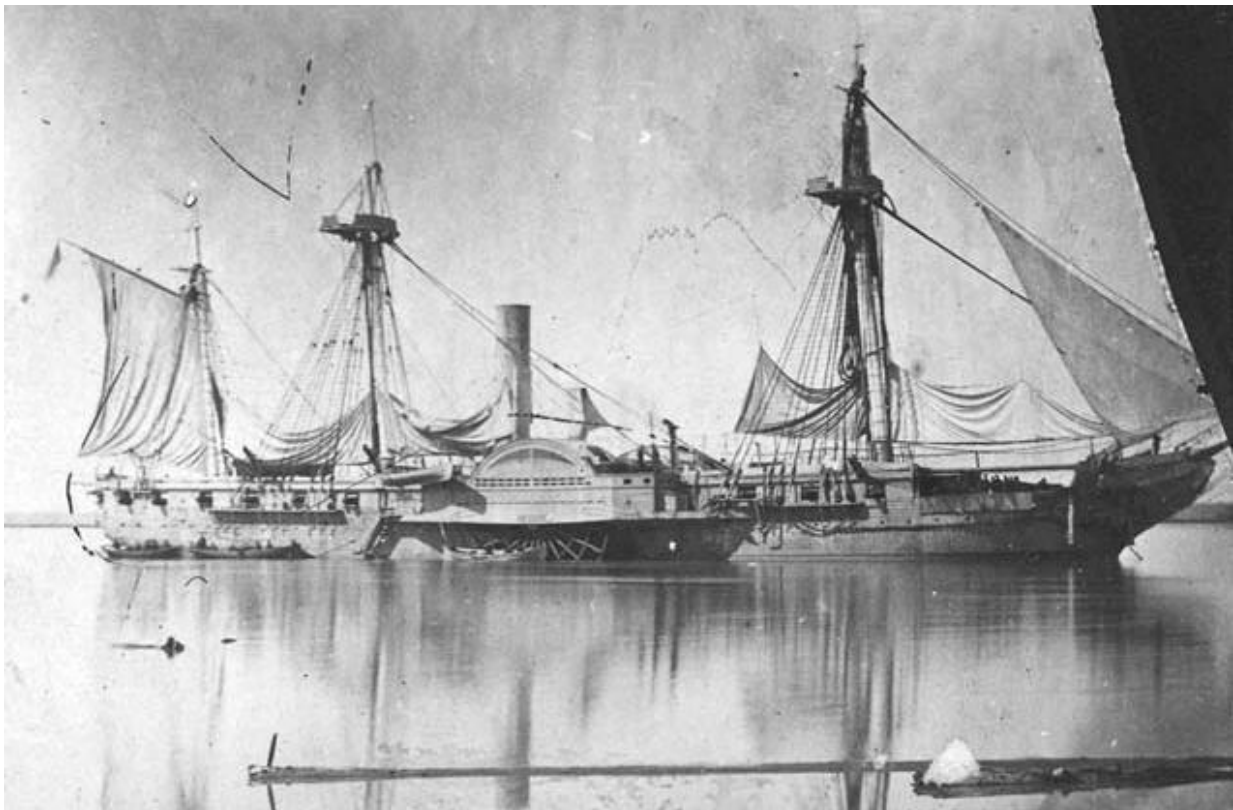

FIGURE II.5. USS *Mississippi* photographed during wartime service, about 1863 (Suydam Collection MSS 1394015, Louisiana State University 2012; photo by McPherson & Oliver, Baton Rouge)

The Screw-Propelled Warship

Edgar C. Smith (1937:64) neatly states the uncertain origins of arguably one humankind's most important inventions: "Though generally associated with the name of the great geometer, Archimedes, who lived in the third century B.C., we are told that the screw was

probably used...even before his time". Despite its ancient history, using this device to propel ships was a 19th century idea, although many inventors claimed the idea theirs. One work published in 1867 listed 470 names associated with the propeller's invention (Smith 1937:64). What is clear is that by the 1830s, the propeller had gained enough acceptance for extensive trials to be carried out.

Screw propulsion had been used on a British vessel, the government transport *Doncaster*, as far back as 1802. This system consisted of an outboard removable frame with the screw attached. It was powered by eight men walking around the capstan, and in this manner *Doncaster* made about 1.5 knots up and down Gibraltar Bay (Smith 1937:65). As interesting as this test was, it did not employ steam power and the propeller rig used remained a curiosity. Several similar experiments were apparently carried out in France and elsewhere, but there is little documentation concerning this. Propeller designs at the time were quite varied as many inventors submitted patents for new designs continually through the 1810s and 1820s.

The two most important men associated with the modern incarnation of the screw propeller were Francis Pettit Smith and John Ericsson. Smith's patent was submitted on 31 May 1836 and Ericsson's six weeks later (Smith 1937:67). Although their designs were different, as shown in Figures II.6 and II.7, each in its way showed great promise. Ericsson's propeller launch *Francis B. Ogden* successfully towed the Admiralty barge in the summer of 1837, demonstrating firsthand the power of even the early designs. After Ericsson departed for the United States in 1839, he continued his work, designing several screw-propelled vessels. One of these, USS *Monitor*, would ultimately bring him international fame during the Civil War and would result in a whole new type of warship. Back in Great Britain, the frigate HMS *Amphion* was the only warship to incorporate Ericsson's screw design (Lambert 1992:32).

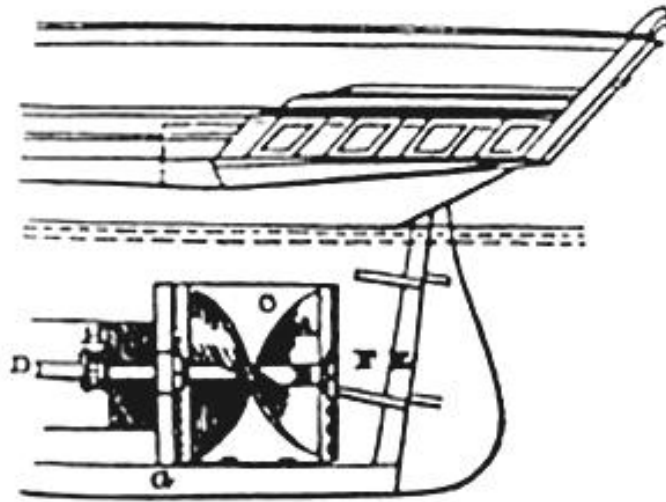

FIGURE II.6. Smith's screw propeller as equipped on *Archimedes*. It was originally designed with two turns of the thread, or blade, but was found to be more effective with just one. (The *Archimedes* Screw History Project 2012; from *The Journal of the Franklin Institute* 3 [7] 1844:90-94)

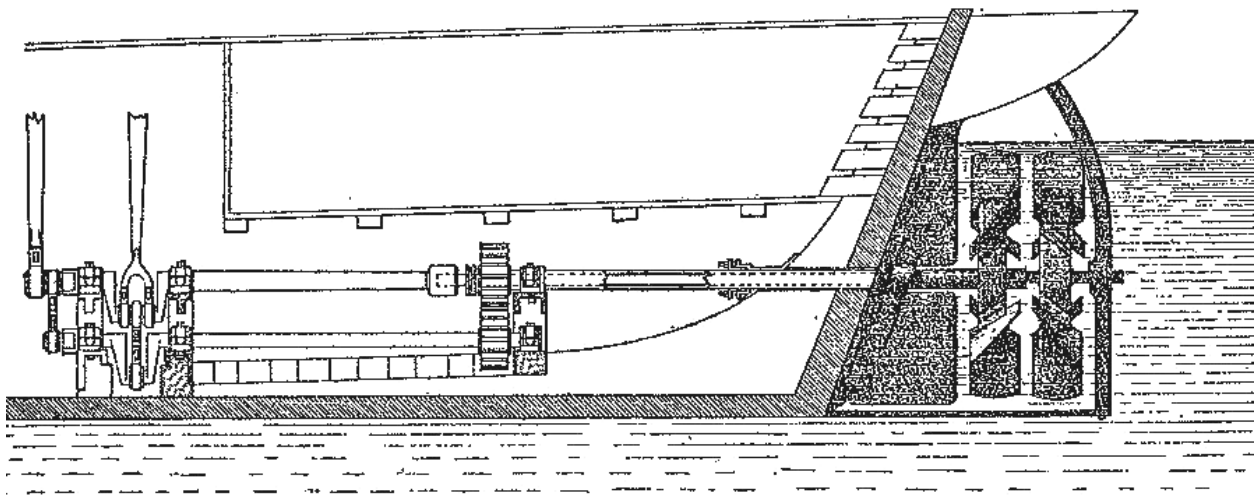

FIGURE II.7. Ericsson's screw propellers on *Robert F. Stockton*, 1838 (Smith 1937:67; from Woodcroft 1848)

Smith's propeller design was meanwhile incorporated into the screw sloop *Archimedes* of 1838 (Figure II.8). This small vessel was the world's first seagoing propeller-driven ship. Although its machinery was underpowered, *Archimedes* easily beat the cross-Channel paddlewheel packets during a series of speed trials and played a vital part in securing British naval interest in the screw (Lambert 1992:32). This paved the way for the first screw-propelled

naval vessels, *Rattler* for the Royal Navy, *Princeton* for the U.S. Navy, and *Le Napoléon* for the French Navy. Of these vessels, the first became somewhat of a celebrity.

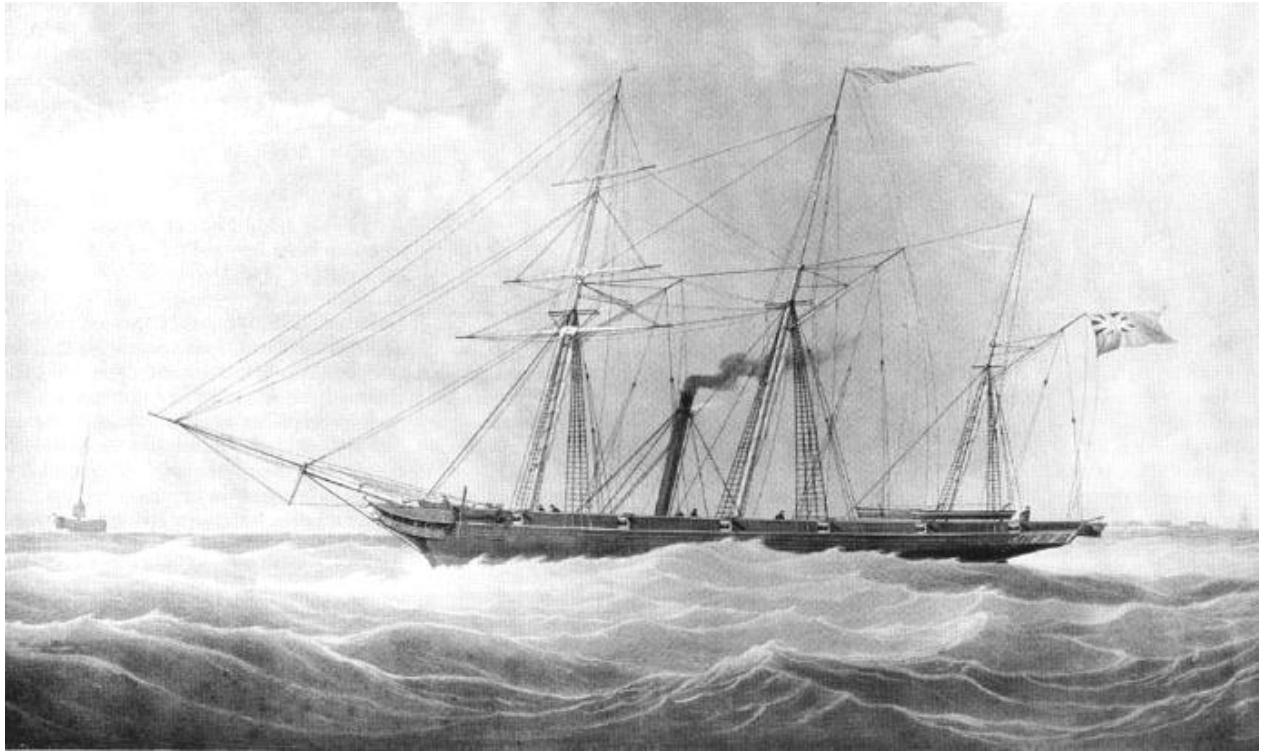

FIGURE II.8. Screw sloop *Archimedes* of 1838 (Brown 1990:103; courtesy of Science Museum)

HMS *Rattler* was originally designed as a paddlewheeler named *Ardent*, but was altered for screw propulsion while still on the stocks. The vessel was not finished until 1843, and extensive testing took place until 1845. In April of that year, the famous tug-of-war between *Rattler* and the paddlewheeler HMS *Alecto* took place. These two vessels had raced each other during previous trials, but were now lashed stern to stern. According to Smith (1937:73), “With the *Rattler*’s engines stopped, the *Alecto* was allowed to go full speed ahead, but on the *Rattler* going ahead the *Alecto* was brought to a standstill, and finally was towed astern at the rate of two miles and a half an hour...”. This demonstration is widely supposed to have influenced the Admiralty’s decision to fully support screw propulsion, but that agency was already well-aware of the propeller’s benefits. It must also be noted that *Rattler* was 60 tons heavier than *Alecto*,

with more powerful engines; therefore, "...the only thing proven was that a larger, more powerful ship can outrun and outpull a smaller, less powerful ship" (Rodgers 1996:32). In the end, this "test" had far more of an effect upon popular imagination than it did with naval policy (Figure II.9).

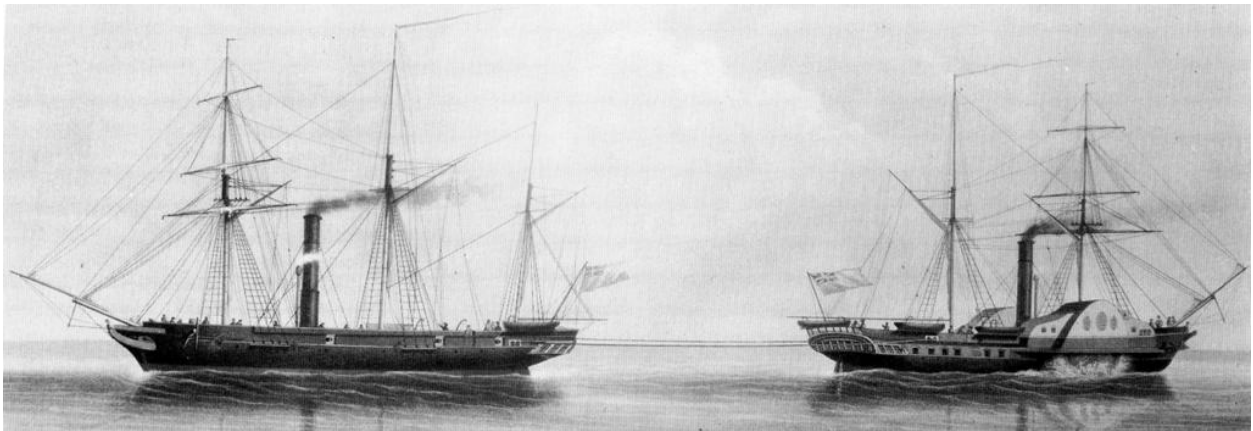

FIGURE II.9. The famous "tug-of-war" between the screw sloop HMS *Rattler* and the paddle sloop HMS *Alecto* in 1845 (Lambert 1992:30; courtesy of Science Museum)

As steam machinery for propelling vessels via screw grew in size and power, it became apparent that this new technology was ideal for warships. Unlike paddlewheel frigates, the machinery could remain in the hold, unexposed to combat damage and not taking up room on the gundecks. Also unlike paddlewheelers, the propulsion unit itself was completely underwater and protected during battle. Sailing qualities, still considered very important, were less affected by propellers as well. As these facts came to be appreciated, large warships, especially in Great Britain, began to be adapted to or constructed for screw propulsion.

The first large screw-driven warships of the Royal Navy were intended primarily as floating batteries, or blockships, of minimal steam power and reduced sailing rig (Brown 1990:122). These qualities were designed to make sailing between stations practical in all weather and also to avoid the use of tugs. As a result, the original vessels chosen for conversion, "...worn out hulks—were replaced by the more seaworthy ships eventually converted" (Lambert

1984:30). The 4 vessels chosen were originally “Armada class” 74-gunners: *Ajax*, *Blenheim*, *Edinburgh*, and *Hogue*. When *Ajax* was completed on 23 September 1846, it was the world’s first steam battleship (Brown 1990:122).

The British quickly began building many steam battleships of improved design after the success of the blockships. By 1850 the Royal Navy had at least 50 vessels of different types driven by propellers. Several of these vessels were old sailing ships converted to screw propulsion, while other battleships had been altered on the stocks to carry propellers, HMS *Agamemnon* being the first of these (Smith 1937:75). In the United States, Ericsson’s vessel USS *Princeton* proved very reliable and economical, serving well during the Mexican War, but remained the U.S. Navy’s only successful screw-propelled warship until the 1850s. French policy was, as always, to build fewer but better warships than the British, and they succeeded briefly with the 90-gun screw battleship *Le Napoléon* of 1850 (Figure II.10). A highly-successful design, eight sisters were built, but the British were, as always, able to improve upon and construct more vessels than the French.

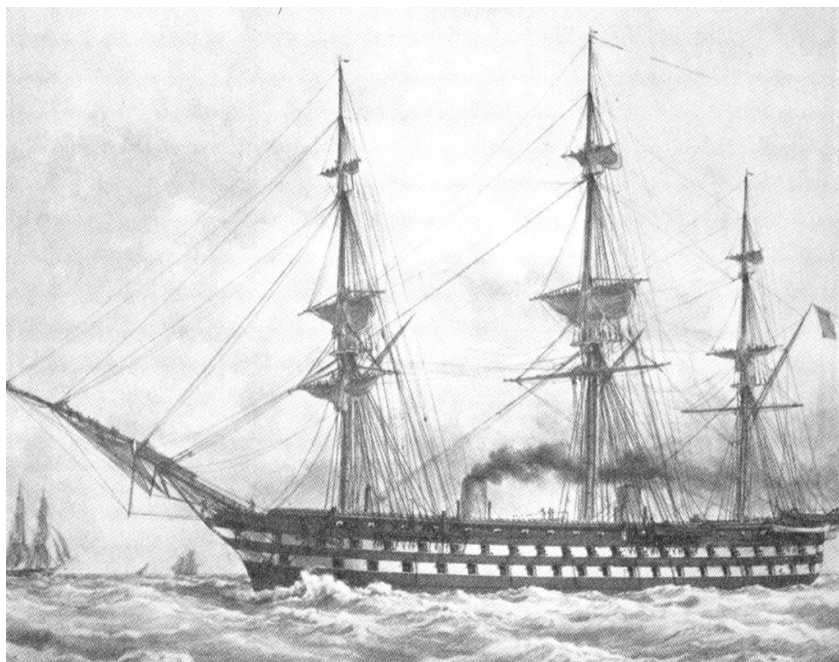

FIGURE II.10. French steam battleship *Le Napoléon* of 1850 (Lambert 1992:37)

While very powerful, the wooden steam battleships were simply an evolutionary step between the old sailing navy and the new iron and steam one. As theories of how best to employ propeller-driven warships stabilized, more and smaller screw warships were built, leading to large classes of steam sloops, corvettes, and frigates. The United States in particular pursued the development of the screw frigate. (Lambert 1984:114,117)

Frigates were always a desirable candidate for auxiliary steam due to their need for long-distance cruising and maneuvering in and out of foreign ports. They were also much less expensive to construct than battleships, and remained relevant on most stations. As a result, screw frigates were always more common than the battleship (Lambert 1992:42). Nations unable to compete with France and Great Britain in the building race, such as the United States and Russia, concentrated on building this type of vessel.

The United States Navy had a long history of building very large, powerful frigates that defied traditional classification. “Old Ironsides,” USS *Constitution*, that famous veteran of the War of 1812, is the most famous of these ships. In April 1854, a new round of large frigate construction began with the *Merrimack* class of screw steam frigate. *Merrimack* and its five sisters were very large and powerful, but their engines were too weak to propel them at more than eight knots (Figure II.11). Nevertheless, they created quite a stir in Europe, and the British responded with the even larger and more powerful *Mersey* and *Orlando* of 1858 (Lambert 1992:43). These vessels were structurally weak, and represented the limits of what a wooden hull could support without iron components. The case for iron warships was thus further advanced. *Mersey* and *Orlando* were, in fact, the direct ancestors of Great Britain’s first seagoing ironclad frigate, HMS *Warrior*. USS *Merrimack* had an unremarkable career as a frigate, but would go

down in history as the Confederate ironclad *Virginia* during the American Civil War. Therefore, the large steam screw frigates of the 1850s were the direct ancestors of the first ironclads.

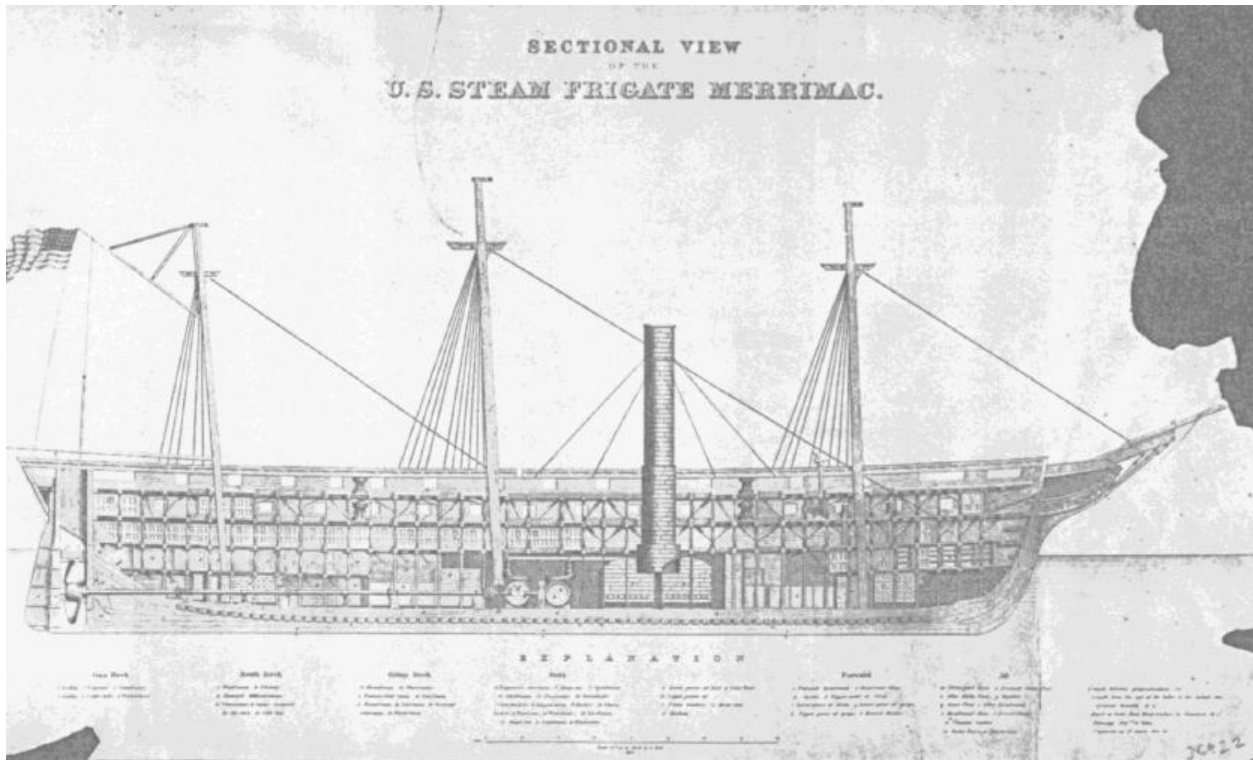

FIGURE II.11. A sectional view of *Merrimack*, showing machinery arrangement (Canney 1990:47; courtesy of National Archives)

A large number of other screw-propelled vessel types were constructed by the major navies during the 1850s. In the United States, a large number of wooden screw sloops were built. Among them were the *Brooklyn*-class sloops, of which Admiral David Farragut's flagship USS *Hartford* was a member. All of these vessels served with distinction during the Civil War.

With new battlefleet units being built of iron or ironclad, wooden screw battleships and other wooden warships became less popular, but did not immediately disappear from the lists. Wooden hulls were still more accepted, cheaper, and flexible than iron hulls, but the size of new warships was approaching the limits of the centuries-old technology of wooden shipbuilding. Iron bedplates and frames for engines and boilers put great stress in wooden hulls, and problems with propeller alignment were common due to wood's flexible nature. Nevertheless, wooden

cruisers continued to be built alongside iron and steel warships into the 1860s and 1870s (Lambert 1992:45). Like all tried-and-true technology, the wooden warship did not die away immediately, but gradually disappeared in the face of an immense technological revolution. The day of the screw-propelled, metal-hulled modern warship had come.

The Iron-Hulled Steam Warship

Coupled with the steam engine, the most important product of the Industrial Revolution was the large-scale production of iron, and later steel. This came at a time when, as has been seen, the size of wooden warships was nearing its limit, and new weapons and the need for supporting machinery necessitated a different construction material. In particular, the development of the shell gun by French army officer Henri-Joseph Paixhans in 1824 played an important part in the realization of metal-hulled and armored vessels. Paixhans's new weapon upset the delicate balance between the sailing ship's wooden walls and cannon firing solid shot that had existed for centuries (Holcombe 1993:2). The destructive power of shell against wood forced naval thinking towards armor-plated men-of-war, but employment of unarmored iron-hulled warships grew simply from iron's superior strength as a construction material.

Iron hulls were pioneered by merchant establishments, and as usual this fundamental change in ship construction first took place in Great Britain. Lambert (1992:47) states, "The first scientifically constructed iron vessel [was] the passenger barge *Vulcan*, built in 1819...". This vessel was built for service on the River Clyde in Scotland. Shipbuilders in this area and on the River Mersey became the pioneers of iron ship construction, away from the traditional shipbuilding centers of the Thames. Prior to the first orders for iron warships, a large number of iron merchantmen from these areas had been constructed and proven in service.

The first iron-hulled vessel to make a sea voyage was *Aaron Manby* of 1822. This small paddlewheeler had a successful career lasting into the 1850s. Many other vessels such as *Aglaia*, *Manchester*, and *Princess Royal* were constructed in the 1830s by such iron pioneers as Napier, Laird, and Fairbairn (Smith 1937:98-99). Perhaps representing the culmination of iron steamships during the period before 1860 was Isambard Kingdom Brunel's paddlewheeler *Great Western* of 1837 and the screw-propelled *Great Britain* of 1843. These vessels were intended exclusively for transatlantic passenger service, and the latter is preserved today as the first modern merchant vessel (Figure II.12). The success of these fine ships and others was closely watched by naval interests in Great Britain and elsewhere.

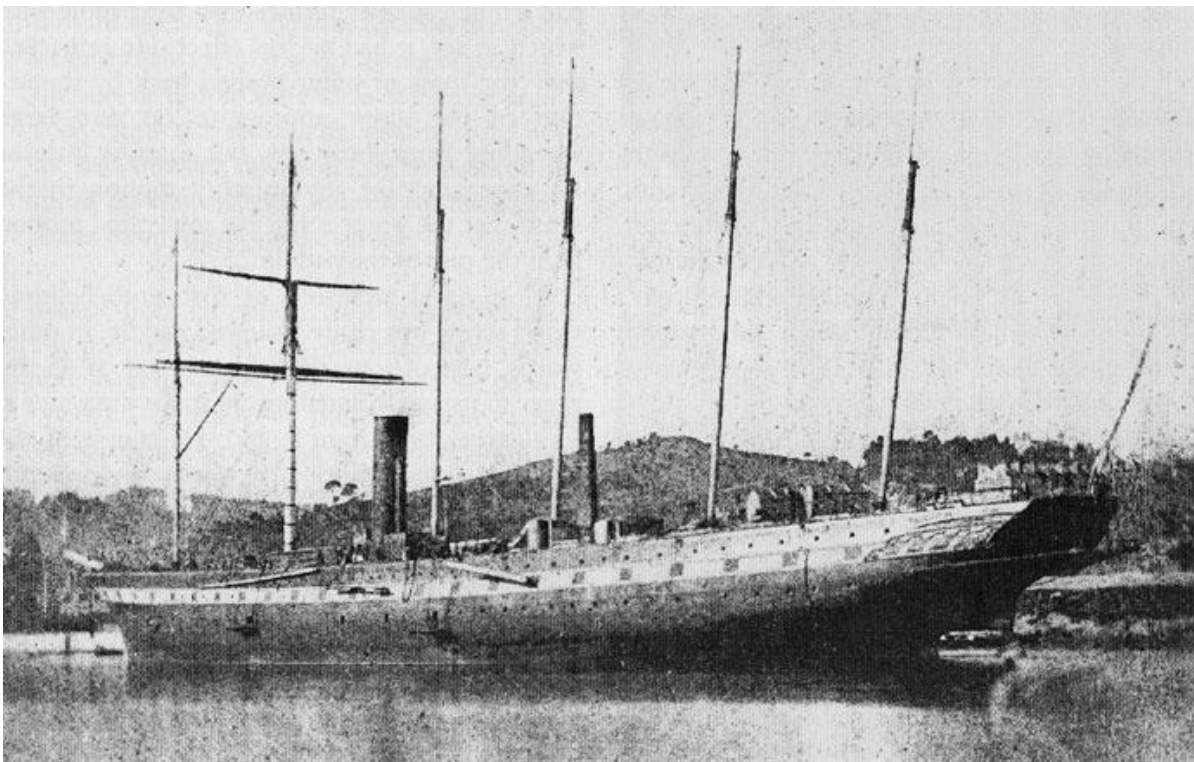

FIGURE II.12. SS *Great Britain*, considered the world's first modern ocean liner (Courtesy of John Speller 2012; photo by Henry Fox Talbot 1844)

Iron as a construction material allowed for larger vessels and a reliable foundation for improved machinery. As experience was gained with building ships of metal, rapid technological changes that have come to be representative of modern ship construction took place. Watertight

bulkheads were pioneered by Laird, and a large number of tests were performed that produced a system of corrections for compass deviation. The Royal Navy at first relied on private shipyards for these tests and others, and even ordered its first iron warships from civilian yards. The first of these vessels was *Nemesis* of 1840 (Figure II.13).

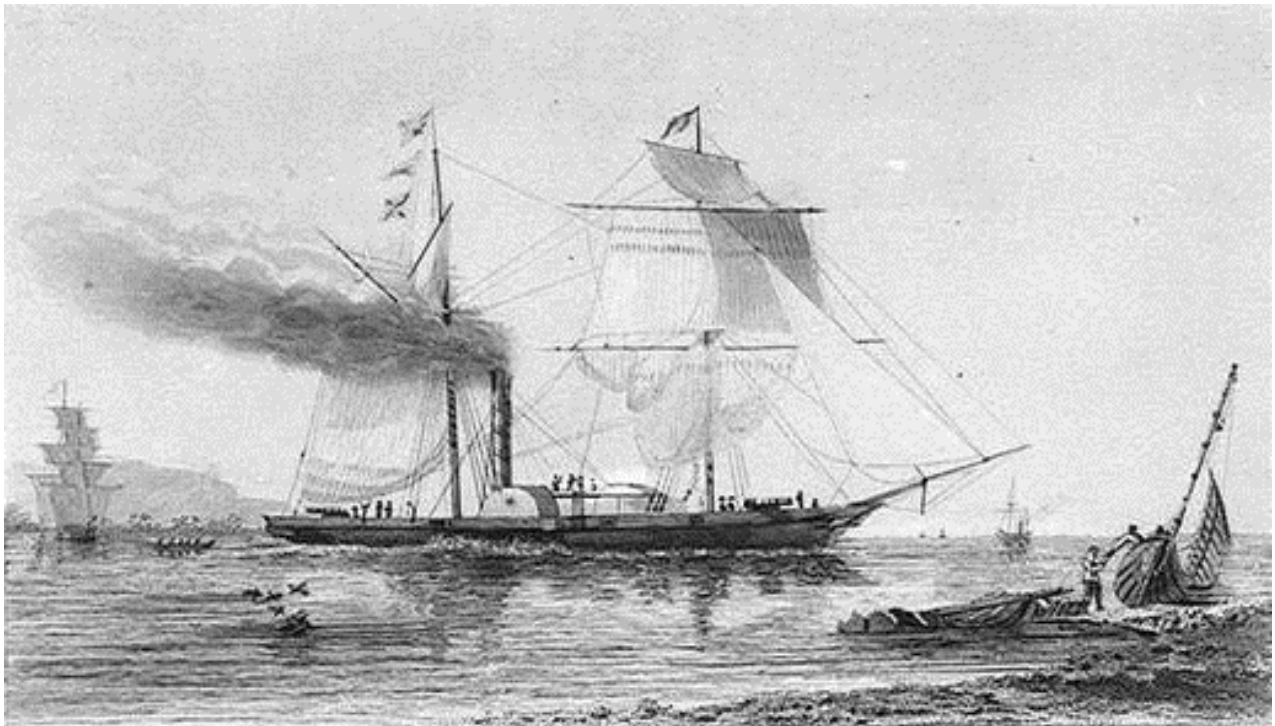

FIGURE II.13. *Nemesis*, world's first iron-hulled warship (National Maritime Museum, Greenwich, London, UK, 2012)

Nemesis was built by Laird's of Birkenhead under great secrecy, ostensibly for the East India Company, but in fact formed part of the British Squadron in China (Smith 1937:115). Laird's had by 1840 probably built more iron ships than any other firm. *Nemesis* was a paddle vessel, and went on to serve in a distinguished career, serving as the lead ship in the First Opium War (Lambert 1992:48). Following *Nemesis* were a large number of paddlewheel iron sloops such as *Guadeloupe*, *Phlegethon*, and *Mohawk*. The French in particular paid attention to these developments, but neither the French Navy nor the Royal Navy made overt moves to begin building iron warships in naval yards until the type was further proven.

The Royal Navy, in 1845, began an ambitious program of ordering large iron-hulled frigates, starting with HMS *Trident*. The four large vessels following this were *Birkenhead*, *Megaera*, *Simoom*, and *Vulcan*—the latter three were screw-propelled. Although strongly-built, all of these vessels were hastily downgraded to troopships prior to completion (Smith 1937:118). Concern over the results of firing trials caused this decision, as it appeared that wrought iron was much too brittle to stand up effectively against naval gunfire. In truth, the firing test results were largely ambiguous (Rodgers 1996:37). Nevertheless, these warships rendered valuable service, and *Megaera*, *Simoom*, and *Vulcan* participated effectively in the Crimean War.

During the period the British were constructing iron-hulled warships, the French and Americans built a few similar vessels. The French attempted to follow British practice beginning in 1837, but as usual were limited by inferior marine engineering facilities and a lack of expertise. The French program was originally designed to help bolster France's iron industries, but following the British lead, the iron warship program had largely ended by the late 1840s (Lambert 1992:49). Lingering concerns over iron's weakness under fire and rapid fouling problems prevented for a time the further development of iron warships in Europe. For this reason it was the composite ironclad warship that revolutionized naval warfare in the 1860s.

The only successful iron-hulled war vessel constructed in the United States before the Civil War was the paddle frigate USS *Michigan*, ordered in 1842 (Figure II.14). At this time no yards in America had yet produced an iron seagoing vessel, looking primarily to Britain for expertise and materials. *Michigan*'s design as such was largely based off *Nemesis* (Rodgers 1996:20). Intended for Great Lakes service, *Michigan* enjoyed all the benefits of serving on cold freshwater, having a working life of 80 years. During this time span, the iron-hulled warship's counterpart, the ironclad, subsequently proved its superior strength in battle.

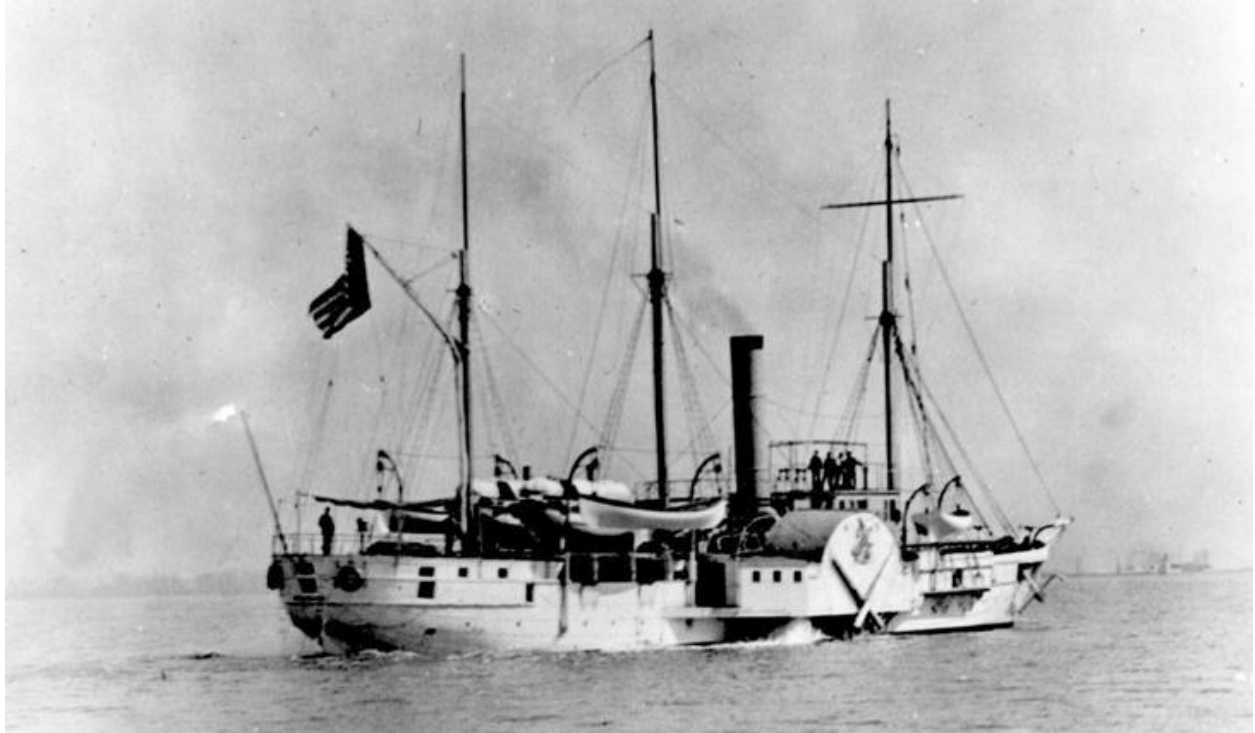

FIGURE II.14. The iron paddle frigate USS *Michigan*, launched in 1844, went on to serve for 80 years. (The Archimedes Screw History Project 2012)

The Armor-Plated Steam Warship

Like the other innovations discussed in this chapter, the concept of armoring warships dated back far beyond the 19th century, but was not truly realized until then. The first well-documented armored warships were the “turtle ships” of Korean admiral Yi Sun-sin in the 1590s. These were used to repel a Japanese invasion, but their armor was primarily for the protection of the crew, not the ship (Lambert 1992:50). In the centuries between 1590 and 1859, many proposals towards protecting ships with armor were put forward, but little is known about them. “Prior to the second quarter of the 19th century there existed neither the incentive nor the technology to produce viable armored warships” (Holcombe 1993:2). Cannon fire was usually unable to significantly penetrate the wooden walls of the fleets. As has been previously discussed, it was the invention of the shell gun in 1824 by Paixhans that led to the first serious considerations for armoring modern war vessels.

During the 1840s, construction of a purpose-designed ironclad began in America. A wealthy industrialist and shipbuilder from Hoboken, New Jersey, James Stevens, had received from Congress an appropriation of \$250,000 to construct what was probably the first ironclad ordered for any navy (Durkin 1954:63). The vessel came to be called the “Stevens Battery,” but was never finished due to constant design changes and lack of funds. Construction finally came to a stop in 1853, just as Europe was beginning to recognize the need for such a vessel. Stevens lobbied for more funds, but was largely rebuked in Congress; one Senator, future Confederate Secretary of the Navy Stephen R. Mallory, supported him. Ultimately, the project was allowed to limp along until 1881, when the Stevens Battery was finally broken up on the ways. In the course of its construction this remarkable vessel was altered from a length of 250 feet with one propeller and 4.5-inch armor to a length of 415 feet with massive engines driving two propellers and 6.75-inch armor (Lambert 1992:51). If it had been completed, the Stevens Battery would have been the world’s largest and most powerful warship; there seems little doubt of its potential influence on future ironclad construction.

There were no major wars involving the new naval technologies of steam power and shell guns combined until the Crimean War. It began in 1853 at the Battle of Sinope, where the Russians employed shell guns with devastating effect against a Turkish squadron of wooden warships. The British and French allied themselves with Turkey against Russia and in 1854 declared war. Russian fortifications and naval forces in the Black Sea were therefore targeted. At Sevastopol in particular, the Russian guns again proved the strength of shell against wood. This British-French defeat, coupled with lessons learned from Sinope, led to the first combat use of armored vessels in modern naval warfare (Holcombe 1993:2-3). France, with its smaller navy,

quickly sought a method of invulnerability for its warships, and settled upon the tried-and-true floating battery concept.

Dévastation, *Lave*, and *Tonnante* were accordingly completed in 1855 (Figure II.15). These ungainly vessels were driven by sail and steam, but could not move efficiently on their own, echoing the motive power of 40 years before. Andrew Lambert (1992:51) reinforces the point: “Just as steam came to naval use in a floating battery (*Demologos*) so armour was first applied to a similar type”. Protected by 4.5-inch armor, these vessels were intended to be anchored in front of coastal forts and reduce them. They did just that at the Battle of Kinburn on 17 October 1855, leading to widespread acclaim of the ironclad’s merits.

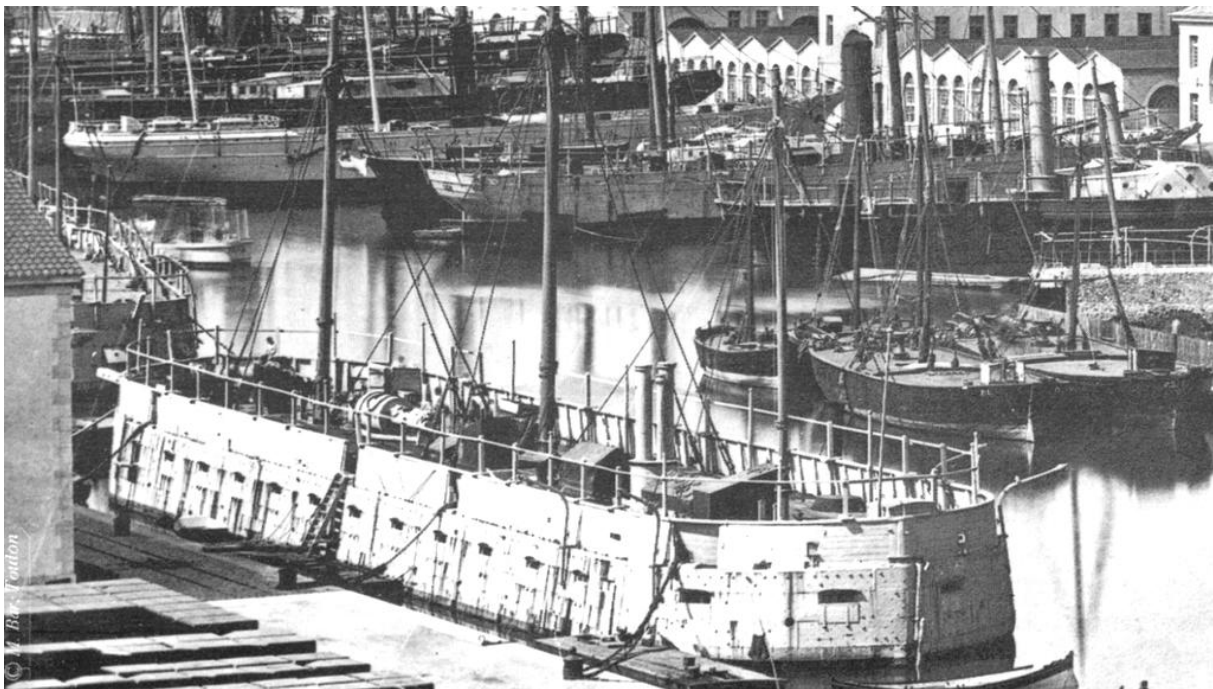

FIGURE II.15. The French ironclad floating battery *Dévastation* was used to great effect at the Battle of Kinburn during the Crimean War. (Lambert 1992:51; courtesy of Marius Bar)

Closely following the French in pressing ironclad floating batteries into service were the British, who took extra time to refine the design and make it more ship-like, as seen in Figure II.16. The first British ironclads were *Glatton* and *Meteor*, followed later by *Aetna*, *Erebus*, and *Terror*. *Aetna* was destroyed by fire prior to completion, but the others lived out their war service

without seeing action (Lambert 1992:52). These vessels were well-constructed, but as floating batteries they did not point the way forward. After the conclusion of hostilities in 1856 it was the French who first sought to pioneer the development of the ironclad cruiser.

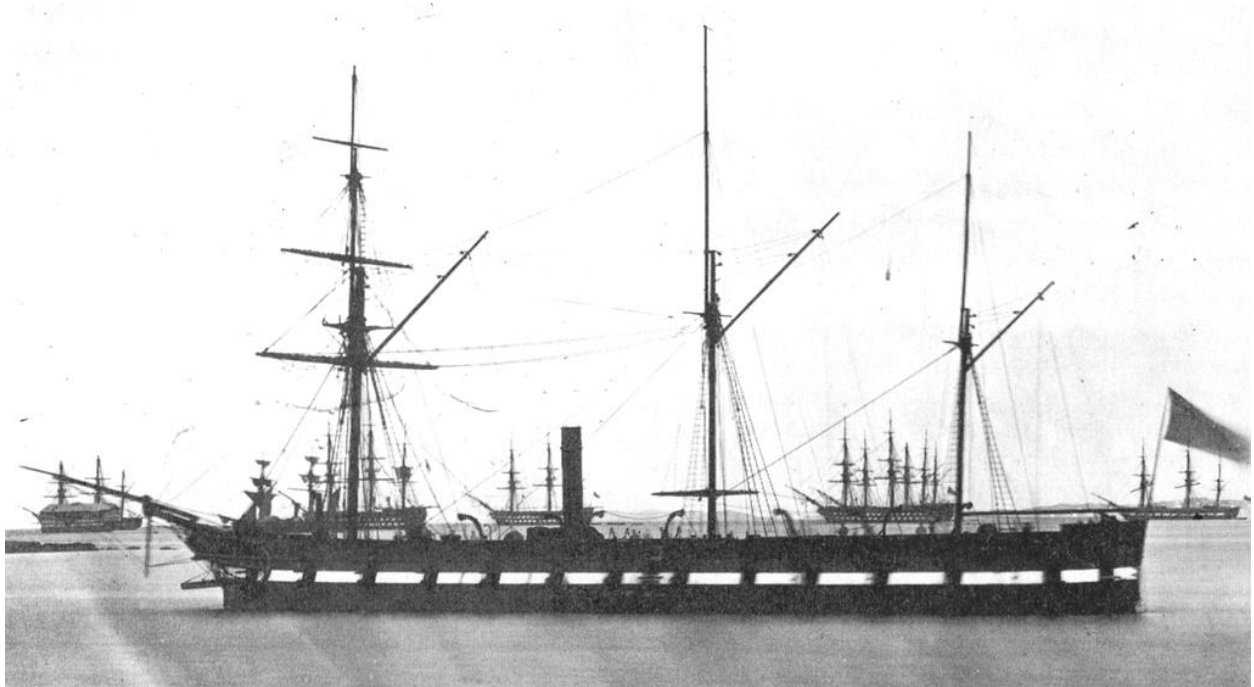

FIGURE II.16. British ironclad floating battery HMS *Terror* at Bermuda during the American Civil War (Lambert 1992:53; courtesy of National Maritime Museum)

Accordingly, in 1859 warship technology took another leap forward with the completion of the French ironclad frigate *La Gloire* (Figures II.17 and II.18). This powerful warship was essentially a cut-down version of a wooden screw battleship fitted with four-inch armor. Despite the stir caused in Europe by *La Gloire*'s debut, the ship suffered from serious weaknesses, including poor seakeeping qualities and weak engines. Its career was short and unremarkable, as wooden hulled seagoing ironclads "...were not a healthy type..." (Lambert 1992:53). *La Gloire* did inspire the British to ironclad construction and thus initiated a new naval arms race.

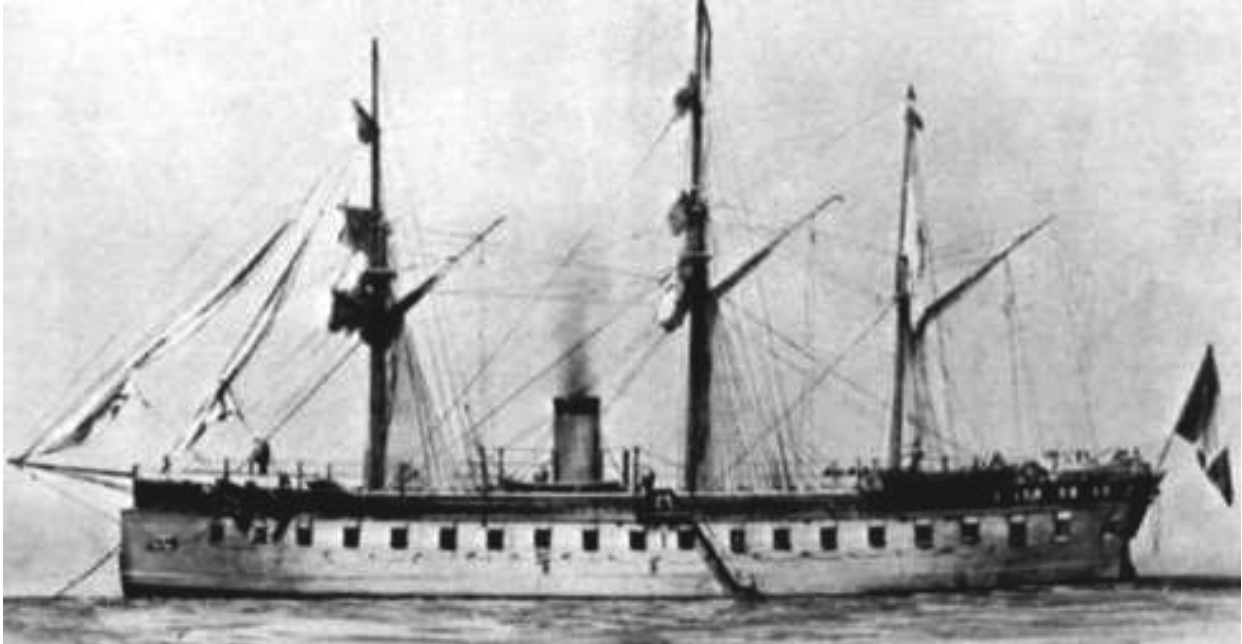

FIGURE II.17. *La Gloire*, laid down 1859, was the world's first seagoing ironclad frigate. (Courtesy of Larry Neilson 2012)

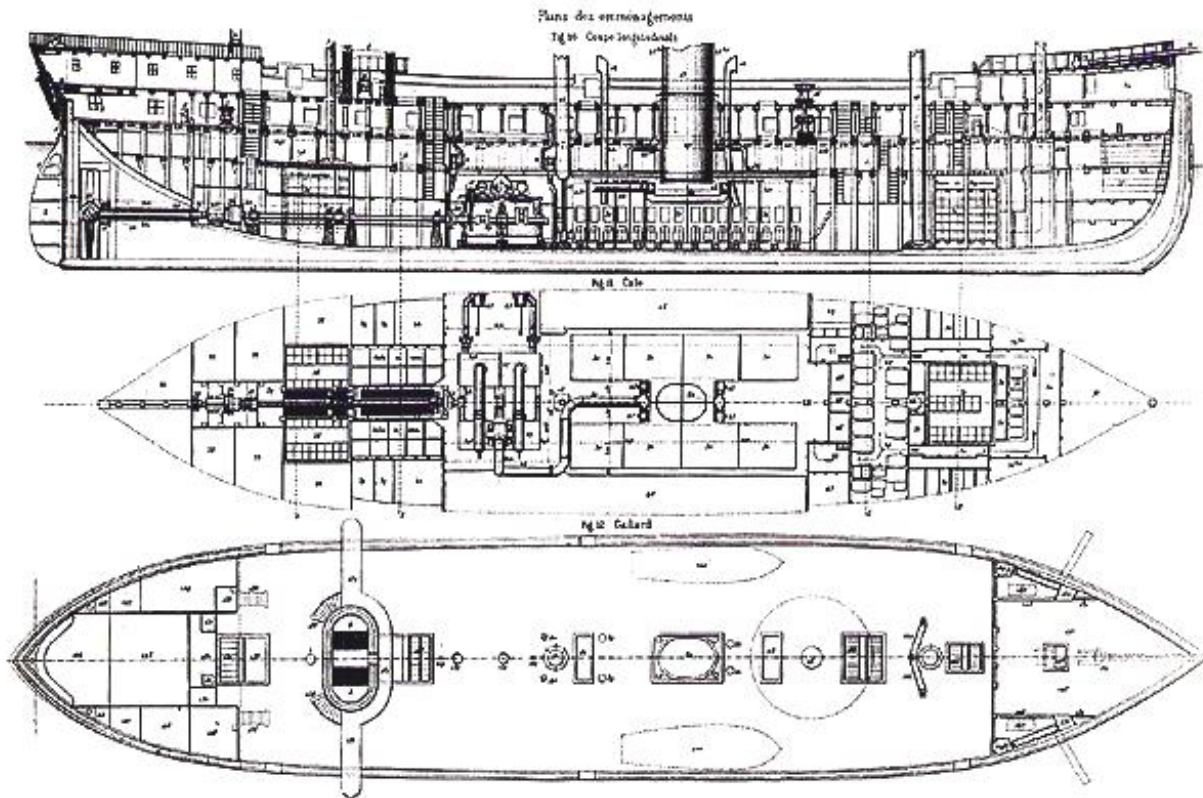

FIGURE II.18. Longitudinal cutaway and deck plans of *La Gloire*, showing machinery (Courtesy of Larry Neilson 2012)

Great Britain entered the new naval race strongly with the impressive HMS *Warrior*, completed in 1860. This large 400-foot vessel had an iron hull with 4.5-inch armor and was capable of 13.5 knots, fitted with the largest marine engines of the day (Figures II.19 and II.20). *Warrior* was essentially an enlarged and improved version of the steam frigates *Mersey* and *Orlando*, but was far more powerful than any ship afloat when completed. Considered to be the first truly modern warship, the first British ironclad “...would have been in no danger from any combination of wooden ships, and would have had little trouble with *Gloire*” (Lambert 1992:56). In one well-executed move, the British had regained the lead in the naval race.

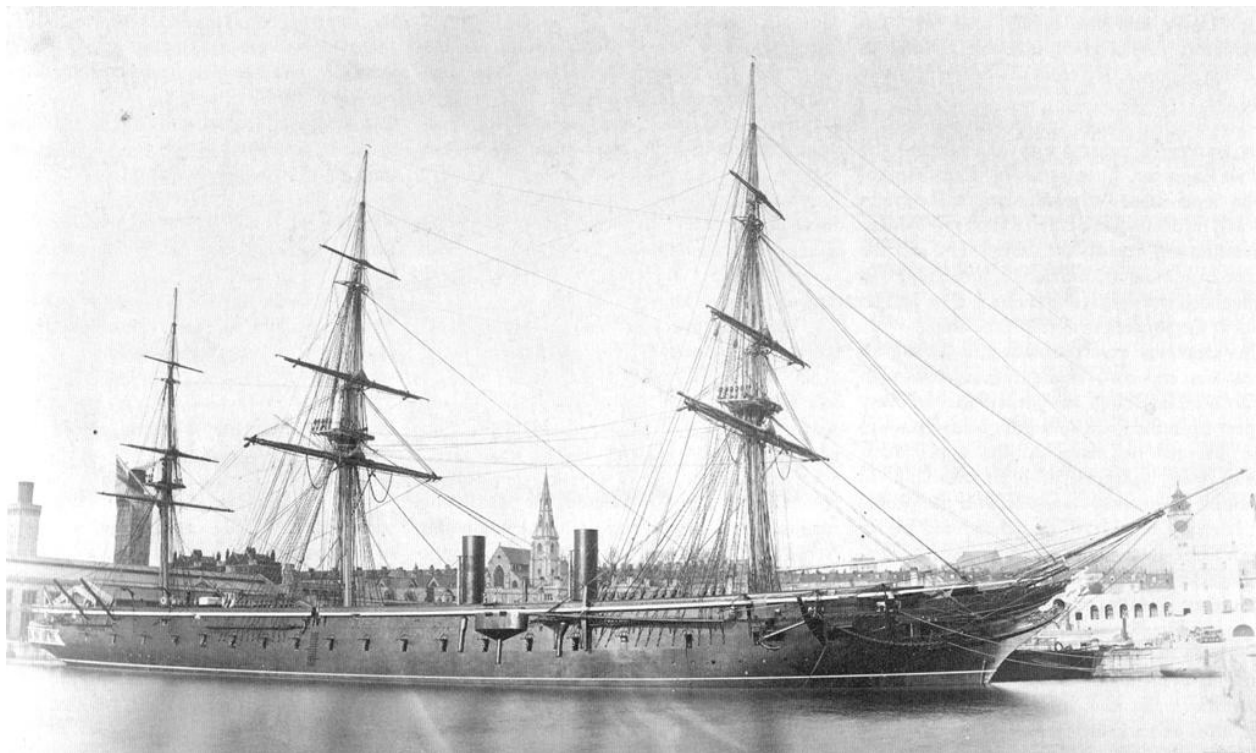

FIGURE II.19. HMS *Warrior* (Lambert 1992:55)

In the years leading up to and during the American Civil War, many more ironclads were built, each class attempting to improve upon the excellent example set by *Warrior*. This trend culminated in the 1860s with the huge *Minotaur* class of 36 guns. The abundance of ironclad vessels in Great Britain and France during this time was matched only by those built for wartime

service in the United and Confederate states during the Civil War. In 1862 alone, approximately 88 ironclads of various types had been built or were building in Britain and France (Baxter 1933: 209). The future of warfare at sea was now fully committed to the naval-industrial complex.

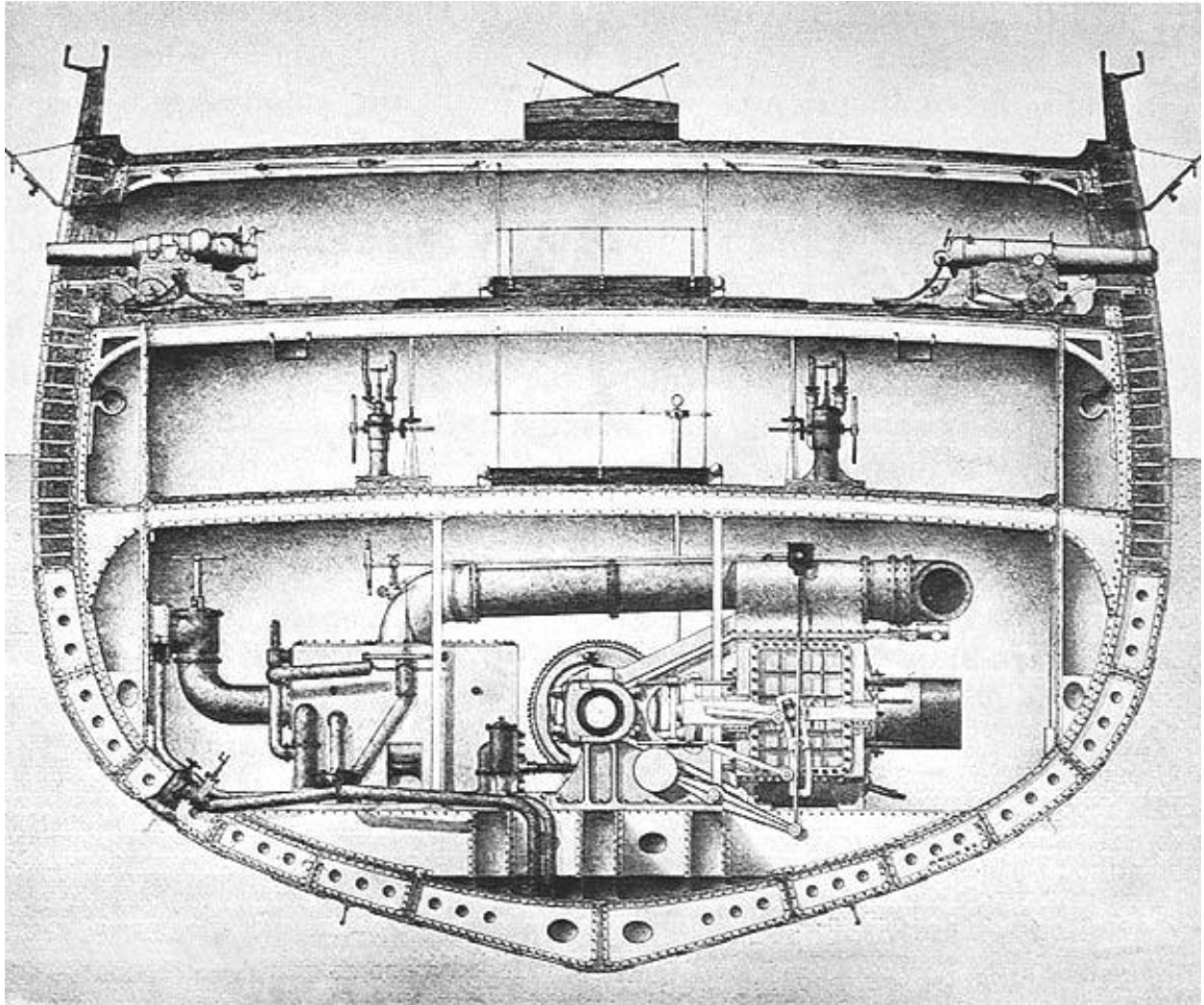

FIGURE II.20. Section through *Warrior*'s engine room showing Penn trunk engine—the largest of the time. *Warrior* had two of these, capable of propelling the ship at 12-13 knots without the use of sails. (Brown 1990:183; courtesy of Science Museum)

A keen observer of the revolutionary naval changes taking place in Europe during the 1850s was Senator Stephen Mallory of Florida, already mentioned as the future Confederate Naval Secretary. At this time he was chair of the U.S. Senate's powerful Naval Affairs Committee (Holcombe 1993:6). It was Mallory's business to keep track of any promising new

naval technology; he especially continued to advocate the adoption of ironclads and the construction of other modern steam warships. Mallory also worked towards disciplinary reforms and more efficient disposition of naval personnel. As Robert Holcombe (1993:6) states,

Thus when empowered to produce a navy for the fledgling Confederacy in early 1861, Mallory's appreciation of naval innovations in progress, and the industrial liabilities that prevented the South from rapidly building a conventional fleet, led him to consider the construction of ironclad warships a priority.

The Confederate ironclad program, and indeed its entire naval effort, came to hinge upon industrial capacity. Those penultimate products of the Industrial Revolution, the steam engine and mass-produced iron, were still scarce in the agrarian South by 1861. As Confederate industry developed, Mallory's policy saw more success in building and armoring vessels, but effective propulsion systems too often remained out of reach. Although the armored steam-powered warship had come of age by 1860, the technology to build quality engines still rested primarily in Europe and the Northern states. There were several types of steam engine uniquely American in design, but ideas were regularly exchanged back and forth across the Atlantic. As a result, marine steam engines employed in the United States on the eve of the Civil War were as varied as anywhere else in the world.

CHAPTER 3: STEAM MACHINERY TYPES IN AMERICA, 1800-1860

By the 1860s, the industrialized world had seen an explosion in types of steam machinery being produced for vessels of every description. New ideas were continually put forth and improved and new designs manufactured as the technology continued to advance. In Great Britain, the large iron and steel shipbuilding firms competed with each other in producing more powerful and effective engine and boiler designs. Much of this energy was directed towards new, compact systems for screw-propelled warships. Paddlewheel-driven vessels also continued to be built, especially on the Mississippi River system of the United States.

The United States was probably second in industrial capacity behind Great Britain during the 1850s, although France was always a close contender as well. Steam engine development in the U.S. was mostly driven by mercantile interests. Prior to the Civil War the U.S. Navy was small and did not have many steam warships. While the large companies in Britain such as Laird's received many government contracts for naval steam engines, many U.S. companies such as the Tredegar Iron Works in Richmond, Virginia, only occasionally built steam engines or their components in addition to other work. By the late 1850s this had begun to change, especially in the North, but as a whole the American marine steam machinery business lagged significantly behind that of Britain. Often, American-built or designed engines differed considerably from their European counterparts. A few distinctively American styles emerged and came to be used onboard several of the Confederate ironclads. This chapter will, therefore, examine the development and variety of steam engines in the United States, as well as the exchange of ideas across the Atlantic. (Tomblin 1988:1-8)

It has already been seen how the marine steam engine was first applied to navigation and military use in Europe and the United States at the beginning of the 19th century. By the start of

the Civil War in 1861, this technology had matured to a considerable extent. Manufacturers and officials of the British Royal Navy had begun to attempt some degree of standardization in vessel propulsion systems, but during the 1850s and 1860s a large amount of variation still existed. Many vessels were still powered solely by sail, others utilized the tried-and-true paddlewheel, newer vessels had screw propulsion, and still others utilized a combination of all three methods. Many different engines were developed that were thought to be most effective, but only a few major types gained widespread recognition and usage. In the United States, the preferred engine types often differed from those in Great Britain and France. (Atherton 1851:28-33; Foster 1986:67-70)

In the years leading up to the Civil War, beginning in the 1840s, the U.S. Navy and that of France took the lead in adopting steam technology for warships (Baxter 1933:3-4). As paddlewheels were still the only well-tried way of moving a ship by steam until the 1840s, the Navy utilized paddle frigates, beginning with USS *Mississippi* and *Missouri*. The U.S. trend continued with steam screw sloops and frigates built beginning in the 1850s with USS *Merrimack*. Like the other navies, the U.S. Navy was cautious in its approach to adopting the new technology completely, particularly after experiments with the horizontal underwater “Hunter wheel” ended in spectacular failure (Rodgers 1996:34). All of the new vessels were accordingly fitted with masts and yards. This practice would continue for many years, although most of the Civil War ironclads were driven by steam alone. The U.S. Navy also followed the practice of the Royal Navy in relying on private works to construct steam machinery. Until the large-scale adoption of iron shipbuilding, “...most wooden naval steamers in the United States were built in government shipyards and their engines and boilers in private engine works...” (Tomblin 1988:284). This practice resulted in few vessels with power plants designed by naval

engineers until the Civil War, but plenty of experience was gained in testing and utilizing steam systems by that time.

In April 1861, the United States Navy had in its possession "...seven screw frigates, five screw sloops, four sidewheel sloops, and eight gunboats for a total of 24 steam-powered vessels" (Tomblin 1988:254). During the war, the number of steam warships would increase exponentially as both sides frantically initiated new construction and converted merchant vessels to naval service. A wide range of engine types thus fell under naval operation, both Union and Confederate. Most had their origins in merchant service, and were not ideally suited for warships. Nevertheless, several of these came to be utilized onboard Confederate ironclads.

Engines for Paddlewheel Propulsion

Paddlewheel engines were fully developed by the time of the first effective application of screw propellers. There were many different ways to effectively transmit the engine's power to the main shaft, but the ideal arrangement of paddlewheel engines was quite different from that needed for screws. First, "All engines for driving paddle wheels necessarily revolved at slow speeds..." (Smith 1937:145). A long piston stroke was recognized as being most efficient for turning wheels, as compared to short, fast piston strokes for propellers. Second, the whole arrangement of paddlewheel machinery was quite bulky and seemingly exposed—not desirable features in a fighting ship, although coal bunkers usually protected both boilers and engines. Arrangement of the engines was restricted by the athwartships nature of the main wheel shaft, which also prevented the mounting of broadside guns (Rodgers 1996:31). The search for a suitable and simple arrangement for maintenance led to some very tall engines, often causing top-heaviness. Most steam engines had to be placed either directly above or below the main shaft in the center of the vessel, leading to both a high center of gravity and sagging problems in

vessels with heavier engines. Inclined engines were a largely-successful attempt to remedy these issues; a particularly fine example of this system was that onboard the iron sidewheel frigate USS *Michigan* (Rodgers 1996:28).

Merchant vessels did not have the same concerns as warships, and paddlewheel-driven vessels continued to thrive on American rivers until the early 20th century. Many different engines were tried in the period between 1800 and the Civil War: “There was no orderly development of a perfect engine, but an explosion of efforts in many directions” (Foster 1986:67). While most of these experiments were unsuccessful, a small number of engine types became widely adopted for one reason or another. Foremost among these were the “crosshead,” “walking beam,” “oscillating,” and “direct-acting” types. These became staples of American and British merchant steam power. There were other successful early engine types developed in Britain, such as “Siamese,” “Gorgon,” and “grasshopper” engines. These did not see common use in the United States, but some vessels, including naval units, employed these designs.

Crosshead engines were the first type to see widespread usage in America. These had been developed directly from Boulton and Watt’s beam engines of the 1780s. Steamboat pioneer Robert Fulton was the first to use this system on shipboard in 1807, but it was complicated by gearing to a large flywheel. The type was soon simplified to the form it would keep until the 1840s, when crosshead engines were phased out in favor of more efficient layouts (Foster 1986:67). In its heyday, the crosshead engine epitomized the simplicity and practicality sought by most private enterprises. A typical arrangement is shown in Figure III.1. The steam cylinder or cylinders were placed vertically over the main shaft, supported by a frame, usually wooden, of appropriate size. A large horizontal beam called the crosshead was moved up and down in frame guides by the stroke of the piston rod, transmitting the engine’s energy to a connecting rod that

turned a crank shaft on each side of the cylinder. This arrangement allowed for ease of access and relatively smooth operation, but it was handicapped by the placement of so much weight high above the waterline. As steamboats got larger, a practical limit of engine size was reached due to balance issues (Foster 1986:67). A similarly effective engine needed to be utilized that would not disturb vessel stability.

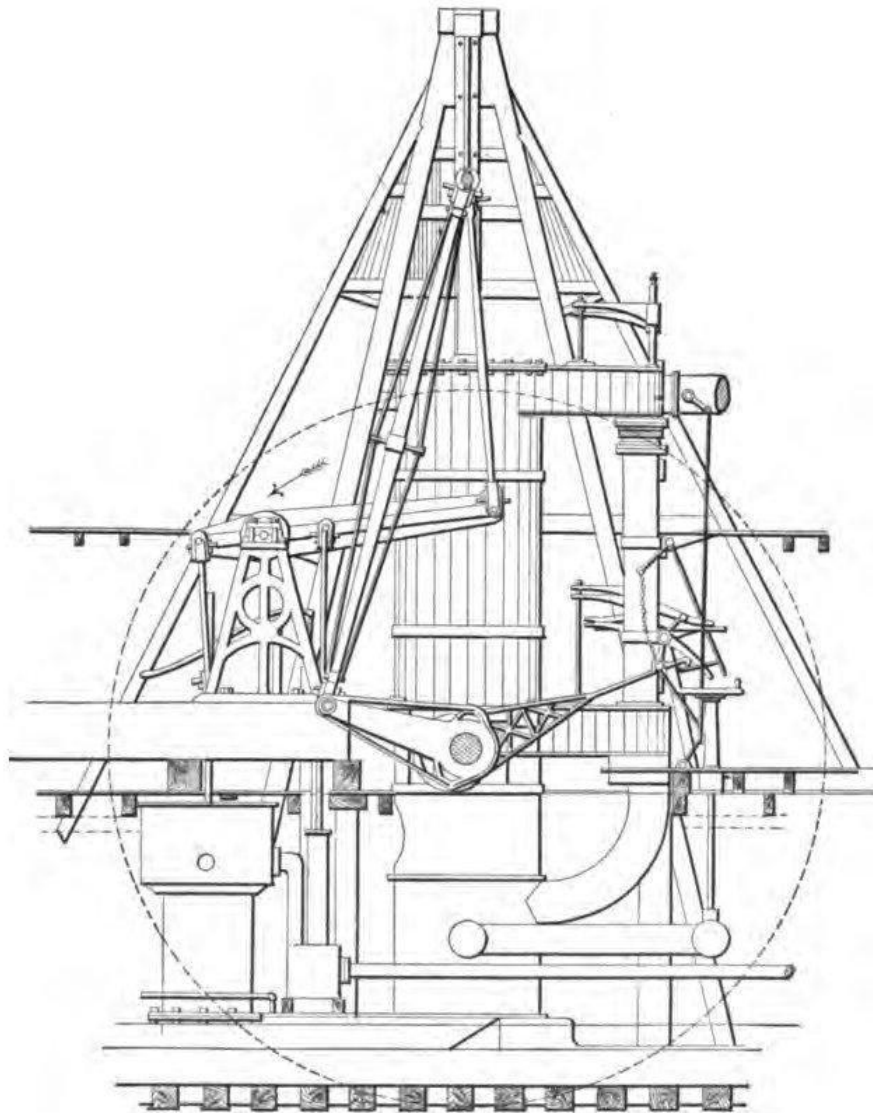

FIGURE III.1. Typical crosshead engine, with paddlewheel outlined (Hutton 1897:25)

Walking beam engines, sometime called “vertical beam,” solved many of the problems encountered with simple crosshead engines. Many paddle steamers came to use this arrangement,

particularly those vessels used in coastal trade, the Great Lakes, and the East Coast. The walking beam setup involved a vertically-placed cylinder, but it was placed in front of or behind the main shaft. Movement of the piston raised and lowered one end of a beam pivoted on its center on top of a large frame. The other end of the beam moved a connecting rod that turned the paddlewheel crankshaft. Figure III.2 shows a complete diagram of this interesting machinery arrangement.

(Foster 1986:67)

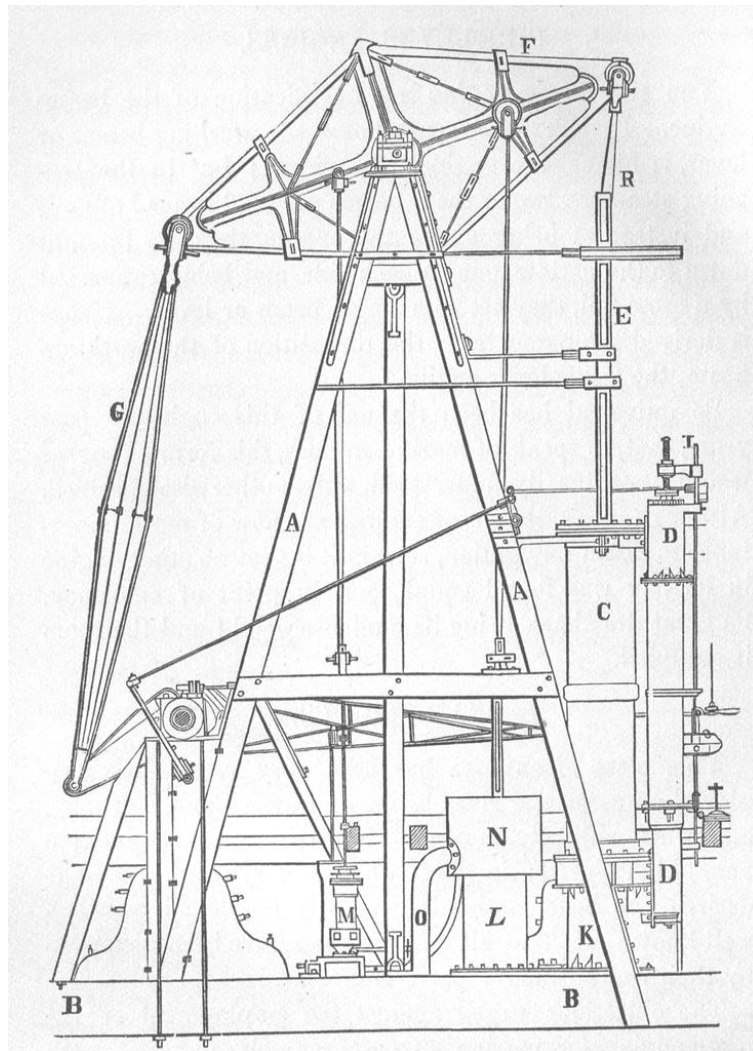

FIGURE III.2. Typical walking beam engine (Roper 1897:210)

The walking beam engine remained a popular type in American merchant paddlewheelers into the 1920s. It was simple and easily accessible, and had a lower center of gravity than the

crosshead type. The name “walking beam” came from this engine’s easily-observed mode of operation due to its moving parts being exposed above a vessel’s decks, as in Figure III.3. For this reason, its merits as a system for driving warships are obviously very few, as a single well-placed hit could easily disable the walking beam. This was true of crosshead engines as well. Consequently, no purpose-built warships in the United States used these engine designs.

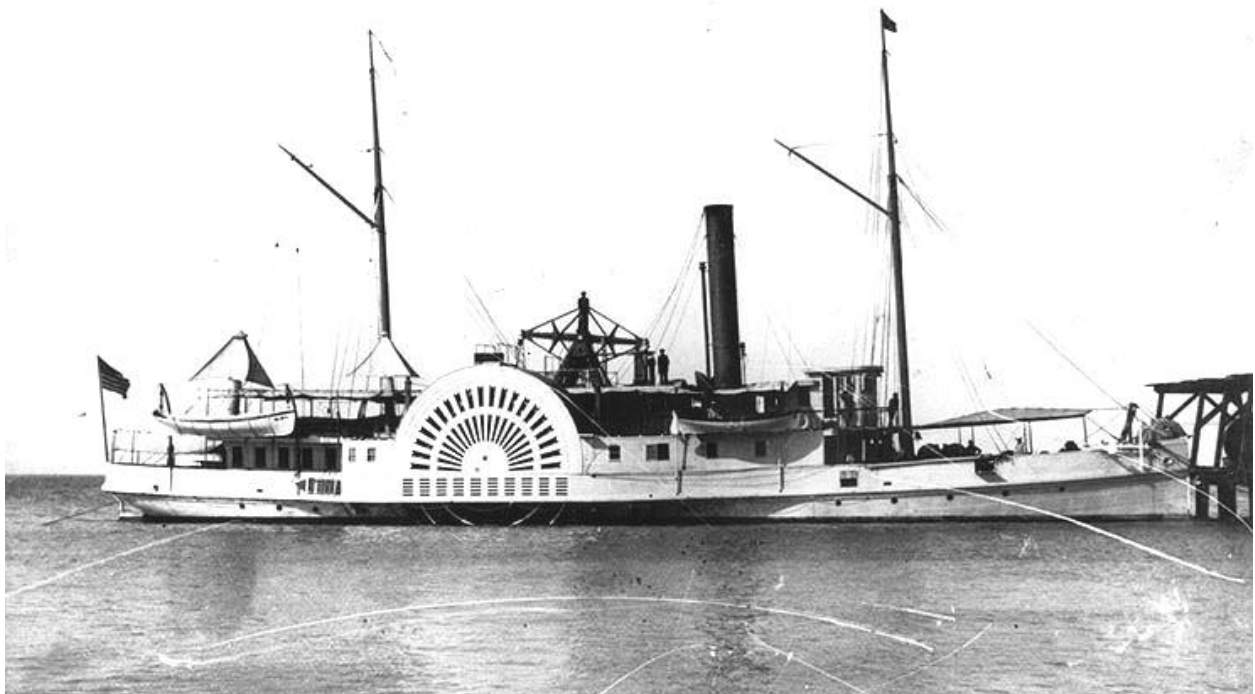

FIGURE III.3. United States Revenue Cutter *Louis McLane*, ex-USS *Delaware*, an acquired naval vessel—note the exposed walking beam (Online Library of Selected Images, Naval Historical Center, Department of the Navy, Washington, DC, 2012)

Another alternative to the crosshead engine which was popular in Great Britain and used in at least one important United States naval vessel was the side-lever engine. Many of the earliest naval steamers and merchantmen were driven by this engine, which was effective but quite large and heavy (Lambert 1992:170). In the United States, the pioneering paddle frigate USS *Mississippi* was fitted with British-style side-lever engines designed by Charles Copeland, superintendent engineer at West Point Foundry in New York (Tomblin 1988:61). Its sister-ship *Missouri* was built with inclined engines for the purpose of comparison. Unfortunately, *Missouri*

was destroyed by fire before the comparison trials were complete (Tomblin 1988:171). Despite the inconclusiveness of the results, and *Mississippi's* acceptable performance with side-levers, no more major American units were built with this engine type.

The side-lever engine worked on the same principles as the walking beam type, but was arranged in a slightly different manner, as shown in Figure III.4. Kevin Foster (1986:67) describes this complex arrangement best:

An upright, vertical cylinder pushed a long crosshead up and down. The crosshead was connected on each side to the end of a low-placed pair of center pivoted beams called side levers. . . The end of the side levers opposite to the cylinder used another connecting rod to turn the paddle crankshaft above them.

Side-lever engines were not much exposed above the waterline, but they were fairly complex and bulky. As such, they were not often used in naval vessels, and were not very common outside of Great Britain. By the 1860s more compact and powerful engines had become available, and side-levers and their variants went out of widespread use.

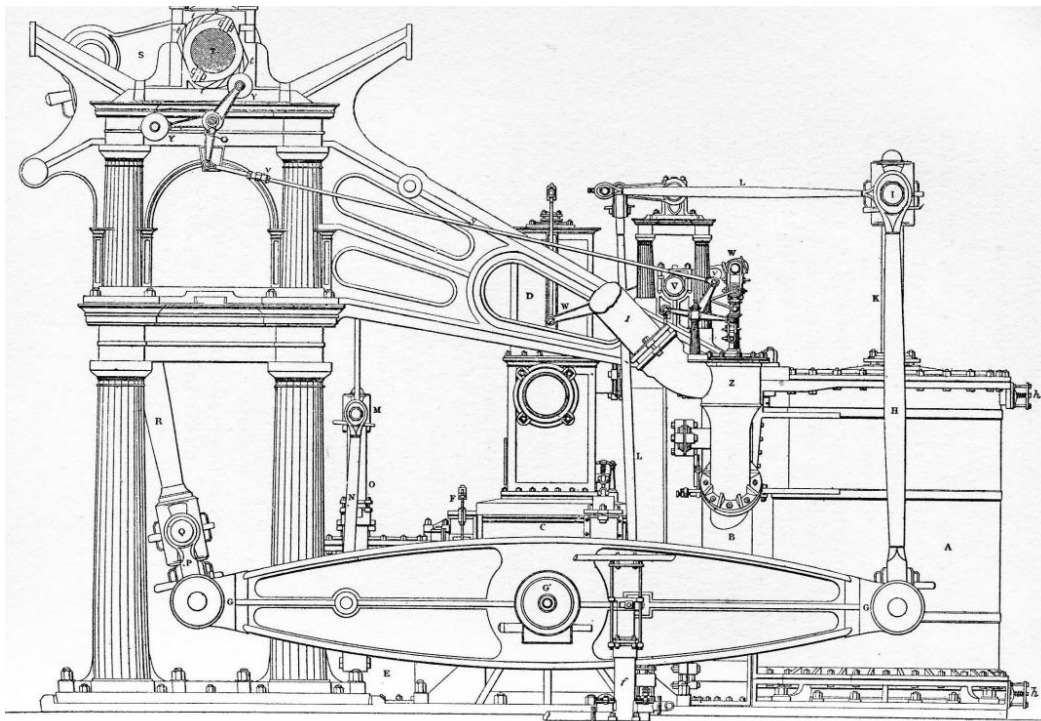

FIGURE III.4. A typical side-lever engine. Many early engines had decoration as shown here by the Doric columns. (Smith 1937:144)

British manufacturers were, for a time, determined to overcome the weaknesses of side-lever engines, resulting in the “Siamese,” “Gorgon,” and “grasshopper” engine designs. The first was patented in 1839 by Joseph Maudslay, and was used onboard a number of British paddle frigates. Maudslay’s twin-cylinder design “...quickly became known as a Siamese engine after the famous Siamese twins, Chang and Eng, then being exhibited in Britain” (Lambert 1992:170). This engine type became most widely-used in naval service, while Gorgon engines remained less common and grasshopper engines were best suited to small merchant vessels.

Siamese engines consisted of a pair of independent twin cylinders, with the piston rods connected to a crosshead above, which turned the main shaft via a connecting rod crank (Figure III.5). Air pumps and other equipment were also operated by the crosshead via extensions. “Ships were provided with two such engine units for each shaft, the engine units usually being capable of operating independently from each other” (Lambert 1992:170). This arrangement occupied less space than regular side-levers, had a longer piston stroke, and allowed for greater maneuverability, but it was still heavy and complex. Siamese engines were used onboard a number of British warships, including the famous screw sloop HMS *Rattler*, but never gained widespread use. No U.S. Navy warships utilized this design.

Gorgon engines were developed at about the same time as the Siamese type, and similarly remained an exclusively British design. They were patented by John Seaward and first used onboard HMS *Gorgon* of 1837, hence the common name. Gorgon engines worked by employing two vertical cylinders for each engine unit, positioned below the paddle shaft cranks, and linked to it by connecting rods. “Just as with the side lever engine, a parallel motion mechanism ensured that the piston moved vertically and a system of levers also operated pumps from the piston crosshead” (Lambert 1992:170-171). This layout can be seen in Figure III.6.

Gorgon engines were ultimately utilized by several British warships due to their relatively light weight, but they were never as common as Siamese engines.

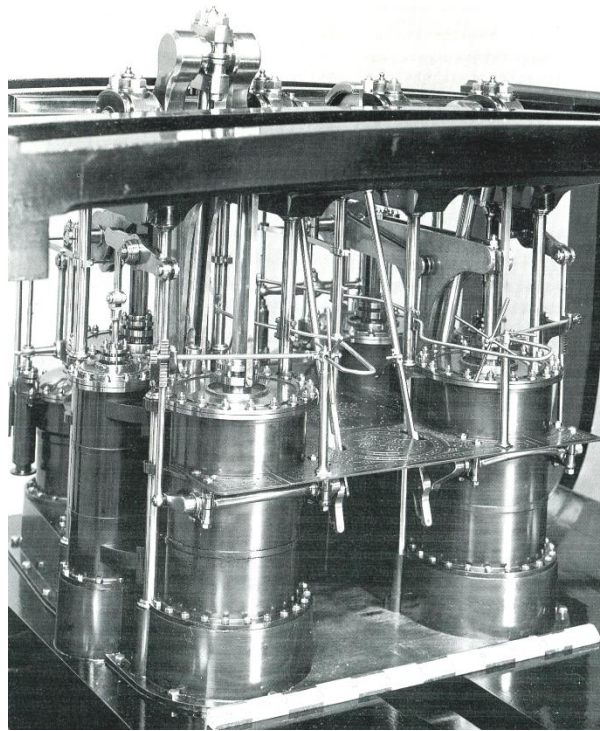

FIGURE III.5. Model of the 1841 paddle sloop HMS *Devastation*'s Siamese engines (Lambert 1992:171; courtesy of Science Museum)

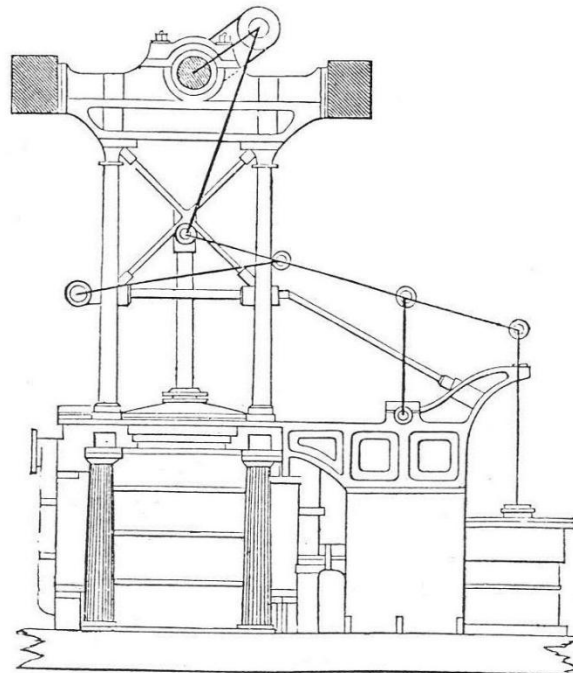

FIGURE III.6. Typical Gorgon engine (Lambert 1992:171)

Grasshopper engines were essentially a modified side-lever arrangement. The only real difference was the location of the pivot points—on the grasshopper design, the lever had the pivot point on one end instead of in the center, with the connecting rod attached toward the opposite end, as seen in Figure III.7. This created a “hopping” motion of the lever, resulting in this engine type’s given name. The grasshopper engine was never very common, and it still suffered the drawbacks of conventional side-lever engines in having a large size and weight. Its main advantages were cheapness of construction and robustness. For these reasons, the grasshopper engine was employed almost exclusively onboard tugboats and other small, hardworking craft.

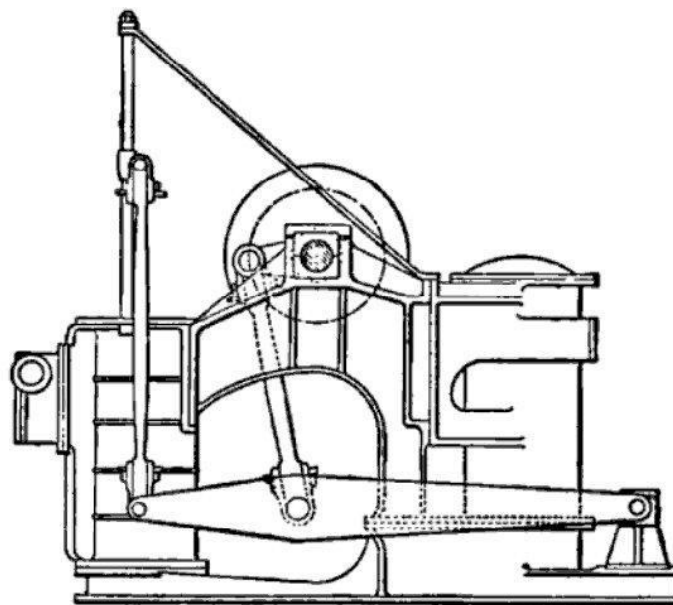

FIGURE III.7. Typical grasshopper engine (Seaton 1886:5)

A powerful and unusual engine type for paddle-driven vessels was utilized by some of the fastest ships of the 19th century. The oscillating steam engine came into favor beginning in the 1840s due to its compactness and lack of separate connecting rods. “That arrangement allowed for a long stroke and avoided the problems involved with connecting rod forces as well as the need for crosshead guides or parallel motion mechanisms” (Lambert 1992:171).

Oscillating engines were also lightweight and simple, but frequently suffered from loss of power from steam leakage. This was due to their unique design.

The oscillating engine, like so many other developments in steam technology, was first patented in Great Britain in 1827 by Joseph Maudslay and improved by John Penn in 1838. It was designed from the outset to overcome the problems with weight in side-lever engines and stability problems with crosshead and walking beam engines. There were no connecting rods on this engine. The cylinders, usually a pair, were mounted below the main shaft and designed to pivot on center trunnions. The crankshaft was thus driven directly by the piston rods as the cylinders themselves rocked back and forth, imparting a rotational motion to the shaft. Steam was delivered to and exhausted from the cylinders through the trunnions. Figure III.8 shows a diagram of this unique arrangement. (Foster 1986:67)

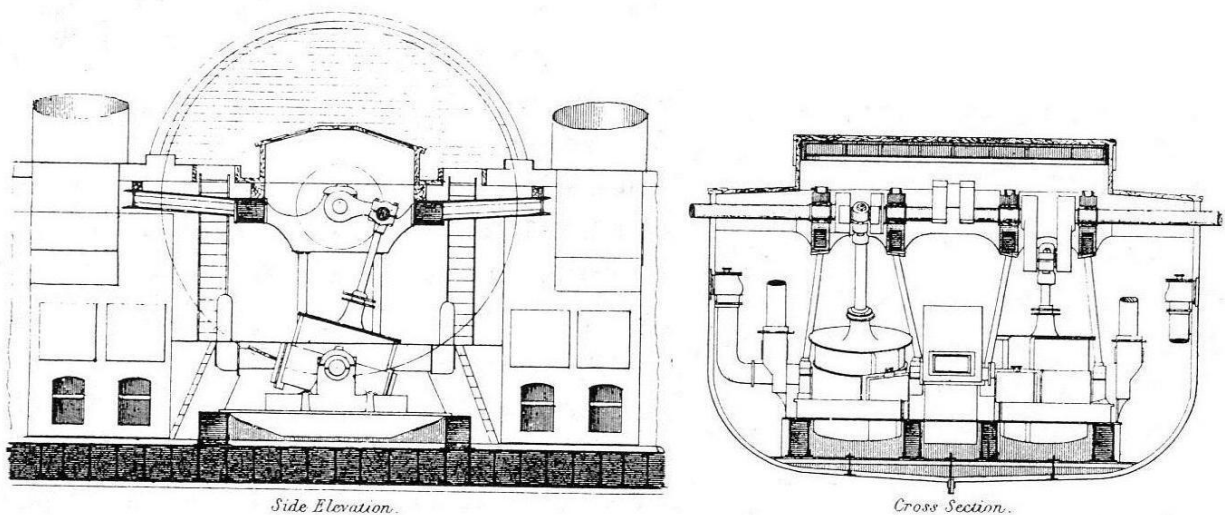

FIGURE III.8. Typical oscillating engines (Lambert 1992:171)

Many of the Confederate blockade runners and other fast steamships during the Civil War era utilized oscillating engines for their low center of gravity and high-speed capability. These engines were not well-suited for many other vessel types, and were not used by any Confederate ironclads. Major problems with the type included high cost, problems with the

steam joint at the trunnions, and a large amount of wear. The steam joint problem was never completely solved due to the ever-increasing operating pressure of new power plants. Despite these problems, it is fair to say that the oscillating engine represented a peak in steam engine design for paddlewheelers. Unfortunately, like virtually all paddlewheel machinery, it was not ideally suited for use onboard warships. (Foster 1986:67; Lambert 1992:171)

A final paddlewheel engine that was common in the United States was the direct-acting type. Its simplicity and versatility led to its adoption on a number of vessel types, and even allowed for adaptation to screw propulsion. There were a number of forms of this engine arrangement, usually designated by the cylinder's position relative to the keel. These were the "vertical" or "vertical inverted," "steeple," "return piston rod," and "inclined." In the United States the vertical inverted and inclined forms were by far the most common in the 1850s and 1860s. The inclined engine was favored for the ubiquitous Western river steamboats, while the vertical inverted was common onboard small coastal vessels and tugboats. Each form had its advantages and disadvantages, but as a whole the direct-acting engine was much favored in both the U.S. Navy and merchant marine during the mid-19th century. (Foster 1986:67-70)

Direct-acting steam engines, like virtually all other engines during the first half of the 1800s, were usually single-cylinder, simple expansion. They worked the same way no matter what their arrangement: the cylinder was positioned to transmit power directly to the crankshaft via the piston rod. In the vertical form, the cylinder was placed directly below the main shaft, while in the vertical inverted form it was placed over the shaft. A typical vertical inverted engine is shown in Figure III.9. The major drawback of these two forms was the short stroke resulting from the lack of space between the paddle shaft and engine in all but deep-draft hulls (Foster 1986:67).

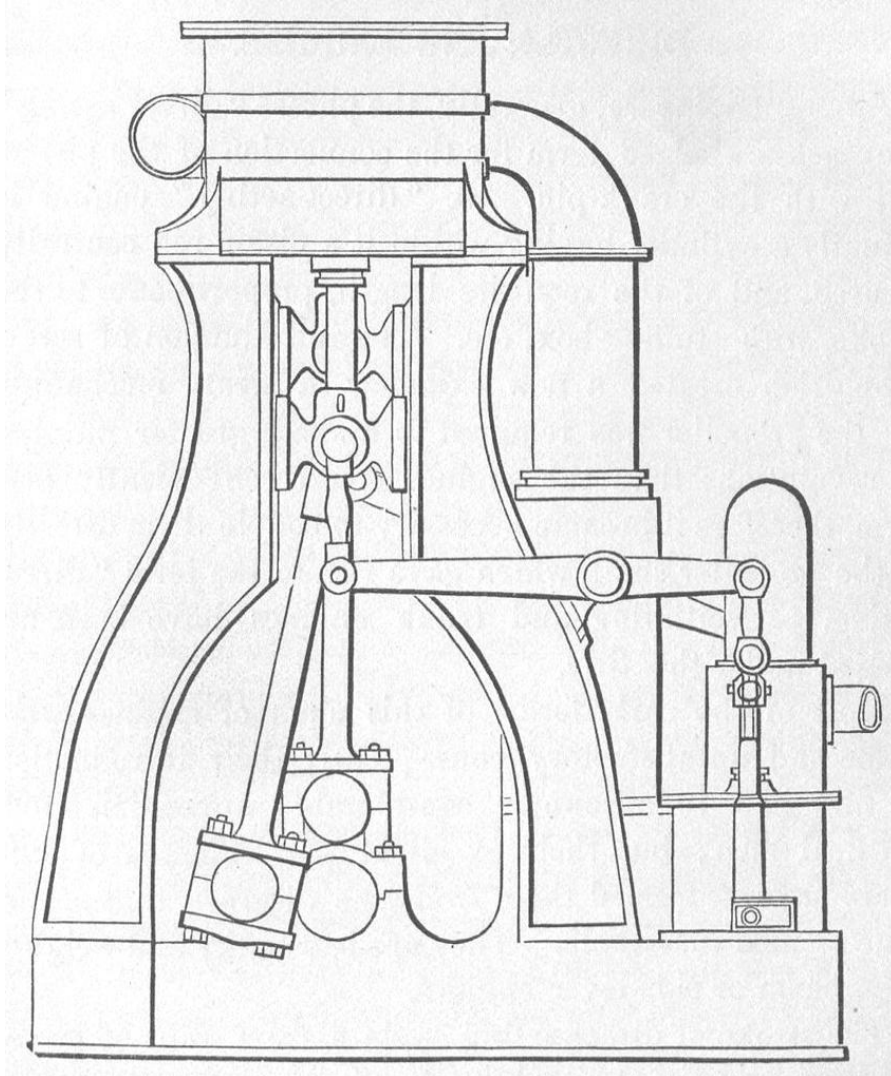

FIGURE III.9. Typical vertical inverted direct-acting engine (Roper 1897:204)

Steeple engines and return connecting rod engines were designed to avoid the disadvantages inherent with the short piston stroke of the vertical types. Steeple engines "...had two piston rods from the same cylinder connected over the crankshaft by a crosshead. A connecting rod returns from the crosshead down to turn the crankshaft" (Foster 1986:67). This arrangement was quite tall and bulky, much like the crosshead and walking beam types. It was so named because the guides for the crosshead usually extended above deck, were A-frame shaped, and when sheathed with a protective covering resembled a church steeple. Figure III.10 shows a diagram of this arrangement.

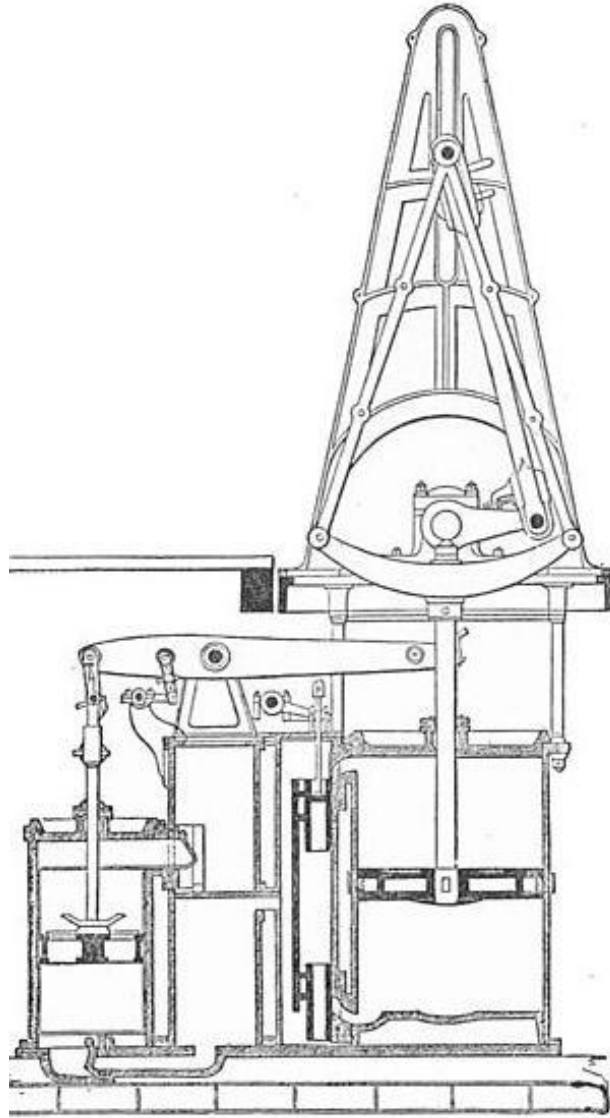

FIGURE III.10. Typical steeple engine (Kennedy 1905:56)

Return connecting rod engines used a single piston rod split into two or more arms which passed down each side of the cylinder and were joined by crossheads on either side. “A wishbone shaped connecting rod extended up from the short crossheads to turn the crankshaft above” (Foster 1986:67), as seen in Figure III.11. They were often called “back-acting” for this reason, and essentially acted as horizontal steeple engines. Steeple engines were not used much for naval service, but the back-acting type came to be used frequently onboard mid-19th century warships, and was easily adaptable to screw propulsion.

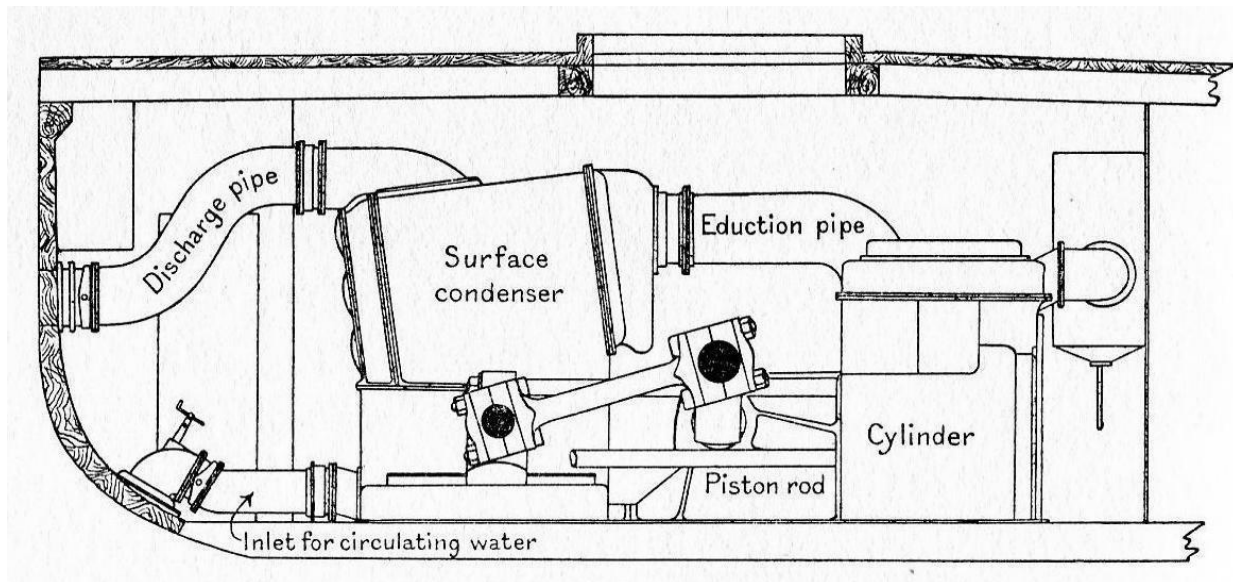

FIGURE III.11. Typical return connecting rod engine (Smith 1937:146)

Inclined direct-acting steam engines were the type most commonly used by the U.S. Navy in its paddle frigates. Their low profile made them preferable for rigorous service onboard warships, but inclined engines were also ideally suited for service onboard river steamboats. The design as applied to naval vessels was one of the most sophisticated used widely for paddlewheel propulsion (Foster 1986:70). As in the other direct-acting forms, a long connecting rod drove the crankshaft directly from the piston rod, but in this case the cylinder was positioned near the bottom of the hull below the waterline and angled upward towards the main crankshaft. A low profile, efficient, and relatively lightweight arrangement of machinery resulted, among the best that could be obtained for naval service. Many U.S. naval steam vessels, beginning with USS *Missouri*, used this layout.

An important and interesting outgrowth of the inclined marine steam engine, which also combined attributes of the horizontal direct-acting engine used for screw propulsion, was the type epitomized by the Western river steamboat. The shallow waters on which these boats ran emphasized light, flexible construction and small but powerful engines. A large area of even weight distribution and an efficient stroke made the inclined engine desirable, but many changes,

including a significant increase in operating pressure, were made to it, resulting in the type used onboard riverboats.

The availability of unlimited fuel supplies and the desire for simple mechanics led to the creation of the western rivers high pressure steam engine. The design incorporated a cylinder on each side of the hull to drive a crank on the sternwheel [or sidewheel] by using a very long wooden connecting rod called a Pittman. (Foster 1986:70)

This simple but powerful engine type was used onboard virtually every one of the thousands of paddlewheel steamboats plying the rivers of the Mississippi Basin and other rivers in the American South and West (Figure III.12). Although influenced by other factors, riverboat engines evolved largely through practical experience, with little thought being given to standardization of power plants or formally-trained engineers until after the Civil War (Bates 1996:7-8).

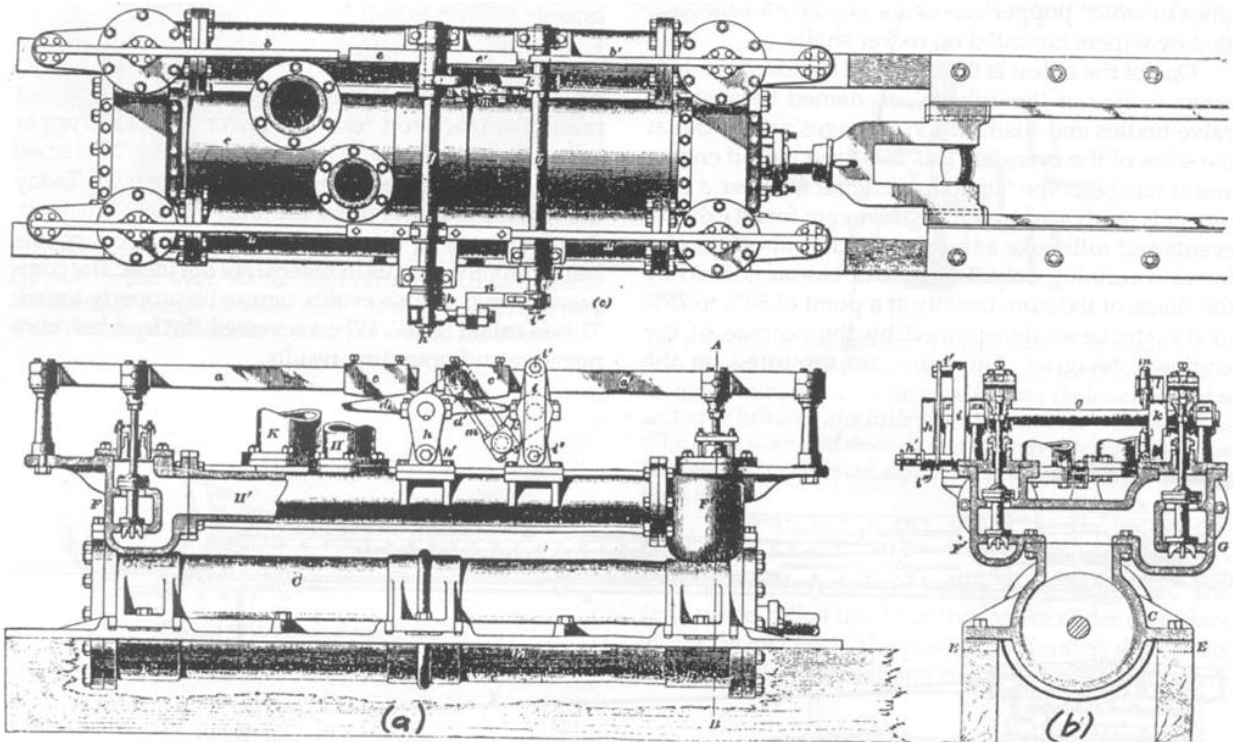

FIGURE III.12. Typical Western rivers steamboat engine (Bates 1996:42)

Former steamboat captain Alan Bates (1996:7) states, “In its fully developed form, basically achieved by 1840...”, the standard power plant of river steamers represented a marvel

of compact, simple engineering but remained inefficient and dangerous for many years due to the simultaneous abundance of fuel and lack of highly trained engineers. Other factors played into this as well, such as mud clogging the hot wells and pipes, the high operating pressure of the fairly brittle wrought iron boilers, and feedwater pumps that only functioned when the vessel was underway. Machinery of this type was utilized by the hundreds of steamers pressed into Union or Confederate war service in the West, and several sets of machinery were salvaged from wrecked boats for use onboard new vessels, including ironclads. Western riverboat engines and boilers were even adapted by the Confederates to turn screws. The relatively late arrival of screw propeller technology in the United States had left the South with a dearth of propeller engines, but there were several types in use in America by the 1860s.

Engines for Screw Propulsion

Screw propulsion, although still a new technology in the 1850s and 1860s, was quickly recognized as being much better-suited for warships than paddlewheels. Propellers and their accompanying equipment such as shafting took up much less space in a hull, were always capable of driving a vessel due to their submerged nature, and were also protected from damage for these same reasons. While these benefits were realized quickly, propeller design at first went in a few different directions. The screw itself created drag when a ship was under sail, and there were attempts to design different propellers with adjustable blades or capability of being disconnected while underway (Atherton 1851:45). Concerns such as these were primarily relevant to the very early days of screw propulsion, when efficient engines were just being developed. Like paddlewheel machinery, initial efforts in propeller technology used adapted existing technology before moving in different directions as data and experience accumulated.

By the Civil War, there were a large number of engine types designed for turning screws. A few of the older engine forms designed for paddlewheel propulsion were also utilized. These were the first to be used in conjunction with the new technology. Because of the relatively slow turning rate of paddlewheels, "...an engine need only develop about twenty-five revolutions per minute (RPM) to make a paddle-wheel practical" (Taggart 1991:99). Propellers, in comparison, need at least 50 RPM to function properly. In the first days of screw propulsion, therefore, the most common way to achieve the desired speed was through gearing. (Taggart 1991:99)

Before the widespread use of direct-acting engines for screw propulsion, it "...was considered impracticable, even in short-stroke engines [to obtain 50+ RPM], consequently, it was the universal custom to obtain it by the intervention of multiplying cog-wheels" (Roper 1897:208). These wheels were often fitted with wooden teeth when attached to the engine shaft, and iron pinions on the propeller shaft. Many vessels used this arrangement, including HMS *Rattler*, which was fitted with a Maudslay Siamese engine geared to the propeller shaft, and SS *Great Britain*, fitted with geared oscillating engines (Smith 1937:145). During the Civil War, several Confederate ironclads including *Tennessee*, *Tuscaloosa*, *Huntsville*, *Albemarle*, *Neuse*, and *Wilmington* were fitted with geared machinery of various types.

The use of geared engines, particularly in warships, was largely a stopgap measure until better systems were developed. In the case of the Confederate ironclads, the only available machinery was not ideal for screw propulsion, so gearing was used by necessity even at that late time. Geared engines had many disadvantages, including excessive weight and occupying more space than regular power plants (Roper 1897:208). After the 1840s, they had largely fallen into disfavor, as the direct-acting engine became more refined and popular.

The 1850s saw the flowering of the direct-acting engine type as applied to turning propellers. Compared to beam engine types, most forms of the direct-acting engine could be easily adapted to screw propulsion, and indeed a few forms were ideal for it. Direct-acting engines powered the propeller shaft directly, and were, therefore, capable of developing high RPMs through short-stroke motion. It did not take engineers long to realize the benefits of this mode of propulsion. The relative compactness and versatility of direct-acting engines led to widespread use in warships particularly, and a number of different designs were adopted. In 1858, an Admiralty R.N. Committee reported:

...that of all the variety of engines that have been purchased by Government for our screw ships of war, the following are so superior to all others, that no engines of an older make should ever again be put on board. The engines to which they now refer are:

- (1) The single piston-rod engine, with the connecting-rod attached direct to the crankshaft, and with a single flat guide.
- (2) The engine commonly known as the trunk engine, and patented by Messrs. Penn and Sons.
- (3) The double piston-rod engine. (Smith 1937:146-147)

The “single” and “double piston-rod” engines have already been mentioned, the latter more usually described as the back-acting or return piston rod type. The trunk engine, meanwhile, was a recent British invention widely adopted in ships of the Royal Navy, but not commonly used in the United States. The vertical inverted, horizontal, inclined, and “vibrating lever” engine types were the most common in the United States by the 1860s. Like the paddlewheel types before them, all of these engines had important advantages coupled with a few serious drawbacks.

By the 1860s, one of the most common types of engine was the single-cylinder, inverted, direct-acting variety. This engine was simple, reliable, and often quite compact, leading to its widespread utilization onboard small merchant vessels and tugboats. While originally designed for turning paddlewheels, it was found that the inverted engine was even better for turning a propeller shaft. In this arrangement, the cylinder was placed over the shaft with sufficient room

for the piston and connecting rods to turn the cranks. The resulting system was simple, open, and allowed for easy maintenance (Foster 1986:70). Its basic components did not change for many decades. A vast majority of the screw tugs of the Civil War period utilized this engine, and it found its way onboard a number of Confederate ironclads. An example, from an early 20th century New Orleans tugboat, is shown in Figure III.13.

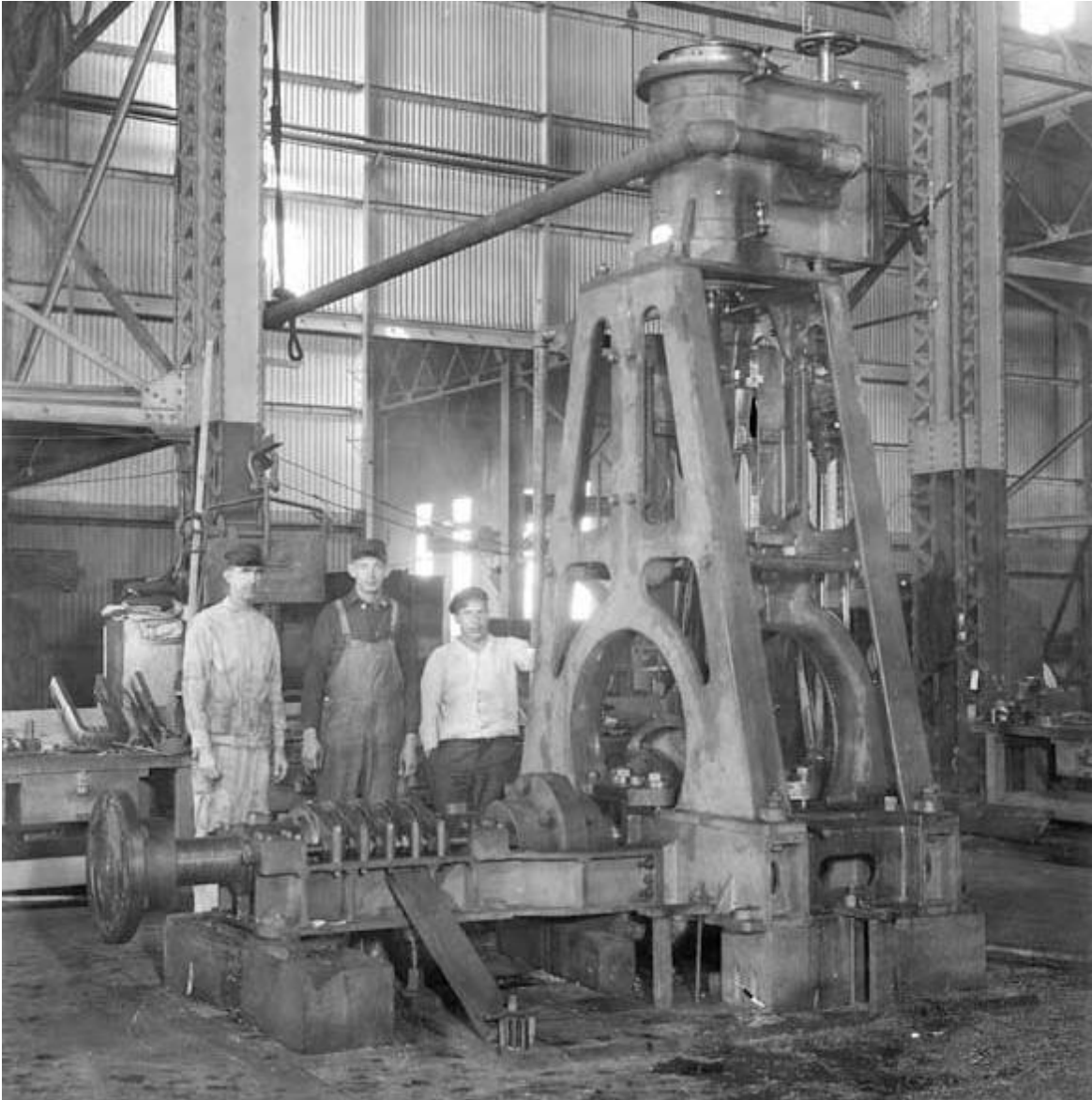

FIGURE III.13. Early 1900s single-cylinder, vertical inverted direct-acting screw-propelled tugboat engine (Online Library of Selected Images, Naval Historical Center, Department of the Navy, Washington, DC, 2012)

The vertical direct-acting engine was never widely used by propeller driven vessels due to the cylinder's awkward placement in the hull, underneath the shafting. This arrangement was ideal for paddlewheels, with the main shaft placed high up in the hull athwartships, but did not lend itself to propeller shafting placed low in the hull. Consequently, it was not used onboard any Civil War naval vessels. Likewise, the steeple engine, also developed for paddlewheel propulsion, was not ideal for naval vessels or turning screws. The steeple engine's exposed arrangement and bulk led to the gradual disappearance of the type after the 1840s, although it had been well-developed in a horizontal form for warships by the British. One of USS *Merrimack's* sisters, *Wabash*, was powered by horizontal steeples, but no Civil War ironclad employed this engine type (Silverstone 2001:4-12,16,151-157).

Oscillating engines, the epitome of paddlewheel power plants, were also sometimes adapted to propeller-driven vessels. This was done by placing the engines above the shafts at an inclined angle. Oscillating engines were "...often used in multiples at right angles similar to a V-8 automobile engine" (Foster 1986:70). Despite the relative simplicity of this arrangement, the oscillating engine still encountered the same problems of steam leakage and cost of maintenance. Like most of the other engine types, it was gradually displaced by the vertical or horizontal direct-acting types.

The most popular engine for screw warships during the Civil War period was the horizontal direct-acting form. This arrangement offered low clearance for beneath-the-waterline protection, while at the same time retaining an open, simple, and easily-accessible layout. Its inherent disadvantages lay in the extremely short stroke and lack of athwartships space in the bottom of a vessel's hull. This disadvantage was exacerbated in deep-bottomed seagoing vessels. Shallow-draft, flat-bottomed warships such as the Confederate ironclads were much better suited

to this engine type. Indeed, the horizontal direct-acting engine was the most common purpose-built engine used by the Confederate Navy. Figure III.14 shows the only known preserved example of this engine type in the United States: the twin engines of the wooden gunboat CSS *Chattahoochee*. About 30 feet of the scuttled gunboat's stern, including the machinery, was raised from Georgia's Chattahoochee River in 1964. The engines are now at the Port Columbus Civil War Naval Museum, a rare surviving example of Civil War steam technology. (Foster 1986:70; Lambert 1992:172)



FIGURE III.14. The two horizontal direct-acting engines of CSS *Chattahoochee*. Each engine turned one screw on the opposite side of the hull from the cylinder head. (Online Library of Selected Images, Naval Historical Center, Department of the Navy, Washington, DC, 2012)

An important development of the horizontal direct-acting engine was the trunk engine, patented in Great Britain by John Penn. It was first employed by the Royal Navy in the mid-1840s and became quite popular for use on warships, the most famous example of the type being used onboard the ironclad HMS *Warrior*. In this arrangement, the problems inherent with a short

stroke and short piston rod were solved by a clever method of accommodating a long connecting rod. “A circular trunk fitted to the piston allowed for movement of the connecting rod, that trunk being like a hollow piston rod which projected through the covers at both ends of the cylinder” (Lambert 1992:173). Figure III.15 shows an example of this layout. While it proved to be powerful and reliable, Penn’s trunk engine did have some problems. The large head glands of the enlarged cylinders often leaked, the engines were costly to maintain, and access to the moving parts was difficult. Trunk engines were not widely employed outside of Britain, although they long remained a favorite of the Royal Navy.

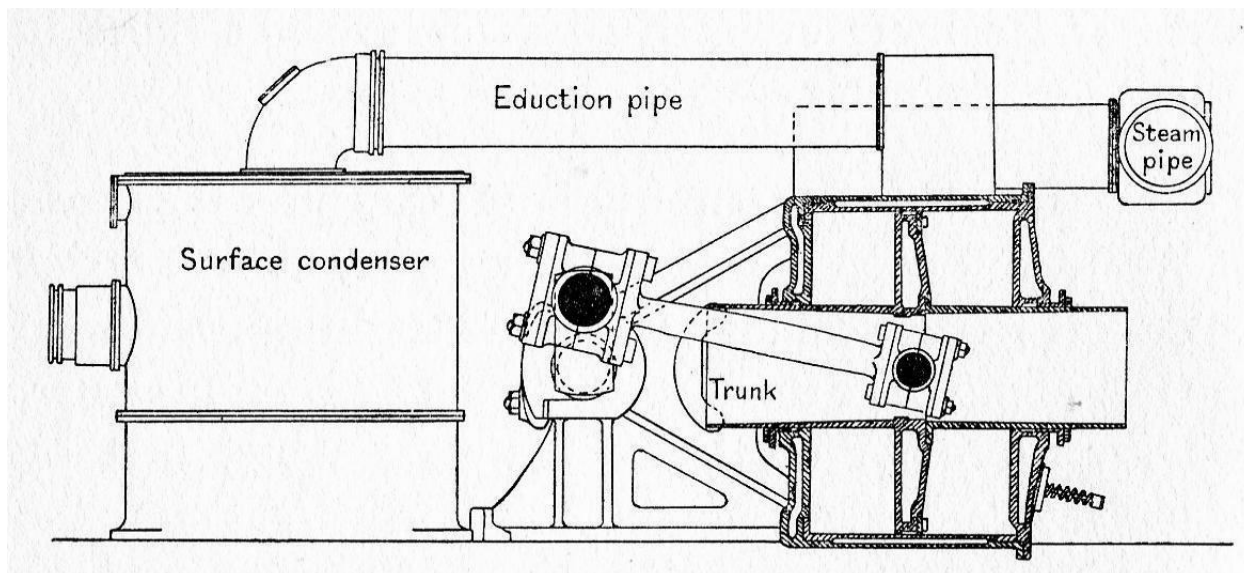

FIGURE III.15. Typical trunk engine (Smith 1937:146)

A unique derivative of the trunk engine was the vibrating lever, or “half trunk” engine patented by Swedish inventor and the “father of monitors” John Ericsson. In order to save space in the cramped confines of USS *Monitor*’s below-deck spaces, Ericsson developed an engine that worked on similar principles to the trunk engine, but saved even more room. Two cylinders were placed facing each other above a central crankshaft, which was turned by a series of connecting rods and levers (Figure III.16). This resulted in a unique and compact motion, but Ericsson’s engine was never used outside of the United States and his native Sweden. The vibrating lever

type was used almost exclusively for powering the Federal monitors during the Civil War, and did not see use onboard any Confederate vessel.

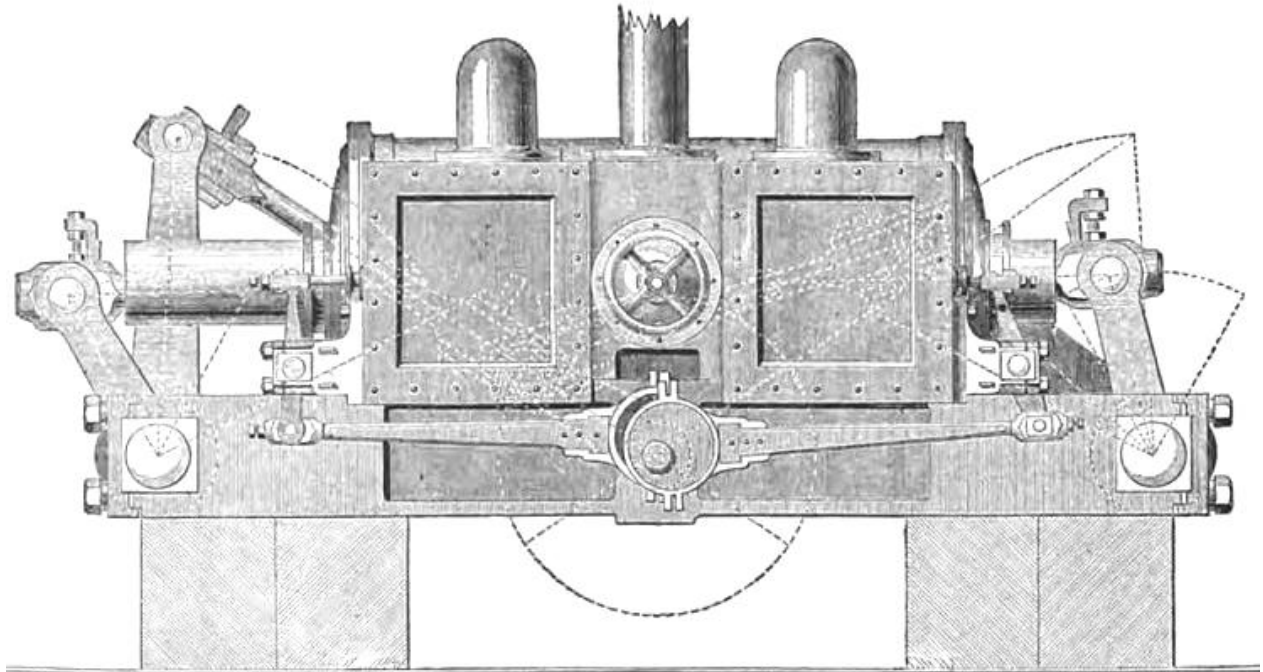

FIGURE III.16. Ericsson's vibrating lever-type engine as built for the 1863 monitor USS *Monadnock* (Hutton 1897:53)

Return connecting rod engines, yet another outgrowth of the horizontal direct-acting type, were also fairly common during the Civil War. This engine type was also originally used for turning paddlewheels, but its arrangement lent itself quite readily to turning screws. The return connecting rod engine, like the trunk engine, was an attempt at a horizontal layout without the problems suffered from short connecting rods. It appears that Maudslay was the originator of this design, beginning in the 1840s. Although the return connecting rod engine benefitted from a long stroke, it still "...took up a considerable amount of space and was relatively complex, additional components also being required" (Lambert 1992:173). Even with these deficiencies, this engine was used onboard a number of large warships, and was quite popular by the 1860s. Perhaps the most famous example of this engine type is the power plant provided for the first United States

steam frigate, USS *Merrimack*, in 1854. This vessel would later make history as the ironclad CSS *Virginia*, still utilizing the return connecting rod engines of its first incarnation.

The final screw propeller engine type discussed here is the inverted, inclined direct-acting form. This engine was used onboard paddlewheel driven vessels, but like many others was adapted and refined to drive propellers. This layout was not common onboard propeller-driven U.S. naval vessels, but was useful in small vessels with multiple screws, such as large tugboats and icebreakers. Figure III.17 shows an example of this arrangement. The most famous example of this engine type in America during the Civil War era is probably the twin-screw towboat / icebreaker *Enoch Train*, built in Massachusetts in 1855. In 1861, this small but powerful vessel was converted into the first North American ironclad, CSS *Manassas* (Campbell 2006:48).

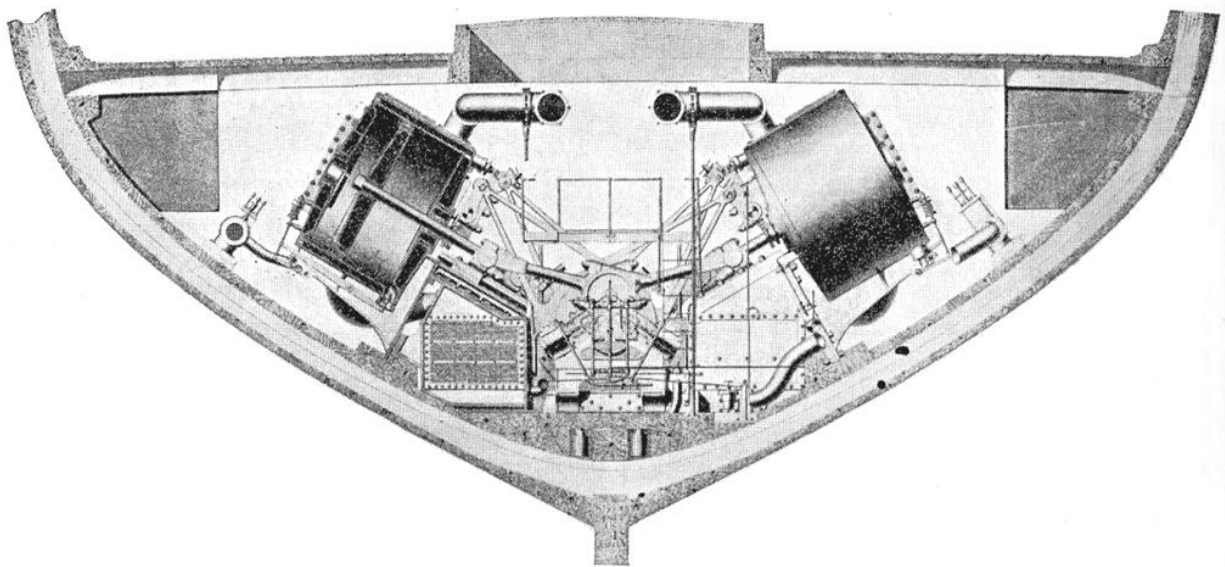

FIGURE III.17. Inclined inverted direct-acting engines of the 1863 screw frigate HMS *Constance*. Although this particular example is a British compound, its layout is representative of regular inclined engines as installed on CSS *Manassas*, ex-*Enoch Train*. (Lambert 1992:174)

Screw propulsion, although it was still in contention with paddlewheel drive during the Civil War, ultimately superseded all other forms of powering a ship. The myriad engine designs, both those originally developed for paddlewheels and those invented for propellers, faded away

into a few dominant types. By the post-Civil War era, the horizontal and vertical inverted direct-acting engines had superseded almost all other forms, and the latter soon evolved into the prime mover of world shipping during the late 19th and early 20th centuries: the vertical triple-expansion engine. By that point, almost all of the defects encountered in powering a vessel with screws had been overcome. Therefore, the widespread experimentation with and utilization of widely varying propeller engine types during the 1850s and 1860s contributed significantly to the realization of the modern screw-propelled steel-hulled warship.

Boilers

Boilers, the heart of the steam engine system, grew in size, efficiency, and complexity during the period between 1800 and 1860. There were never as many types of boilers as engines, but a number of different designs were experimented with and utilized for widely-differing activities. For instance, one type of boiler was ideally suited for powering steam locomotives, and another seemed best used for sawmills or other industrial machinery. Boilers for oceangoing vessels were different in design than those used onboard riverboats. Each boiler type had distinct qualities for its form of service. Despite these differences, boilers during the first half of the 19th century required the same care and quality components.

As Roper (1897:350) notes, “The three most important objects to be attained in the design, construction, and use of steam-boilers are, ‘safety,’ ‘durability,’ and ‘economy’”. These factors determined design and quality of construction, which remained quite important as improperly-built or badly-cared-for boilers could explode. Indeed, the early history of steam navigation, particularly on the Western rivers, is marked by hundreds of fatal explosions (Bates 1996:10-11). Unfortunate incidents such as these helped push the development of safer and more efficient boiler designs in merchant vessels. Naval vessels always had higher-quality steam

generators, at least on paper, and accidents relating to boiler explosion in warships seem to have been considerably rarer. This had as much to do with quality construction and care as type of boiler employed.

By the time of the Civil War, there were three main types of boiler in use, both onboard ships and on land. All burned coal or wood. Plain cylinder, flue, and tubular boilers were developed in that order, but the most common by 1860 was the flue boiler. The tubular boiler had begun to come into its own during this time, especially in Great Britain, while the plain cylinder boiler remained in use in small manufacturing establishments due mainly to its simplicity. All three had their adherents and detractors, but as Roper (1897:350) points out:

...experience has shown, in all individual cases, that the durability of a steam-boiler depends on the quality of the material and the character of the workmanship used in its construction, the facilities afforded for cleaning, repairing, and renewal of any of its parts, and also the care and management after being put in use.

A brief listing of the three boilers' attributes reveals their ideal uses. Plain cylinder boilers had the advantages of simplicity, ease of maintenance, and suitability for rolling mill and blast furnace operations, but were handicapped by extreme length and wastefulness of fuel. They were not used on steam-driven vessels. Flue boilers were smaller, required less fuel, and had a larger heating surface. They were very common for shipping interests, especially riverboats. Unfortunately, flue boilers weighed more, and were more difficult to clean or repair. This type of boiler also required more care "...on account of the liability of the flues to become overheated and collapse in case the regular supply of water should be neglected" (Roper 1897:352). Tubular boilers, meanwhile, possessed many advantages, but were more complex, making them more expensive to build and maintain. This last form of boiler occupied less space, required less fuel, and was not liable to collapse. By the end of the 19th century, the tubular type superseded all

other forms in oceangoing vessels, but this important transition did not begin to occur until after the Civil War. In the meantime, several variations of these three basic types were utilized.

The majority of the early history of steam navigation outside of the Western rivers was dominated by the low-pressure system, employing both flue and, later, tubular boilers. There was a strict adherence to generating power at or only slightly above atmospheric levels, even as engines and boilers increased greatly in size, power, and efficiency. Even the introduction of tubular boilers and direct-acting engines did not lead to an immediate change from low-pressure steam, saltwater feed, and jet condensers (Smith 1937:125). Most of the early boilers, such as those used onboard HMS *Comet* of 1828, were large, boxlike, and contained a mazelike series of flues leading from internal furnaces (Figure III.18). Consequently, these took up a great deal of room and were difficult to clean. The common use of saltwater only added to the problem, but by the 1850s this boiler form was still in use onboard many merchant vessels.

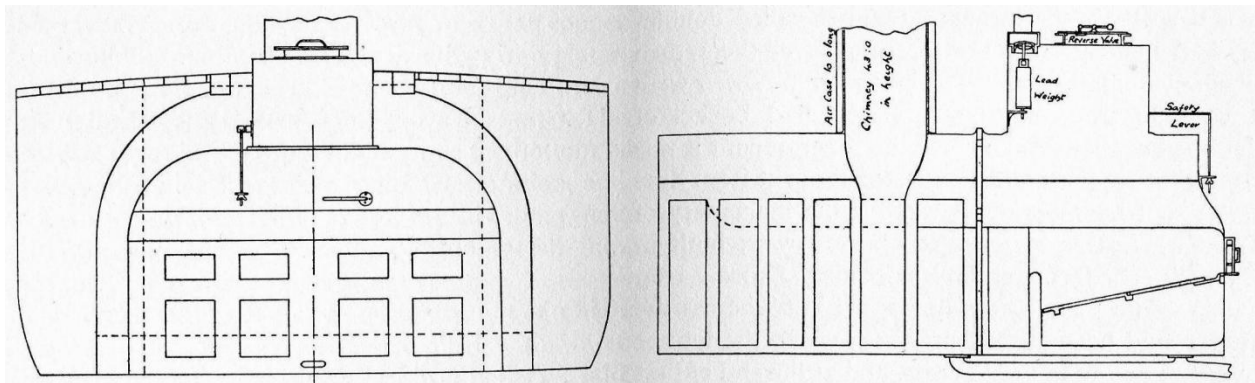

FIGURE III.18. 1828 rectangular flue boiler of HMS *Comet* (Smith 1937:127; courtesy of Birmingham Reference Library, Birmingham, UK.)

Tubular boilers were quickly adopted by navies once they had been sufficiently proved. This type of boiler took two forms: firetube, in which the many small tubes acted as miniature flues, and watertube, in which the combustion gases surrounded small water-filled tubes. There were both horizontal and vertical forms. The compact horizontal “Scotch” form was the most commonly used (Figure III.19). The vertical design was often employed in small auxiliary

systems, but was also found onboard some major warships, including USS *Merrimack* of 1854 (Figure III.20). Average size was about 10 feet in diameter by 15 feet long. All forms of the tubular boiler were more efficient at transmitting heat to the contained water, but were not as good for perfect combustion as flue boilers (Atherton 1851:40-41). Like many oceangoing systems, they were commonly low-pressure.

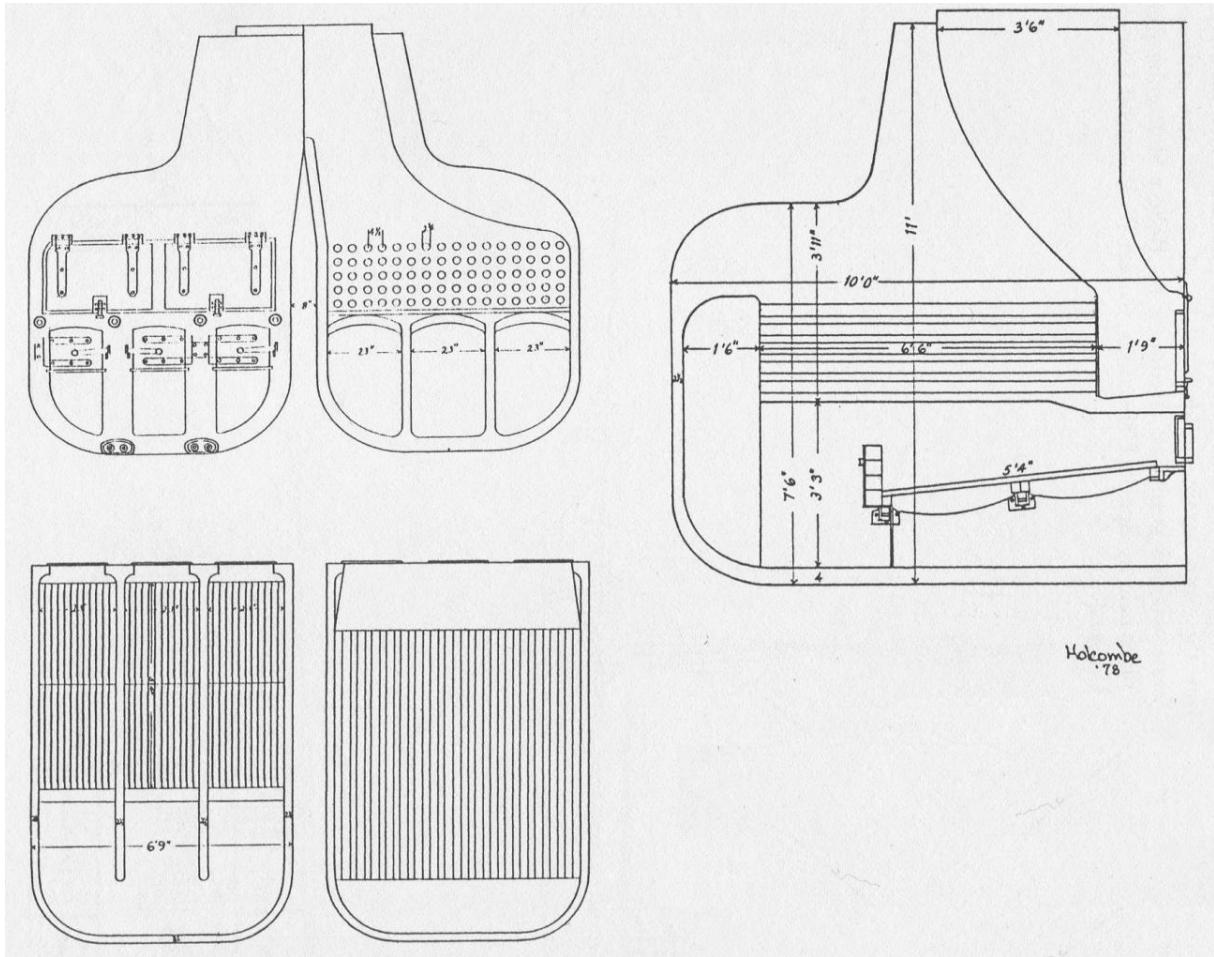

FIGURE III.19. Low pressure “Scotch” marine horizontal firetube boiler, used onboard several Confederate ironclads (Still 1987:58; courtesy of A. Robert Holcombe, Jr.)

Some explanation of the terms “high-pressure” and “low-pressure” must be given before discussion of Western rivers steamboat machinery. Low-pressure systems are generally those operating at or slightly above atmospheric pressure. For most of the 19th century, oceangoing vessels, both merchant and naval, operated on low-pressure. The terms relating to pressure were

liable to change, as better-quality construction, understanding of physical principles, and improved designs were incorporated into marine boilers. As Smith 1937:133 states:

...in marine engineering, the term high-pressure was applied to steam at even 15 lb. per square inch. It may be taken that in the [eighteen] ‘thirties ordinary steam pressure in marine boilers was 5 lb., the ‘forties, 10 lb.; and in the ‘fifties, 20 lb.; and vessels using steam at any pressures in excess of these would be considered as using high-pressure steam.

These “high” pressures paled in comparison to the 100 or more pounds per square inch being employed onboard Western river steamboats, but professional engineers, especially naval ones, tended to be cautious. This sensible and careful approach to rapidly changing technology stood in stark contrast to the no-nonsense attitude of steamboat engineers and the nearly headlong rush into high-pressure systems.

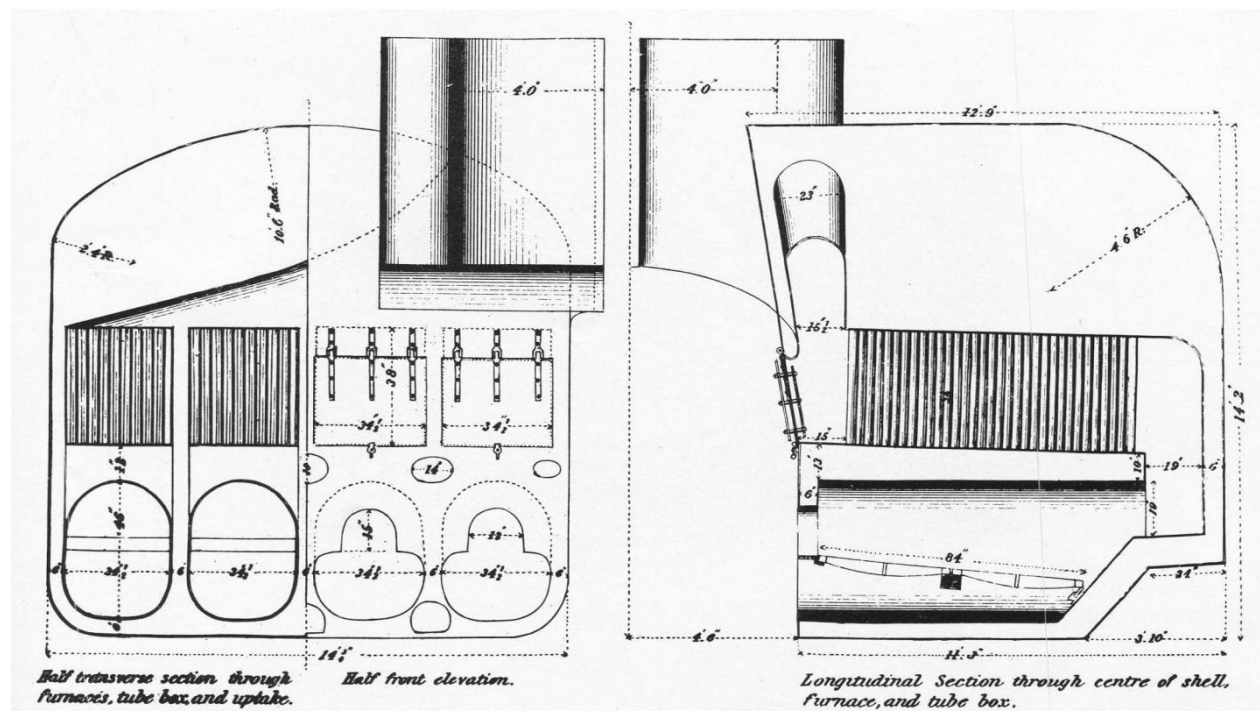

FIGURE III.20. Martin vertical watertube marine boiler of CSS *Virginia*, ex-USS *Merrimack* (Bathe 1951: Plate II; from Isherwood 1863)

Western river steamboat boilers were a marvel of practicality and power generation. These were of the flue type, but evolved in such a way that they must be considered separately from oceangoing designs. The Western rivers design almost always employed the double-flued

boiler contained in a battery of two or more or, in at least one case, sixteen (Bates 1996:10). The average size of these boilers was about 36 inches in diameter and 28 feet long. The length helped to spread the weight evenly over a riverboat's flexible hull, while the low profile was useful for saving vertical space. The majority of the Western riverboats burned wood, although coal was used when it could be obtained. Maintenance was always a necessity, as this boiler was more prone to explosion than any other type. This was due to the use of steam at pressures exceeding 100 pounds per square inch, and the difficulty in constantly cleaning flue boilers. Figure III.21 shows this boiler type's layout. Besides the "Scotch" marine tubular boiler, the Western rivers-style boiler was probably the most common form employed onboard Confederate ironclads during the Civil War.

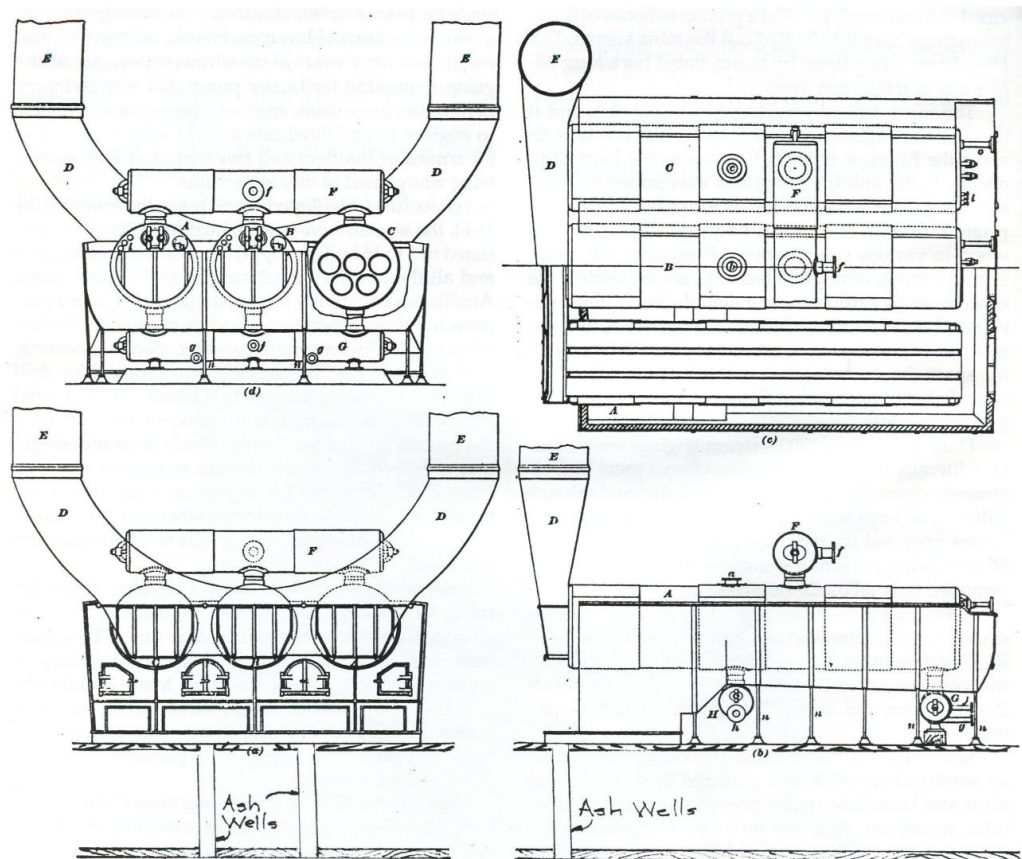

FIGURE III.21. Typical return flue boiler layout of Western rivers steamboats (Bates 1996:8)

A final type of boiler sometimes used onboard steamships was the locomotive, or firebox, style. In at least one case, that of CSS *Neuse*, a locomotive boiler was adapted to power an ironclad. This form was a derivative of the watertube type, and its size could vary widely depending on the locomotive. It could not compete with the double-flue boiler of the Western rivers for simplicity, although it was employed on steamboats occasionally. The main issue, according to Bates (1996:11), is that: “While locomotive...boilers are more compact..., they are difficult to clean and the hundreds of staybolts gave trouble”. The locomotive boiler is not known to have been used on any American naval vessel other than *Neuse*. Figure III.22 shows an example of this type.

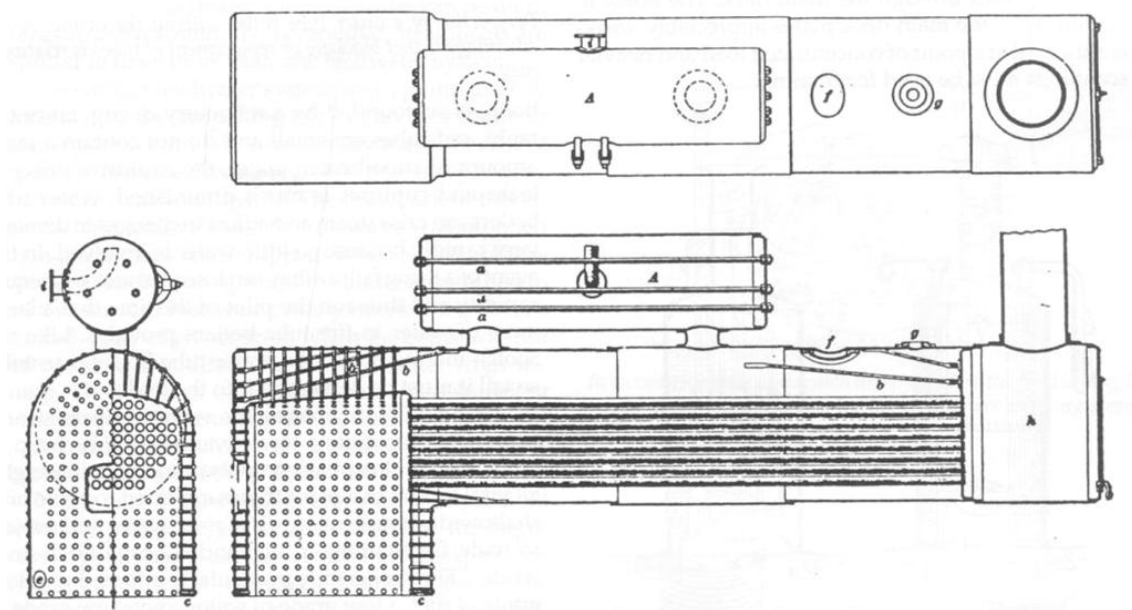

FIGURE III.22. Typical locomotive or firebox boiler (Bates 1996:11)

The majority of the Confederate ironclads were powered by the marine tubular boiler or the Western rivers double-flue boiler. These differing systems were more often than not taken from previous vessels, but all-in-all the boilers of Confederate ironclads proved less troublesome than the engines. Boiler technology development had stabilized somewhat by the Civil War, and engineers, both naval and merchant, were plenty familiar with the three main types. Although

there was no consensus on what boiler type was best, 1860s-era boilers were nearing an ideal level of efficiency, reliability, and power generation.

Conclusions

The development of steam machinery and all its components in the first half of the 19th century followed an explosive pattern. Many new ideas were tried, both in Great Britain and the United States, but only a few proved worthy in the long run. By the Civil War, significant advances had been made in providing reliable power to both merchant and naval vessels. While Great Britain remained the leader in maritime technology until near the end of the 1800s, American engineers and inventors made important advances of their own. They built the world's first steam-powered warship in 1814, and by the 1860s the paddlewheel-driven river steamboat had conquered the American West. This spirit of innovation led to what was probably the world's second- or third-largest shipbuilding industry by the Civil War. During that conflict, the Confederacy produced a number of its own steam engines for use onboard warships, but these proved a far cry from those built in the Union and Great Britain.

Many of the engines discussed in this chapter were never utilized by American naval vessels, or were rarely used, but they represent the differing ideas on both sides of the Atlantic regarding maritime machinery. American designs tended to be simpler and more rugged than British ones. As a rule, the steam machinery used in the Confederate ironclads reflected standard American practice, but was often even simpler than machinery employed onboard Union vessels. While this certainly did not assure reliability, it was ideal for warships built by a nation with little experience in marine machinery manufacture.

The majority of Confederate ironclad power plants were removed from other vessels, almost always tugboats or river steamboats. The preferred types were variations of the direct-

acting layout—these systems were practical and simple. Too often, though, they were underpowered for driving a heavily-armored warship. Even the ironclads utilizing powerful engines such as those onboard CSS *Manassas* often had problems with maintaining steerageway or maneuverability. Even the best early-war power plants, purpose-built or otherwise, were handicapped by excessive weight. This problem was gradually overcome, for the course of the war saw great progress in the advancement of steam engine technology.

CHAPTER 4: MANUFACTURERS AND OTHER SOURCES

The Confederacy lacked the industrial infrastructure of the Union, but it did have several facilities that came to be of great importance to the wartime production of marine steam machinery. Foremost among these were the great Tredegar Iron Works in Richmond, Virginia, and the Confederate Naval Iron Works in Columbus, Georgia. These two facilities and their contracts with smaller local establishments accounted for the majority of new ironclad machinery construction in the South.

Machinery for steam-driven warships was also by necessity obtained from many other sources. The exact number of facilities capable of producing effective marine engines in the Confederacy is difficult to determine (Still 1965:287-288), but the manufacturers involved with ironclad construction are better known. Unfortunately for the historian, many Confederate ironclads received their machinery from river steamers with unrecorded or unknown construction histories. Lack of manufacturing and prevalence of generic river vessel types on the South's inland waterways led to this stopgap measure.

Aside from high-pressure steamboat machinery and purpose-built engines, a number of Confederate ironclads received their power plants from more unusual sources. These included a lightship engine for *Richmond*, tugboat engines for *Chicora*, *Palmetto State*, and *North Carolina*, and probably locomotive engines for *Neuse* (Still 1997:66-67). Exact provenance for much of this machinery remains a mystery, but future archaeological investigations of existing wrecks could provide more definitive answers.

In order to better understand the characteristics and defects in both the construction process and actual use of ironclad power plants, a discussion of the facilities that supplied marine machinery is necessary. Therefore, the history of each establishment will be discussed briefly

here in conjunction with the particular products it supplied to the Confederate ironclad program. This discussion will begin with the Tredegar Iron Works, the greatest manufacturing center in the South.

Tredegar Iron Works

The mighty establishment that was the Tredegar Iron Works during the Civil War had humble beginnings dating back approximately 30 years. A Virginia blast furnace operator, Francis Deane, Jr., laid plans in 1836 to construct a new iron foundry. On a narrow plot of land in Richmond between the James River and Kanawha Canal, an engineer from the town of Tredegar in Wales designed the new facility. The new foundry, rolling mill, and forge were accordingly named Tredegar in his honor. Railroad iron was the main product of the new company, but it quickly fell on hard times following the 1837 economic crisis. Tredegar limped along until 1841, when it was sold to young and ambitious Joseph Reid Anderson, a West Point graduate (Dew 1966:3-5). This man's incredible organizational and leadership abilities would result in an industrial complex rivaled only by those in the North.

The new owner of the iron works quickly began to implement changes and improvements that lasted through the 1840s and 1850s. By 1861, Tredegar had become a "...superb heavy industrial complex, capable of turning out large quantities of ordnance, munitions, armor plate, and a host of desperately needed iron products [including steam engines]" (Dew 1966:2). Multiple blast furnaces, rolling mills, forges, and machine shops now fueled the Confederate war effort. Anderson's facilities were the largest and most important industrial center in the South until shut down in April 1865, when the photograph shown in Figure IV.1 was taken.

While it is certain that Tredegar produced steam machinery during the Civil War, it is uncertain if it built all the engine components for ironclads. Anderson had contracted with the

government to provide the plates, spikes, engines, shafts, and armament for ironclads built in Richmond (Dew 1966:265). Three vessels, *Fredericksburg*, *Virginia II*, and *Texas*, seem to have been fitted out by Tredegar, but *Fredericksburg* and *Virginia II*'s power plants may have been built by the Confederate Naval Works (formerly the Shockoe Foundry) under contract to Tredegar. *Texas*' engines were never installed, but as they apparently came from a wrecked British blockade runner, that ironclad will not be further discussed.



FIGURE IV.1. Tredegar Iron Works photographed in 1865 at war's end (Civil War Trust 2011)

CSS *Mississippi*, the largest war vessel constructed by the Confederacy, had to have its giant center propeller shaft forged by Tredegar. No foundry in New Orleans, where the ship was being built, could produce the 50-foot long wrought iron piece called for (Merrill 1962:90-91). In response to this dilemma, Asa and Nelson Tift, *Mississippi*'s builders, and Secretary Mallory contracted with Tredegar to forge the shaft from the burnt-out steamer *Glen Cove*. The piece was painstakingly removed from the wreck, but no steam hammer in the Confederacy was capable of

working such a large shaft, which had been built in the North. Tredegar therefore had to resort to reworking it by hand (Luraghi 1996:123). Two roughly 20-foot long sections were eventually completed with some difficulty. Fifty men labored night and day for two months to complete the work, and a special railroad car needed to be built to transport the immense piece of iron to New Orleans. The shaft and center screw had just been installed when *Mississippi* was burned to prevent capture on 24 April 1862. (Confederate States of America [CSA] 1863:128)

Steam machinery for ironclads other than those in Richmond possibly built by Tredegar includes the power plants for the North Carolina vessels *Raleigh* and *Albemarle*. At least some of the components were definitely supplied by the Richmond firm, and probably many of the auxiliary components and even boilers were furnished there. As with all iron manufacture in the Confederacy, the production and supply system was divided inefficiently between whatever establishments could produce necessary parts.

Comparatively little is known about the engines of *Raleigh* and *Albemarle*. The former was a *Richmond*-class vessel built in Wilmington, North Carolina from 1862 to 1864. The first attempt to power the vessel was initiated by obtaining the engines of the wrecked blockade runner *Modern Greece*, but the salvage effort failed. Archaeological investigations in 1994 revealed the engines as installed were the single-cylinder direct-acting horizontal type, but the builder's plate was not found (Peebles 1996:35,99). The vessel's motive power as finished was considered above average during its short career. It appears that this power plant was manufactured in Richmond, as the Tredegar Iron Works produced the armor and possibly fittings for several North Carolina ironclads (Still 1969:35). A direct reference to *Raleigh*'s engines as manufactured new from Richmond was made by a contraband named William Robins, who had

apparently been involved with construction (*Official Records of the Union and Confederate Navies in the War of the Rebellion* 1987 [Ser. 1, Vol. 8]:89).

There exists another significant possibility that *Raleigh's* engines came from an unfinished wooden gunboat built at Washington, North Carolina. This boat and two others were under construction in 1861 by Gilbert Elliott, later the builder of CSS *Albemarle*, and were approximately 150 feet long with a 25-foot beam (William Francis Martin Papers 1787-1884:493). All were destroyed before completion when Union forces began to move into coastal North Carolina.

The Washington gunboats and others like them required engines of similar size to *Raleigh's*. Although there is no direct evidence that these engines ended up on the ironclad, there is other circumstantial data. It is known that the engines for the 150-foot gunboats built (none were ever completed) in North Carolina and Florida were to be provided by Talbott & Brothers of Richmond, more commonly known as the Shockoe Foundry, with the Florida boats' engines of 26-inch cylinder diameter and 24-inch stroke (National Archives RG 365 [Confederate Treasury Department Records]:Entry 59). These measurements only roughly approximate those found on *Raleigh*. If the ironclad's engines came from a Washington gunboat, it is safe to assume that they were altered during construction. In contract work, the Confederate Navy seems to have given builders considerable leeway in interpreting specifications (A. Robert Holcombe, Jr. 2011, elec. comm.). Nothing can be stated with any certainty to date. Further investigation of *Raleigh's* well-preserved wreck in the Cape Fear River will likely be able to determine if Tredegar manufactured its engines or Talbott & Brothers built them for a wooden gunboat.

The source of *Raleigh's* boilers and auxiliary equipment seems clearer. Thomas E. Roberts established the Clarendon Iron Works of Wilmington early in the war, and manufactured

many iron components for ship construction. Roberts's firm was accordingly involved in wartime naval construction in Wilmington, although it did not have the capability for heavy forging. The Clarendon Works also "...cast a substantial quantity of boiler parts, including boiler iron, grate bars, flues, and fronts, suggesting that it built the boilers for the *Raleigh*..." (Combs 1993:63). Despite this ability to construct boilers, building marine steam engines was another task entirely for small foundries like Clarendon. The construction of engines often had to be outsourced. Most of the current confusion over machinery sources arises from this wartime necessity. Contradictory accounts only add to the problem, as with *CSS Albemarle*.

Several conflicting accounts of where *Albemarle*'s machinery came from exist. Robert Elliott (2005:141-142), author of the definitive *Ironclad of the Roanoke*, perhaps describes the conundrum best:

The former Commander of the Neuse, Benjamin F. Loyall, remarked on January 19, 1897, at the occasion of Robert E. Lee's birthday dinner in Norfolk that, 'the engine of a large saw mill was altered and made to serve for her [*Albemarle*'s] propelling power.'

A publication circa 1897, *Ironclads in Action*, mentioned in passing, 'The engines procured from the Tredegar Works, at Richmond, were two, each driving one screw, and had a nominal horsepower of 100 apiece.'

In addition, former Confederate officer (and author of the first complete history of the C.S. Navy) J. Thomas Scharf included a quote from one of *Albemarle*'s former commanders, John N. Maffitt: "The engine was adapted from incongruous material, ingeniously dovetailed and put together with a determined will..." (Scharf 1887:404). It seems unlikely that *Albemarle*'s machinery was built totally from scratch because the builders had difficulty finding even simple railroad rails for armor, let alone engine parts. The sawmill hypothesis is reasonable, but the mention of Tredegar throws all into doubt. Either way, the case is the same as that of *Raleigh*: the Tredegar works certainly had the ability to produce *Albemarle*'s engines and is known to

have provided the armor for the vessel. Unfortunately, the provenance of this famous ironclad's machinery will likely remain uncertain: *Albemarle* was broken up in 1867.

As previously stated, Tredegar had contracted to supply the machinery for the ironclads built in Richmond. The engine of the first warship to be completed there, CSS *Richmond*, was taken from the C.S. Receiving Ship *Arctic* (formerly a lightship) and was supplied and installed by Tredegar. The iron works also may have built the engines for *Virginia II* and *Fredericksburg*, but as the contract called only for supplying the engines construction may very well have been outsourced, particularly to the Confederate Naval Works.

Further confusion arises because at least one account suggests *Virginia II* may have had British machinery of unknown origin (Still 1994:67). In a 25 April 1865 survey of captured steam machinery, Commander William Radford, USN, listed "One pair of double engines, 30-inch cylinder and 28-inch stroke, high pressure and similar to those used on Ram Virginia [II]" (National Archives RG 45 [PN File]:Roll 42). Since Great Britain was the primary manufacturer of "double" or twin-cylinder engines by the 1860s, it appears likely that if *Virginia II* did indeed have two twin-cylinder engines, they were British-made.

So much uncertainty exists because many documents relating to naval construction were destroyed in the evacuation of Richmond on 2-3 April 1865. There remains little doubt that even if it did not construct whole engines, Joseph Anderson's Tredegar Iron Works contributed significantly to the installation of steam machinery in the Virginia and North Carolina ironclads, as it did to virtually every other wartime industry.

Columbus Naval Iron Works

The facilities for engine and shipbuilding in Columbus, Georgia, came to represent the second-greatest concentration of industry in the Confederacy. Skillfully managed and well-

furnished with necessary equipment, the Columbus Naval Iron Works manufactured complete sets of machinery for at least five ironclads and also refurbished old machinery for installation in new vessels. The Columbus works became the single most important Confederate source for purpose-built engines during the war, and was only exceeded in industrial output by Tredegar.

Ironclads known to have received Columbus-built machinery are *Savannah*, *Columbia*, *Jackson*, *Milledgeville*, and *Wilmington*. It is also possible that *Huntsville*, the sister ship of the Selma ironclad *Tuscaloosa*, received purpose-built machinery. Like *Tuscaloosa* it is far more likely that riverboat engines were scavenged and modified by the iron works for installation. Out of the vessels receiving purpose-built machinery from Columbus, only *Savannah* and *Columbia* were completed. The latter represented one of the South's finest engineering accomplishments, but was wrecked in Charleston Harbor soon after commissioning (Turner 1999:223). It would seem that the Columbus works failed almost completely to deliver on its promising potential, but these failures were the result of late-war circumstances and the usual labor problems. The Columbus Naval Iron Works in fact made great strides in advancing the marine steam engineering field in the Confederacy.

Columbus was located at the head of navigation on the Chattahoochee River and ideally suited for industrial development. Cotton and other agricultural products were shipped along the rivers, and a thriving steamboat building industry combined with cotton and wool mills turned the city into the most industrialized in the South behind Richmond (Turner 1999:9). It was there that a gentleman named William R. Brown established a small foundry, the Columbus Iron Works, on the lower town riverbank in 1848 (Standard 1954:40). This small establishment constructed steamboat engines, boilers, and fittings using only one rolling mill and forge.

Brown's works remained minor but accomplished until 1861 and the coming of war began to change everything.

By July 1861, Brown had begun turning out small cannon and accepted contracts from the Confederate Ordnance Department. In January 1862, the Columbus works successfully produced several types of weapon, including mortars and rifled cannon (Standard 1954:40-41). Noting the foundry's ideal site on the Chattahoochee riverbank, the Navy Department leased Brown's facility beginning in September 1862 (Turner 1999:149). Now the Columbus Naval Iron Works, the firm grew into a large naval industrial complex sending "...ships' machinery, ordnance, and engineering expertise throughout the Confederacy" (Turner 1999:154). The two men tasked with managing this operation were Lieutenant Augustus McLaughlin, CSN, who proved to be an able administrator and superintendent, and Chief Engineer James Warner, probably the Confederacy's most skilled engineer. Warner was put in charge of the machine shops in Columbus, and oversaw the manufacture and refurbishing of a large number of steam engines. His skill and unwavering work ethic led to the exponential growth of the Naval Iron Works during the war.

By 1865, the Columbus works had grown to become one of the largest in the Confederacy (Figure IV.2). The armory contained a small rolling mill, a nearly-complete large rolling mill, and one large steam hammer from Mobile. The machine shop contained: "three small and two large planers, sixteen iron lathes, one large lathe, three drill presses, ...[and] thirty vises...with anvils" (Turner 1999:236). Also present on the site were: a blacksmith shop with 10 forges, a foundry, a boiler shop, a copper shop, and a pattern shop. Entire sets of machinery were turned out along with a number of rebuilt engines. All of this was run by a force of over 300 men, with auxiliary facilities in Prattville and Eufaula, Alabama. Personnel from Columbus were

sent all over the Confederacy, and maintained offices in Charleston, Savannah, Selma, and Mobile, among others. These local outlets were often in charge of assembling and installing the batches of ironclad machinery sent from Columbus. For example, A.N. Miller's foundry in Savannah, discussed later in connection with CSS *Georgia*, was in charge of assembling and installing the machinery for the Savannah ironclads, including *Milledgeville* (Still 1989:9).

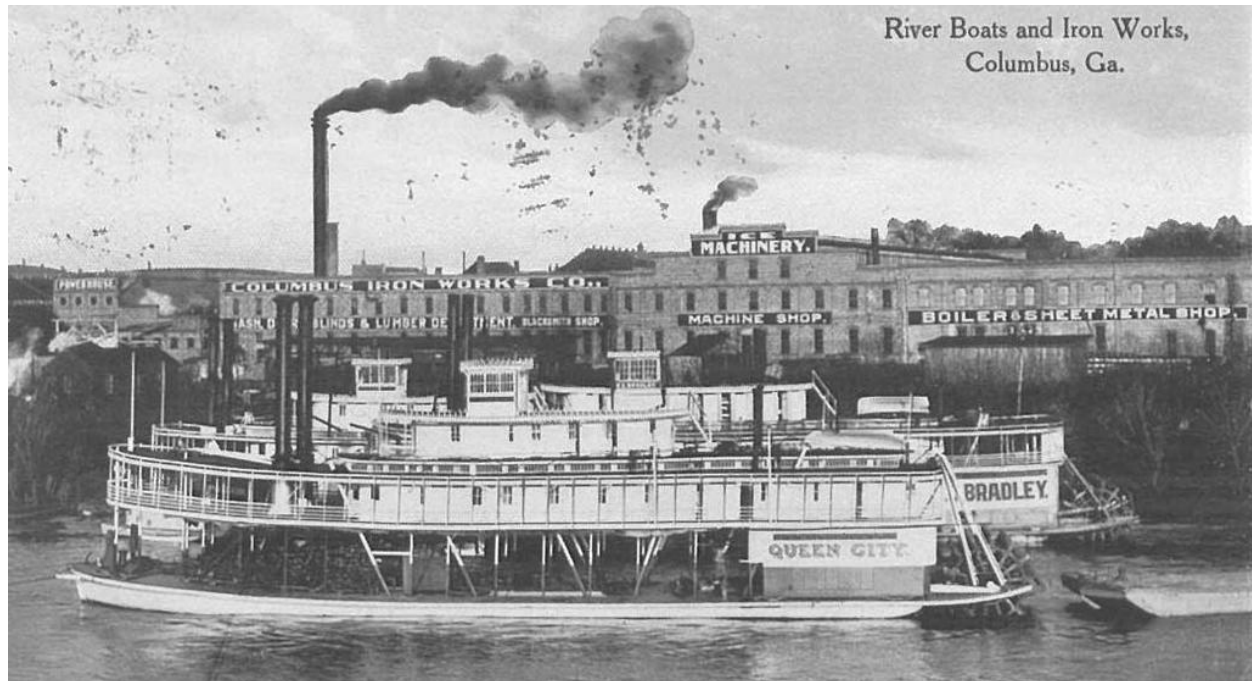

FIGURE IV.2. This 1910 postcard shows the exterior of the Columbus Iron Works and its ideal location next to the Chattahoochee River and steamboat landing. (Columbus Museum 2012; courtesy of Kenneth F. Murrah)

Columbus-built machinery for the *Richmond*-class ironclad *Savannah*, launched in 1863 in its namesake city, appears to have been originally intended for a 150-foot gunboat constructed by F.G. Howard at Milton, Florida. When the wooden gunboat program was superseded by ironclad construction, some engines were refitted for ironclads. Regarding the unfinished Florida gunboat, Secretary Mallory wrote to Warner on 10 April 1862:

You will take charge of this work at once, and are authorized to make such alterations and additions to the engines as will adapt it to one of the iron clad gun boats to be constructed by Mr. Willink [*Savannah's* builder]. (National Archives RG 45 [Area 8 File]:Frame 0258)

The vessel to which Mallory referred could only have been *Savannah*, since the other ironclad built by Willink, CSS *Milledgeville*, was not laid down until much later. Regardless, the machinery provided for *Savannah* reflected some of the early quality-control problems endemic to the steam engineering business, despite the skill of the Columbus establishment. While on a trial run, one of *Savannah*'s cylinders was broken by a rivet left in the steam passage (Turner 1999:165). This incident involving pure "human error" caused Engineer Warner considerable embarrassment, but the other purpose-built machinery supplied for *Columbia*, *Jackson*, *Milledgeville*, and *Wilmington* reflected the highest quality possible within the Confederacy. *Columbia* was the only one finished, as the machinery for the others was only partially assembled prior to their destruction at war's end.

Warranting brief discussion here are the ironclads *Jackson*, *Tuscaloosa*, and *Huntsville*. The former was originally constructed as a paddlewheeler, but had to be redesigned to accommodate twin-screw propulsion due to weight issues. *Jackson*'s original machinery was taken from the steamboat *Time*, but the new engines were manufactured in Columbus. *Tuscaloosa*'s engines were taken from the steamboat *Chewala* and reworked at Prattville, while almost nothing is known about *Huntsville*'s machinery other than that it was supplied by Columbus (Turner 1999:162). It appears likely that this ironclad's engines, which performed just as poorly as those on *Tuscaloosa*, were taken from a river steamer and reworked either at Columbus or Prattville. The 165-ton 1859 sidewheeler *John C. Calhoun* is a possible source of *Huntsville*'s machinery. This West Brownsville, Pennsylvania-built vessel exploded with loss of life near Bainbridge, Georgia, on 28 April 1862 (Way 1983:250; Mueller 1990:102). The machinery was salvaged and the Naval Iron Works made a breech-loading cannon from one of

Calhoun's shafts. The engines were also supposedly the same size as those from *Chewala* installed on *Tuscaloosa* (Daniel and Gunter 1977:34; Ripley 1984:181).

The Columbus Naval Iron Works enjoyed considerable success in procuring and building steam engines during the Civil War. It gathered and contributed a considerable amount of expertise in marine engineering in the South during that time. The Columbus works and its satellites in Prattville and Eufaula succeeded in providing power to a number of ironclads and wooden gunboats as well as manufacturing naval ordnance. For the most part, these vessels met with little success. Several were never completed due to Union captures of their home ports. Columbus itself was not captured until 16-17 April 1865, over a week after Appomattox. The Confederacy's second-largest industrial site continued with production up until the very end. In doing so it made a huge positive impact on the Confederate war effort. (Turner 1999:261-264)

Shockoe Foundry / Confederate Naval Works

The Shockoe Foundry in Richmond (formally called Talbott & Brothers) was closely tied to the Tredegar Iron Works in the manufacture of marine steam machinery. This facility produced small steam engines and sawmills before the war and was "...considered very good here [Richmond] for what they purchase, and in all our [Tredegar Iron Works] transactions with them they have been very prompt" (Bruce 1968:296). This large establishment was important in the manufacture of steam machinery in the Confederate capital, but little is known of its true output due to the destruction of its records at war's end.

By 1862 the Shockoe Foundry was over a full city block in size. It was located at 17th and Cary streets in Richmond. The large establishment consisted of a fitting shop, turning shop, smith's shop, foundry, drying oven, boiler room, and flash room (Coski 2005:72). By that time it

was only surpassed in size and output by neighboring Tredegar, which Shockoe often supplied with parts and materials.

First founded in 1839 as the Shockoe Manufacturing Company by former manager of the Seaboard and Roanoke Railroad Charles Talbott, the foundry remained prosperous through the 1850s with the growth of Virginia's railroads. The firm even began producing its own locomotives in 1855 (Bruce 1968:296-297). By 1862, the Talbott brother's excellent establishment earned the Shockoe Foundry a government contract to build engines for wooden gunboats. When this program fell through, power plants for ironclads were manufactured, but the extent of this new production is unknown.

In February 1862, the Confederate government stepped in and leased the Talbott's establishment in the name of the Navy as the Confederate Naval Works. Under the supervision of Thomas W. Smith, the foundry turned out wartime products for the rate of \$5,000 per month (Coski 2005:282-283). It is thought that these works produced several engines for ironclads, but the dearth of records has led to confusion over whether the Naval Works or Tredegar produced the machinery. It is possible that Tredegar, which was tasked with providing all the iron components of the James River ironclads, contracted with the Naval Works to build the engines. These establishments had worked closely together before, and the capability to produce excellent-quality parts of all types was certainly there.

Current research holds that the ironclads *Fredericksburg*, *Virginia II*, *Albemarle*, *Raleigh*, and several of the small wooden gunboats on the James River may have received all or part of their machinery from the Naval Works (Still 1994:68). In any event, it is clear that the former Shockoe Foundry played an important role in steam machinery construction in the Confederacy. Hopefully, this role can be more fully defined by future research.

Charlotte Navy Yard

The naval yard established inland at Charlotte, North Carolina, was an unlikely source of much of the machinery produced for the Confederate Navy. Founded in 1862 by wartime necessity, Charlotte ultimately produced the majority of the shafting used by propeller-driven ironclads. It also manufactured ordnance and other naval supplies, having an industrial capacity not easily matched by most other Southern military facilities. This was due to its close ties to Norfolk before that navy yard was re-captured by the Union. (Still 1997:76-79)

Donnelly (1959:73) states: “In the spring of 1862 it became apparent that the Confederacy stood a fair chance of losing the Norfolk area and, with it, the Gosport Navy Yard”. The hotly-contested base where USS *Merrimack* had been transformed into CSS *Virginia* was the largest such facility in the South, and the Union was keen on recapturing it. As the pressure around Norfolk tightened, brother of Robert E. Lee and yard commandant Captain Sidney Smith Lee was secretly ordered by Secretary Mallory to begin packing and preparing for transport all the valuable machinery and goods not immediately needed. Beginning in early May 1862, several trainloads of supplies were sent from Norfolk while others were shipped up the James River to Richmond (Donnelly 1959:73). Captain Richard L. Page, CSN, was simultaneously directed by Secretary Mallory to find a safe place in North Carolina for a new facility.

Charlotte was chosen as the ideal location of a new navy yard because it was deep in the interior but still had good railroad connections with the coastal cities. It came to pass that the Charlotte Navy Yard experienced less disruption by the enemy during the course of the war than any other naval works. The tools and materials shipped from Norfolk were quickly put to use, among them a small steam hammer. A new ordnance works was constructed along with various large structures for the shops, coke ovens, and foundry. The size and output of these facilities

increased continually during the war years. By summer 1862 a hoisting crane was in operation along with another steam hammer. This new hammer was quite large and had been saved from the Pensacola Navy Yard in Florida. The tracks of the North Carolina Central Railroad and the South Carolina Railroad passed close by the navy yard, allowing for simplified loading and unloading of new materials. Overseeing all of this was a force of over 1,000 men led by Captain George N. Hollins. He was replaced by Lieutenant Catesby ap Roger Jones of CSS *Virginia* fame, and he in turn by Chief Engineer H. Ashton Ramsay. All of these men performed their duties valiantly, but it was Ramsay who was in charge the longest and who saw the greatest expansion of the navy yard's facilities. (Donnelly 1959:74)

In 1863 the Charlotte yard was further enlarged and improved through the extending and strengthening of its buildings and the addition of new machinery. New pattern shops, a coppersmith shop, a new furnace, and a facility for inspecting projectiles were added at this time. In addition, the foundry was enlarged to accommodate a new steam hammer built at the yard—the largest in the South. This piece of equipment was capable of forging the heavy shafting and large anchors required by the ironclads then building elsewhere in the Confederacy. Along with all of the new developments in manufacturing iron components, the yard also continued to turn out gun carriages, blocks, and large amounts of ammunition. Many of these products were destined for service onboard ironclads as well. (Donnelly 1959:77)

Despite the tremendous capabilities of his establishment, Chief Engineer Ramsay encountered a lack of skilled labor for his workforce. This severely limited production. The great forges and planers of the Charlotte station were too often idle and many of the heavy forgings intended for new warships took too long to finish. All of these symptoms of a small labor pool were encountered by facilities elsewhere in the Confederacy. Attempts by Ramsay to recruit

skilled workers from Great Britain failed, and he spent much of the war on a minimum basis of production (Donnelly 1959:77).

By war's end, the Charlotte Navy Yard had nevertheless achieved some notable successes. One of the workers from Norfolk had invented a machine for turning a perfect sphere, "...a process particularly applicable in making cannon balls or shells" (Donnelly 1959:77). It was first used at Charlotte and was probably the first machine of its kind anywhere. Large sheds were built for storage of Confederate naval goods and a variety of large iron shafting for steamers was completed. The ironclads that received their shafting from the Charlotte works were *Virginia II*, *Albemarle*, *Tennessee*, and several others unspecified (Donnelly 1959:78). Heavy iron components were also provided for several wooden gunboats and a large amount of ammunition continued to be produced into the war's very last days.

Ultimately, the Charlotte Navy Yard was one of the very last Confederate military establishments to close down in 1865. After the evacuation of Richmond in April, the specie from the Confederate Treasury was sent first to Charlotte for a guard company to take it into the Trans-Mississippi Department. The yard was abandoned and burned not long after, marking the end of Confederate naval administration (Donnelly 1959:79). Sadly, the majority of the yard's records and many of those of the Navy Department itself were burned as well. American history lost a valuable collection of information in this hasty decision.

New Orleans Manufacturers

New Orleans contained the greatest manufacturing capability of any city in the South outside of Richmond prior to its capture in April 1862. The manufacture of steam machinery, particularly for riverboats, was a thriving business by the 1860s because the city was uniquely situated on the Mississippi to function both as a river and ocean port. New Orleans had many

private businesses devoted to the manufacture of steam engines. Foremost were "...the foundries of Leeds, Clark, Bennett & Lurgis, Shakespeare, Gretna, John Armstrong, and Kirk" (Merrill 1962:87). Abundant resources for shipbuilding existed in the area in addition to these establishments, and across the river in Algiers were eight drydocks. It appeared that ironclads constructed in the Crescent City could be built well and quickly.

The two ironclads actually laid down and constructed in New Orleans were the largest war machines built from the keel up in the Confederacy. *Louisiana* and *Mississippi* were laid down side by side at new shipyard sites just north of New Orleans at Jefferson City. During the course of their construction, materials for engines often came from the same sources. The builders of *Louisiana* and *Mississippi* turned to the largest and most respectable firms in the area: Leeds & Company and Patterson Iron Works (Merrill 1970:72).

Although the Leeds and Patterson works were nearly the same size, Leeds far exceeded any other New Orleans company in output and experience. Leeds & Company was founded in the 1820s and was the world's largest maker of steel cotton bale presses by the time of the Civil War. The establishment also had experience in casting, forging, and finishing iron components for sugar and cotton equipment and steam engines, employing a force of over 400 workers. During the war, production was shifted to manufacturing arms for the Confederate Army (Groundspeak, Inc. 2012). Leeds also agreed to make the shafts of two propeller-driven ironclads being built in Memphis, Tennessee, one of which was CSS *Arkansas*. The firm quickly became too busy to aid much in the vital work being carried out on the two large ironclads intended for the defense of New Orleans.

E.C. Murray's CSS *Louisiana* was the first to be laid down. The massive vessel was propelled by two central paddlewheels mounted one ahead of the other and two small propellers

under the stern. Two riverboat and two propeller engines needed to be procured. According to Murray's 20 February 1863 testimony during the 1862-1863 investigation of the Navy

Department:

I bought the steamer *Ingomar*, and transferred her machinery to the *Louisiana*. I...contracted with Kirk to build me two propellers and two propeller engines. Not being able to get them anywhere else, I applied to Leeds to construct them, but he would not touch them. They [Kirk] were engaged in removing the machinery from the *Ingomar* to the *Louisiana* about two months, and about the same time building her propeller machinery (CSA 1863:372).

The large riverboat *Ingomar* was built in 1854 at Louisville, Kentucky, for the Memphis & New Orleans Packet Company (Way 1983:224). Unlike many Western river steamboats, the name of who furnished its machinery is known: the Louisville firm of Roach & Long (CSA 1863:378). That establishment was founded in the 1840s and built many steamboat and stationary engines before turning exclusively to the manufacture of water and gas main pipes after 1860 (Kleber 2001:422).

The small engines and shafts required for the propellers had to be purpose-built in New Orleans. Leeds was too loaded down with wartime contracts to build any of *Louisiana's* machinery. Kirk & Company, a smaller establishment, ultimately agreed to furnish Murray his propeller engines and shafts. The history of this firm unfortunately remains obscure. Such is the case with most of those in New Orleans during the war.

It is worth noting that *Louisiana's* wrought iron shafts as finished did not fit properly. Murray had to persuade Kirk to construct a tilt hammer, "by which means he succeeded in drawing them out and adapting them to my purpose. The only difficulty I had was to get him to get along with the work" (CSA 1863:378). Despite the firm's slowness in turning out materials, it seems they had the machinery and capability to do the job. Kirk also made the small propeller engines but almost nothing is known about them. Little has been found on the company itself.

Patterson Iron Works (formally known as Jackson & Co.) agreed to furnish engines and boilers for Asa and Nelson Tift's giant triple-screw *Mississippi*. This was only after consultation with Leeds failed, as that company was occupied in manufacturing the shafting for *Arkansas* and the never-finished *Tennessee* in Memphis (CSA 1863:381). Leeds's asking price for constructing the engines of \$65,000 plus a build time of no less than four months was too steep for a short construction time. The Patterson works in turn offered to construct the machinery for \$45,000 plus a bonus if the work was finished in 90 days. A contract was signed and construction began. The Tifts discovered they had miscalculated the power needed to propel *Mississippi* not far into the process. Consultation with naval engineers and other experts revealed that more boilers were required. Patterson added \$20,000 in price for building the engines and \$8,000 for the boilers (Merrill 1962:90). Despite these difficulties, the greatest problems were encountered in the building of the ironclad's three propeller shafts.

Finding no complete shafts in the New Orleans area and "...no parties [there] ...competent to make it" (i.e. no one had a tilt hammer or other shaft making equipment), the Tifts contracted with Ward & Company of Nashville, Tennessee, to make the two wing shafts (CSA 1863:112). *Mississippi's* massive center shaft was to be forged by Tredegar out of the destroyed steamer *Glen Cove's* in Richmond. Negotiations with Ward about proper furnace and hammer equipment along with haggling over prices continued for some time but came to nothing. The Tifts next turned to Clark & Company of New Orleans, which agreed to do the work. Clark then constructed a large steam hammer and furnaces in a new building for the purpose (CSA 1863:112). Further negotiations with Leeds resulted in an agreement to finish the shafts once they had been forged and progress was finally made. All came to naught when New Orleans fell and *Mississippi* was burned.

Overall, it appears that the machinery manufactured by the various New Orleans firms for *Louisiana* and *Mississippi* was satisfactory but delayed severely by shortages of workers and materials. While this fact holds true for virtually every other manufacturing center in the Confederacy, New Orleans was affected catastrophically by its capture at the end of the first year of war. As Secretary Mallory had realized, there was great manufacturing potential in the South's largest port, but it took too long to build up to full wartime production. *Louisiana* was delayed too long for the defects in its propulsion system to be realized in time and *Mississippi* was destroyed in a nearly-complete state. This failure on the part of the New Orleans firms resulted in the premature loss of that city and the South's two most powerful ironclads. (Merrill 1962:93; Still 1997:30-31)

Other Sources

A number of vessels were fitted with scavenged engines taken from riverboats or manufactured by small local foundries due to the limited availability of suitable steam machinery for ironclads throughout the Civil War. Most of the history of these engine sources has been lost. Future archaeological investigation has the potential to uncover a great deal of information because many of these vessels were sunk.

Ironclad vessels known to have used riverboat machinery were *Tennessee*, *Nashville*, *Tuscaloosa*, *Missouri*, and *Jackson*. This was a measure of necessity despite the obvious disadvantages of using old or decrepit power plants or, in the case of *Tennessee* and *Tuscaloosa*, adapting high-pressure riverboat machinery to turn screws. It was intended that these vessels be fitted with better purpose-built engines once they became available but this optimistic plan was never fulfilled. The ironclads designed from the outset to be paddlewheelers fared somewhat better in engine performance but both *Nashville* and *Jackson* encountered severe weight

problems. The result was that *Jackson* was completely rebuilt as a twin-screw vessel and *Nashville* was so structurally weak that it could only carry three guns and very little armor. (Still 1987:38; Still 1994:66-67)

The power plants of these vessels were simple and rugged like the river steamboats they came from, but their construction history has largely been forgotten. In most cases, the names and locations are known but not the manufacturer. The Civil War came during the heyday of the steamboat era, when thousands of boats plied the Western waters and hundreds of local firms supplied their machinery. Often a boat was built in one place (Figure IV.3) then taken to another for fitting out and installation of machinery, making specific firms difficult to trace (Way 1983: Terms, Abbreviations, and Discussion). Discussion of the above-listed ironclad machinery is brief because of this.



FIGURE IV.3. Four “City-class” Union ironclad gunboats being constructed at St. Louis, Missouri prior to October 1861. They will be launched sideways into the river. The construction process for these ironclads was similar to that used for regular steamboats. (Online Library of Selected Images, Naval Historical Center, Department of the Navy, Washington, DC, 2012)

Most famous of the ironclads of this group is CSS *Tennessee*, constructed in Selma, Alabama. This vessel was designed to be powered by a single screw but serviceable engines

were lacking. Riverboat engines were installed and geared to the propeller shaft in a complicated manner that actually worked comparatively well in service (Still 1994:67). Often cited as the source of these engines and possibly the boilers is the steamer *Alonzo Child*, built in 1857 at Jeffersonville, Indiana and captured by the Confederates on the Yazoo River (Way 1983:16). The engines were later removed and installed in *Tennessee* according to a Union survey report (*Official Records, Navies* 1987 [Ser. 1, Vol. 21]:547-550).

Confusion arises because the dimensions of *Alonzo Child*'s engines do not match those given for *Tennessee* and the time of their removal does not coincide with installation of *Tennessee*'s power plant. It appears likely that the engines instead came from the steamer *Vicksburg*, built at New Albany, Indiana, in 1857. *Vicksburg* was taken into Confederate service as a troop transport but was rammed and sunk by USS *Queen of the West* on 2 February 1863. The Confederates managed to salvage the machinery. The dimensions given for *Vicksburg*'s engines and the time during which they were salvaged appear to show that they were used on *Tennessee* (Way 1983:468; Still 1985:191-192). It is also stated in a letter from a J.J. Brown to Union Secretary of War E.M. Stanton that the ironclad *Nashville*, building at the same time as *Tennessee*, was receiving its machinery from *Vicksburg* (*Official Records, Navies* 1987 [Ser. 1, Vol. 20]:735). This is an obvious mistake because the dimensions of *Vicksburg*'s engines do not match those of *Nashville*. In fact, *Tennessee* and *Nashville* were confused for one another in several Union reports. In any case, the identity of the manufacturers of both vessels' power plants is missing from the historical record.

CSS *Nashville* was one of the largest ironclads constructed in the South and the only one built from the keel up driven by sidewheels. The ship was built in Montgomery, Alabama, and finished in Mobile. The giant paddlewheels were greatly exposed to combat damage but

“Apparently the Navy Department believed that the ease with which high pressure, long stroke engines could be installed with few, if any, modifications outweighed the disadvantages...” (Holcombe 1993:82-83). *Nashville* never saw combat but its engines were apparently able to move the vessel effectively. The machinery reportedly came from a sunken steamer in Mississippi’s Yazoo River (*Official Records, Navies* 1987 [Ser. 1, Vol. 25]:653). This report confuses *Nashville* with *Tennessee* but it is clear from the details presented that the former received its engines from a riverboat. *Magenta*, a large sidewheeler built at New Albany, Indiana, in 1861 appears to be a likely source of *Nashville*’s machinery. This boat was taken up the Yazoo and burned on 14 July 1863, and the dimensions of both its boilers and engines closely match those reported on *Nashville* (Way 1983:302). The company that constructed *Magenta*’s machinery is not known.

Another possible candidate for the source of *Nashville*’s machinery is the steamer *Capitol*. This sidewheel packet was built at Jeffersonville, Indiana, in 1854 (Way 1983:71). *Capitol* gained fame for its speed and for aiding in the completion of CSS *Arkansas* at Yazoo City, Mississippi (Figure IV.4). Way (1983:71) mentions that “Her machinery was said to have been used in completing the ram, and her hoisting engines were made over into drilling machines, etc.”. The boat was burned to prevent capture at Liverpool, Mississippi, on 28 June 1862 and its machinery was successfully removed by the Confederates (Warner 1864:229; National Archives RG 45 [AC File]:Roll 6). *Capitol*’s machinery dimensions also match those of *Nashville*. The provenance is unknown.

Very little is known about CSS *Tuscaloosa*, one of a pair of diamond hull ironclads built in Selma, Alabama. The engines of this twin-screw vessel were adapted from the riverboat *Chewala* and modified by William Penny & Co., of Prattville, Alabama. This company was a

branch of the Columbus Naval Iron Works. Not much is known about William Penny & Co., but it seems to have been "...an outgrowth of Penny & Chadwick of Milton, Florida. When that area came under Union control in 1862, Penny apparently moved his works to Prattville, where it came under Confederate navy control" (Continental Eagle Corporation 2007). This facility presumably had a fair level of capability to operate as a Naval Works auxiliary.

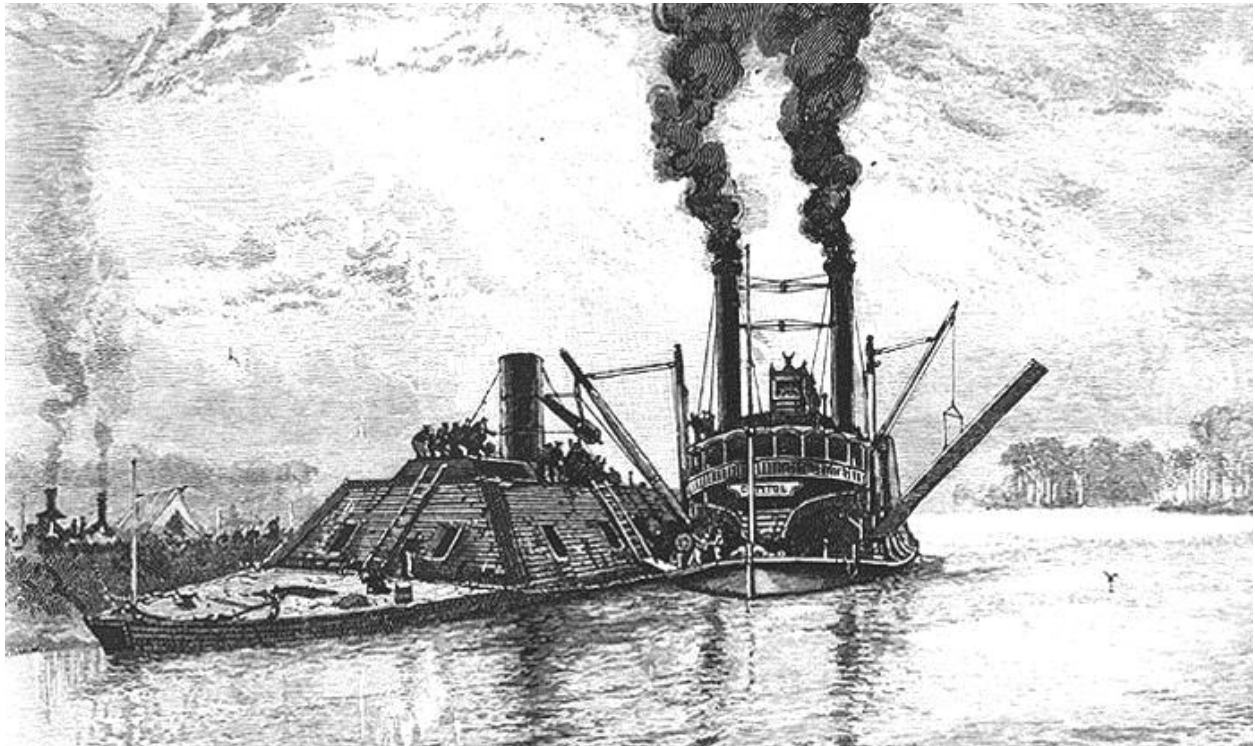

FIGURE IV.4. Construction of *Arkansas* at Yazoo City, Mississippi, in summer 1862. *Capitol* is shown alongside using its hoisting equipment to swing a gun onboard the ironclad. (*Battles and Leaders of the Civil War* 1991 [Vol. 3, Part 2]:573)

The manufacturer of *Chewala*'s machinery has not been found. This vessel was a sternwheeler built in Brownsville, Pennsylvania, in 1852. It served on the Apalachicola River before passing to Confederate control in 1861 (Neville 1961:38). The boat's machinery was later sold to the Columbus Naval Iron Works by that facility's former owner for \$2,000 (Turner 1999:162). This included *Chewala*'s boilers. The machinery formerly driving the sternwheel was installed using a geared layout to drive the twin screws of *Tuscaloosa* (Holcombe 1993:94).

CSS *Missouri* was the first of only two paddlewheel ironclads constructed from the keel up in the Confederacy. It was also the only centerwheel ironclad completed. This vessel was built in Shreveport, Louisiana, on the Red River to a similar design as the “City class” ironclad gunboats operated by the Union. Construction on the Western frontier was quite a challenge, but *Missouri* was furnished with fairly effective armor and motive power as reported by Union surveyors at war’s end. (Still 1985:101-102; Holcombe 1993:105-109)

There are two candidates for the source of *Missouri*’s power plant—both were river steamboats. The first is *Grand Era*, originally built at Louisville, Kentucky, as *R.W. McRea* in 1853. The vessel was rebuilt and renamed *Grand Era* after sale to the Red River Packet Co. in December 1860 (Way 1983:196,386). The second candidate is the sidewheeler *T.W. Roberts*, built in 1860 at New Albany, Indiana (Way 1983:443). Unfortunately, there are contradictory accounts regarding these two boats, both of which were operating around Shreveport at the time of *Missouri*’s construction (Way 1983:196,443; Silverstone 1989:247). Even though Way (1983:196) states that *Missouri*’s engines came from *Grand Era*, it is also suggested that *Grand Era* was operating from Shreveport to New Orleans after *Missouri*’s completion in late 1863. In addition, Jeter (1996:37) states (mistakenly?) that *T.W. Roberts* was renamed *New Era* based on correspondence suggesting that *New Era* be used to tow *Missouri* downriver for completion. Further contemporary correspondence in Jeter (1996:6) shows that the boat purchased for *Missouri*’s machinery was owned by Russell B. Roberts. The only steamboat that may fit the time and place for this is *T.W. Roberts* (A. Robert Holcombe, Jr. 2012, elec. comm.).

It is certain that in 1863, the naval officer in charge of *Missouri*’s construction, Lieutenant Jonathan H. Carter, purchased a boat’s engines and boilers for \$65,000 and an engineer was sent by the Navy Department to refurbish them. *Missouri* never saw battle and was

eventually captured, resulting in the aforementioned Union report. This report offers some of the most detailed machinery data on any Confederate ironclad, but the provenance of the power plant will remain unknown unless more conclusive information is found on the history and machinery of *Grand Era* and *T.W. Roberts*. (Still 1994:105)

The last Confederate ironclad definitely known to have used acquired riverboat machinery was *Jackson* (also commonly called *Muscogee*). This vessel was built in Columbus, Georgia, and was originally intended to be a centerwheel ironclad like *Missouri*. Realization of excessive weight and draft, along with a failed launch attempt, resulted in *Jackson*'s rebuilding into a twin-screw vessel (Holcombe 1993:109). The original steam propulsion machinery intended for *Jackson* came from the Chattahoochee River steamer *Time*, which was built in 1860 at Louisville, Kentucky. This steamboat was the last to enter service on the Apalachicola-Chattahoochee river system before the Civil War. It later came under Confederate control and may have had its name changed to *Bradford* (Pearce 2000:117). Conflicting accounts of *Time* / *Bradford*'s activities render a timeline difficult to establish. There is even evidence that *Time* and *Bradford* were separate boats but as late as March 1862 at least one of them was still operating (National Archives RG 109 [Microfilm Publication M909]:Roll 29).

At some point, *Time* was dismantled and its machinery appropriated for the ironclad building at Columbus. Everything was actually placed in *Jackson* and mostly put together before the need for a rebuild became apparent (Turner 1999:176). The provenance of *Time*'s power plant remains unknown, as is its fate after removal to make way for the Columbus-built propeller engines of *Jackson*'s second incarnation.

At least four other ironclads were completed using machinery from local machine shops with obscure or unknown histories. *Arkansas*, *Georgia*, *Charleston*, and *Neuse* were all

propeller-driven vessels (twin-screw except *Charleston*) but data on their machinery is lacking. *Arkansas* is perhaps the best-documented of this group due to its fame in running through a combined Union fleet to Vicksburg, Mississippi, on 15 July 1862. (Holcombe 1993:57,60,77-79; Bright et al. 1981:11-12,153)

The machinery for this vessel designed with both riverboat and seagoing elements was purpose-built in Memphis by a firm on Adams Street. Unfortunately there is some confusion as to the identity of the company. An 1860 Memphis city directory lists the Union Foundry & Machine Shop, but at least one other source lists *Arkansas*'s engines as coming from the foundry of S.M. Coates (Smith 2011:45). Almost nothing is known about these facilities; they may even just be different names of the same firm. More research must be done to clear up this mystery.

In addition to the engines and boilers produced in Memphis, *Arkansas*'s propeller shafts were forged and turned by Leeds in New Orleans. *Arkansas*'s power plant ultimately proved to be its greatest weakness despite the apparent superiority of its purpose-built independently operating engines. They directly caused the ironclad's loss through breakdown and scuttling in August 1862 (McClinton 1948:333). As with many other ironclads discussed, future archaeological investigation of the buried wreck has great potential to reveal new data.

CSS *Georgia*, a self-powered floating battery constructed in Savannah, remains to this day one of the most enigmatic Confederate ironclads despite extensive surveys of its wreck by the U.S. Army Corps of Engineers. It appears that the vessel was built to a simplified hull design with makeshift propulsion. According to Holcombe (1993:50), "The design of *Georgia* is attributed to A.N. Miller, a local foundryman with little practical experience in naval architecture". The floating battery may have been powered by machinery built or supplied by Miller due to its construction location next to Miller's foundry and machine shop. In a 2003

report, Mark Swanson and Robert Holcombe suggested that the engines came from the sidewheel steamer *William Jenkins*. This hypothesis has now been rendered invalid: "...recent archaeological evidence indicates the engines do not represent a beam engine, as was present on the *William Jenkins*" (Panamerican Consultants, Inc. [PCI] and Tidewater Atlantic Research [TAR] 2007:24). The engines are actually of the standard horizontal type, suggesting they may have been purpose-built. Miller's foundry certainly had the capability of producing these engines because he cast cylinders for a steam locomotive in the 1850s and manufactured at least one heavy weapon during the Civil War (PCI and TAR 2007:64). Apparently the foundry even operated as a local outlet for the Columbus Naval Iron Works (Still 1989:9). Another cited possibility is the machinery of the steamer *Emma*; unfortunately, no substantial information on this ship has been found (PCI and TAR 2007:64).

The third ironclad built at Charleston, South Carolina, was named in honor of that city. Almost nothing has been found relating to *Charleston's* machinery other than that the ship was driven by a single screw at a top speed of about six knots (Silverstone 2001:155). It seems likely that James M. Eason & Brother, the firm in charge of building *Charleston*, manufactured the power plant (Figure IV.5). This establishment certainly had the experience and capability.

The Eason foundry and machine shop was one of the oldest and largest industrial works in Charleston by the Civil War. It was founded sometime around 1819 as

...an outgrowth of a partnership between Thomas Dotterer and one Connor... A few years later Robert Eason entered the partnership, and by 1847 his two sons, James M. and Thomas D., were in control of the firm. (Lander 1960:333)

The foundry quickly grew into one of the most competent in Charleston and manufactured the first steam locomotive in South Carolina, the October 1830 "Best Friend of Charleston" as well as at least 10 others (Lander 1960:333-334). The establishment was manufacturing sawmill

engines and dredging Charleston Harbor with a specially-built dredge boat by the 1850s. Under the direction of the Eason brothers, the foundry had expanded to include “...cupola furnaces, forges, lathes, cranes, vises, drills, and saws. One of their special machines was a \$6,000 lathe made to order in Scotland and claimed to be the most powerful in the South. It could turn and finish a flywheel up to twelve feet in diameter” (Lander 1960:334). If this establishment, which was in charge of building every other part of the powerful *Charleston*, was not capable of producing its machinery, none other in South Carolina was. Nothing conclusive can be stated until more information comes to light.

J. M. Eason & Brother.

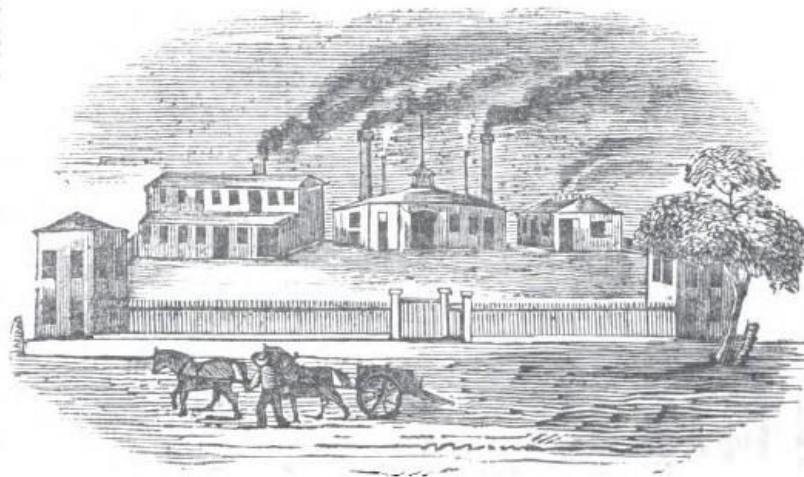

FOUNDRY & MACHINE SHOPS.

FIGURE IV.5. Advertisement for J.M. Eason & Brother, Charleston’s largest Civil War iron works and builder of CSS *Charleston* (VintageMachinery.org 2012)

CSS *Neuse* was a sister ship of the famous *Albemarle*. It is included as the last vessel in this section because of the extremely makeshift nature of its power plant. The one 15-foot boiler that powered the ironclad was taken from a “mud digger” steam locomotive owned by the Baltimore & Ohio Railroad: No. 34 “Gladiator” (Figure IV.6). The exact provenance of the

engines is uncertain because several sources have been listed. Among these are Pugh's Mill (presumably a sawmill) located in New Bern, North Carolina (Bright et al. 1981:12). Other possible sources are the Confederate Naval Works in Richmond and the cylinders of a steam locomotive (Still 1994:67-68). It seems likely that *Neuse's* machinery reflected a combination of these sources. Since the vessel's boiler came from a steam locomotive, it stands to reason that other useful parts such as the cylinders would have been scavenged as well. Perhaps auxiliary equipment was furnished from Richmond.

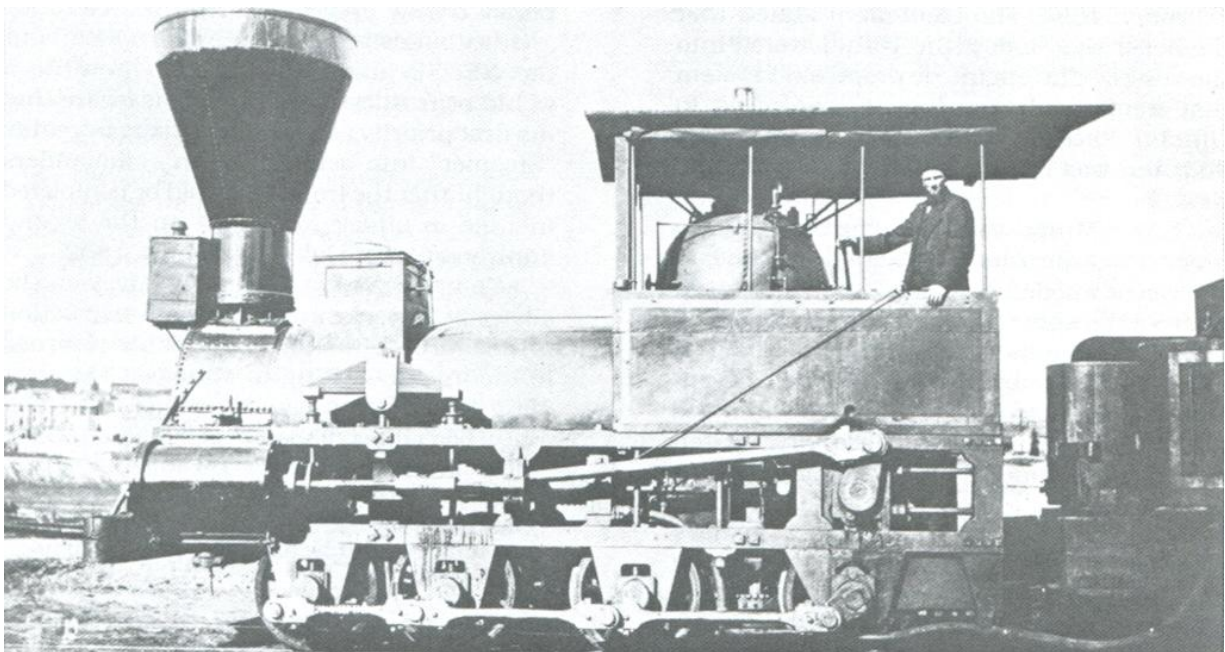

FIGURE IV.6. Baltimore & Ohio No. 37, a sister locomotive to No. 34, from which the boiler and probably cylinders were taken for CSS *Neuse* (Bright et al. 1981:11; courtesy of Smithsonian Institution)

Neuse spent its wartime career bottled up near Kinston, North Carolina, and was eventually scuttled. The machinery seems have been removed after the war by New Bern treasury representative William Heaton. He was able to auction *Neuse's* machinery to the New York firm of Satterlee & Lyon for \$3,500 (Campbell 2009:58). The auction advertisement in the 3 October 1865 edition of *The North Carolina Gazette* listed two engines, one donkey engine, and a boiler (Campbell 2009:58).

Another story concerning the removal of machinery from the wreck states that it was taken by a Captain Joseph M. White for use in his Kinston sawmill. Supposedly, White received government permission for the salvage and later sold the machinery to O’Berry Manufacturing Company in Kinston (Bright et al. 1981:153). No positive documentation concerning this turn of events has been found to date.

Northern-Built

A number of Confederate ironclads received at least part of their power plants from Northern manufacturers. Three of these vessels, *Manassas*, *Virginia*, and *Baltic*, were converted into armored warships from Northern-built hulls and machinery. Four of the purpose-built *Richmond*-class ironclads had to make do with engines removed from Northern vessels, while local firms supplied their boilers and other machinery. It would seem that power plants manufactured by the great engine works of the North would have been quite successful. In truth the utilization of these systems was for the most part unsatisfactory.

CSS *Manassas* was the first ironclad to be completed in the South. This small warship was converted from the powerful twin-screw towboat *Enoch Train* which had been built at Medford, Massachusetts, in 1855. Loring’s large City Point Works of Boston furnished the machinery while the hull itself was constructed by famed clipper ship builder J.O. Curtis (Silverstone 2001:152). This facility had achieved a national reputation for excellence in steam machinery by the time of the Civil War.

City Point’s founder, Harrison Loring, had established a machine and boiler shop in South Boston in 1847. The business grew and prospered. Ten years later Loring purchased land along the waterfront for a combined shipyard-machinery firm (Figure IV.7). This became the City Point Works, “...one of the first shipyards in the United States devoted to the construction

of iron steamships, engines, and boilers” (Mystic Seaport Manuscript Collection Registers 2012). Loring’s skilled establishment turned out several merchant ships before the Civil War and produced machinery for a number of others, including *Enoch Train*. During the war, two monitors and three sloops of war were constructed there. Admiral David G. Farragut’s famous flagship USS *Hartford* also received its machinery from these works.

IRON SHIP BUILDING.



HARRISON LORING,
CITY POINT WORKS, SOUTH BOSTON,
BUILDER OF

Iron Steamships; Stationary and Marine Engines; Boiler
and Tank Work, of every description; Sugar-Cane
Mills; Pumps; Presses; Shafting, and all
kinds of Mill-Gearing.

ALSO,

Loring’s Improved Revolving Bleaching Boilers, for Paper-Mills.

The conveniences and facilities at the CITY POINT WORKS, for the above work, are not surpassed in America; having a water-front of five hundred and fifty feet, and seven acres of land, upon which are erected two large Ship-Houses, in immediate connection with the extensive Boiler, Blacksmith, and Machine Shops, which are supplied with the best tools in the country.

Having a Pier over seven hundred feet long, can offer great inducements in repairing Steamships, and other marine work, in the most efficient manner, and with great dispatch; and will further state, to persons desiring to examine my Works, that the Iron Steamships SOUTH CAROLINA and MASSACHUSETTS, and the machinery of U. S. sloop-of-war HARTFORD, are some of my recent construction.

Thankful for the liberal patronage heretofore bestowed, I hope by strict personal attention to insure its continuance.

OFFICE AT THE WORKS.

BOSTON, July 7, 1860.

FIGURE IV.7. Advertisement for Loring’s City Point Works of South Boston, one of the largest iron shipbuilders in the United States by the 1860s (Courtesy of John Pike 2011)

The machinery built by City Point was highly praised (Bishop 1864:664-665). This was actually a major reason for *Enoch Train*'s conversion into an ironclad. The powerful towboat had independent twin-screw propulsion and, it was thought, more than enough power to function as a ram. This was true for the wooden *Enoch Train* but as *Manassas* the vessel suffered from the same defect of most ironclads: lack of power caused by the mounting of heavy armor and guns.

The original *Virginia* (ex-USS *Merrimack*) was the second Confederate ironclad completed and by far the most famous. This massive vessel had started its career as the first U.S. steam frigate, built at the Boston Navy Yard in 1854-1855. *Merrimack*'s massive engines were designed primarily "...to provide auxiliary power for the sails and to simplify maneuvering in and out of ports" (Park 2007:48). The power plant was built by the West Point Foundry of Cold Springs, New York, a highly-qualified government contractor.

The West Point Iron and Cannon Factory was founded in 1818 by the first graduate of West Point Military Academy, General Joseph Swift, with financial backing from a group of New York businessmen. It was supervised beginning in 1829 by the inventor of the Parrott rifle, Robert P. Parrott, and soon came to specialize in producing steam engines. By 1851 over 400 men worked there and an iron foundry, brass foundry, pattern shop, smith's shop, machine shop, and boiler shop comprised the sprawling complex (Figure IV.8). All of the equipment necessary for producing steam machinery was present: 3 furnaces, one 7-ton trip hammer, 2 tilt hammers, 28 turning lathes, and 3 planing machines. This was the source of *Merrimack*'s propeller and shaft, four upright boilers, and steam engines. The boilers were of the vertical watertube type designed by U.S. Navy Engineer-in-Chief Daniel B. Martin while the huge steam engines were designed by West Point superintendent Parrott himself. Such an impressive collection of quality machinery and talent seemed to guarantee excellence, but the U.S. maritime steam engine

industry was still in its infancy in the 1850s. The engines of *Merrimack* were weak and unreliable even into the ship's last days as the world-famous CSS *Virginia*. West Point itself had far more success during the war in crafting artillery pieces and shells. The foundry even received a congratulatory visit from President Lincoln in 1862. (Bathe 1951:4; Hillery 1961:1)



FIGURE IV.8. West Point Foundry, manufacturer of steam engines, boilers, and the Parrott rifle (Hillery 1961)

One of the most obscure Confederate ironclads is the converted sidewheel towboat CSS *Baltic* of Mobile, Alabama. This leaky and underpowered ironclad was originally built for the Southern Steamship Company in 1854 at Philadelphia. Very little is known of its construction specifications or construction history. Data on the manufacturer of *Baltic*'s engines is entirely lacking, but the power plant was typical for a paddlewheel-driven ship. Unfortunately, it was not capable of moving *Baltic* at more than a man's walking pace after conversion (*Official Records, Navies* 1987 [Ser. 1, Vol. 19]:198-200).

Several of the *Richmond*-class ironclads received their power plants from other vessels. Although these ironclads were purpose-built and designed by Confederate Chief Naval Constructor John L. Porter, a lack of suitable engines led to scavenged machinery for four of them. The first ironclad in this class was *CSS Richmond*, laid down at the Gosport Navy Yard in Norfolk and finished at Richmond in 1862. *Richmond*'s design was a significant improvement over the monstrous *Virginia* but its steam machinery was weak and reportedly removed from a former lightship, *USS Arctic* (Holcombe 1978:17).

The history of *Arctic* is somewhat murky. This is largely due to an error in the records unaccountably confusing *Arctic* with the paddlewheeler *Thomas G. Haight* (Heyl [4] 1953:14). What is known is that this vessel was built at the Philadelphia Navy Yard in 1855 and worked for a time as a Coast Survey ship exploring northern waters and along the Eastern Seaboard. *Arctic* was propelled by a single screw but the manufacturer of the machinery is unknown. A drawing of this vessel is shown in Figure IV.9. By the time of the Civil War, *Arctic* was serving at Frying Pan Shoals as *Lightship No. 8*. It had served in this station since 1859. Reportedly, the vessel's original machinery was removed for this duty, leading to more confusion about the source of *Richmond*'s engine. *Arctic* itself was overhauled in April 1861 at Wilmington, North Carolina, and served in that station throughout the Civil War as a receiving ship and ironclad floating battery (Combs 1996:3). During this time it may have received a new power plant or had its original one reinstalled.

Currently, the provenance of the machinery used for *Richmond* is unknown—it came from *Arctic* but may not have been original to that vessel. Its engine, whether original or not, was apparently obtained at the Gosport (Norfolk) Navy Yard after its capture by the Confederates (A. Robert Holcombe, Jr. 2012, elec. comm.). It was probably the single-cylinder vertical type

commonly used in small steamers. *Richmond*'s boilers were brand new and built at either the Tredegar Iron Works or Shockoe Foundry (Confederate Naval Works). Tredegar was in charge of installing them, but little could be done to increase the power plant's efficiency. This machinery proved too weak to efficiently propel *Richmond*.

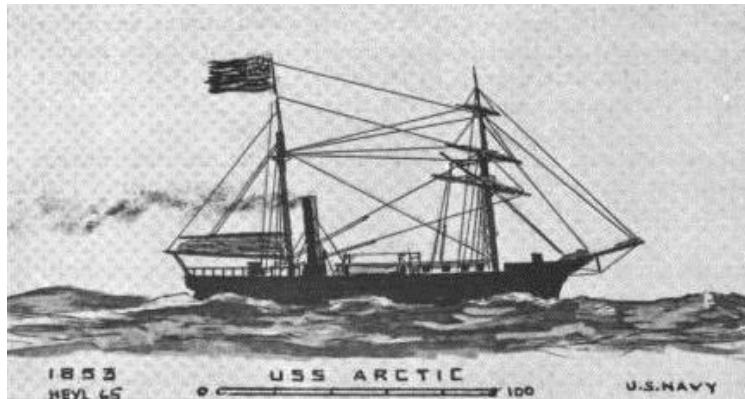

FIGURE IV.9. USS *Arctic* as drawn by Erik Heyl, representing its appearance as a coast survey vessel. (Heyl [4] 1953:13)

CSS *Chicora* was the next ironclad of the class to be completed. It was constructed and finished at Charleston, South Carolina, in 1862. Its engine was taken from the steam tug *Aid* (also listed as *Concord*, possibly a yard name). The boilers and other auxiliary equipment were furnished by James M. Eason & Brother, *Chicora*'s builder. *Aid*'s engine served *Chicora* well when it was installed in late 1862, but like almost all ironclad engines it was underpowered for the size of the ship. *Chicora* could not make over seven knots in the most favorable circumstances. (Mariners' Museum MS102 [Folder 4]:94; Campbell 2005:54-55)

Fortunately, a document presenting *Aid*'s hull and machinery dimensions has been preserved at The Mariners' Museum at Newport News, Virginia. Most importantly, its engine is listed as the typical vertical single-cylinder design of most tugs. This system was durable and simple like the vessels it served. *Aid* itself was apparently launched in August 1852 at Kensington, Pennsylvania and taken to Philadelphia for machinery installation. The builder of

the machinery was Reaney, Neafie & Co., one of the largest iron ship manufacturers in the United States. (Mariners' Museum MS102 [Folder 4]:94; Lytle and Holdcamper 1975:4)

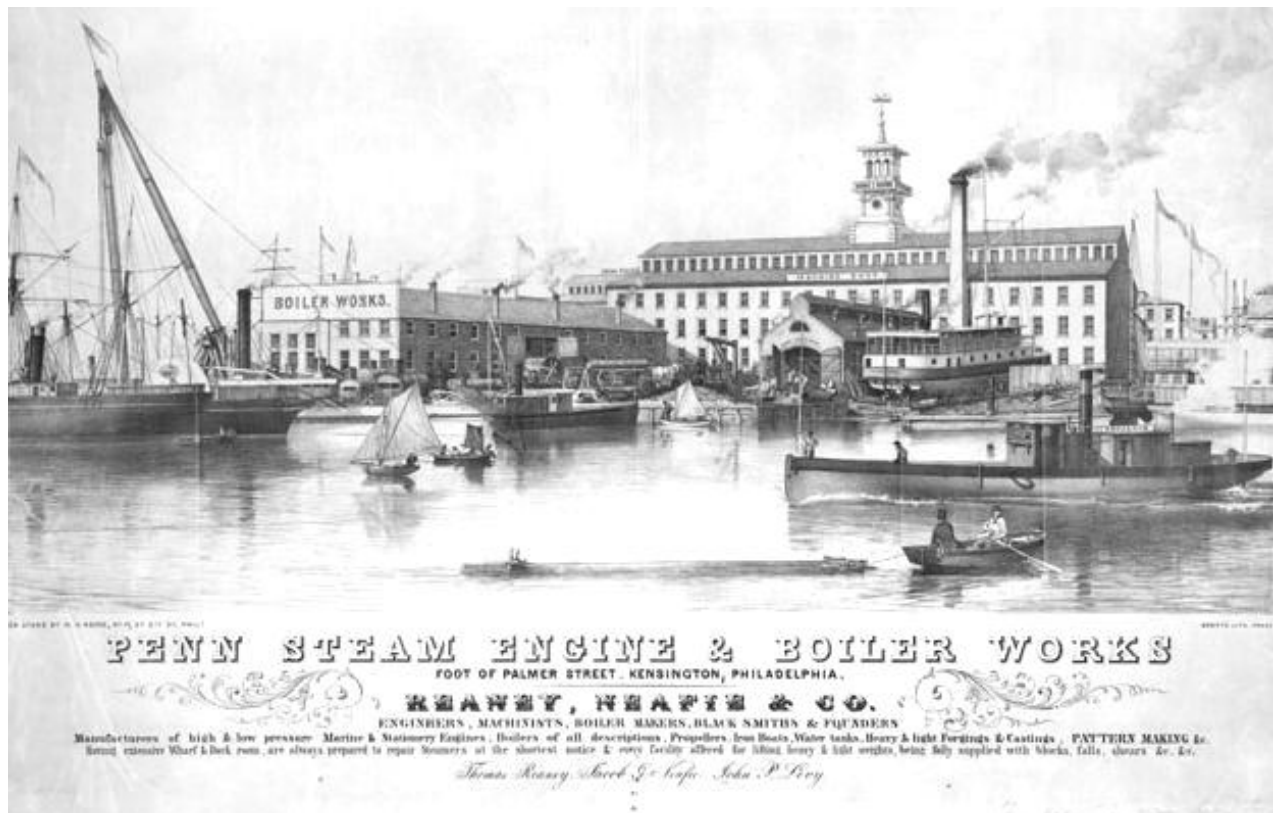

FIGURE IV.10. Advertisement for Reaney, Neafie & Co.’s Penn Steam Engine and Boiler Works in Philadelphia circa 1854, the largest builder of propeller-driven ships in the United States by the time of the Civil War (ExplorePAhistory.com 2011; courtesy of the Library Company of Philadelphia)

The giant establishment commonly known as the “Penn Works” was started in 1838 by Jacob G. Neafie on the corner of Germantown Road and Second Street in Philadelphia. Gradually, Neafie’s small collection of wooden sheds and small shops grew into one of the largest shipbuilding and machinery manufacturers in the North. Extensive works covering nearly 10 acres contained nearly every type of equipment necessary for building engines, boilers, and iron vessels (Figure IV.10). Engines were completed for many merchant vessels and warships of all types, including the frigate USS *Lancaster* and several gunboats. During the Civil War, “...the engines for about one hundred and twenty vessels, of all classes, were built here, some of

them among the largest in the service” (Bishop 1868:68-69). A large part of this success was due to the company’s extensive experience in forging propellers (Duffield 1896:5-6). By 1856, Reaney & Neafie had built more propeller engines than any other manufacturer in the United States, and even had the patent rights for the “curved propeller.” This was the originator of most modern propeller designs (Freedley 1856:295).

The Charleston-built ironclad *Palmetto State* also had single-cylinder tugboat machinery like its sister *Chicora*, but was equipped with two horizontal engines. These were taken from the small gunboat *Lady Davis*, formerly the Richmond iron-hulled tug *James Gray* (Figure IV.11). This single-screw vessel, also known by the possible yard name *Tompkins*, was built in 1857 at Philadelphia (Mariners’ Museum MS102 [Folder 5]:211). Again, the builder of this ship and its engines was Reaney, Neafie & Company. *Palmetto State* was like *Chicora*: reliable but underpowered. Its twin single-cylinder engines were certainly a more powerful system than that on *Chicora*, but were still too weak to speedily propel a heavy 175-foot long ironclad. The rest of *Palmetto State*’s machinery was manufactured and installed by Cameron & Co., a large Charleston foundry exceeded in size and output only by the Eason establishment.

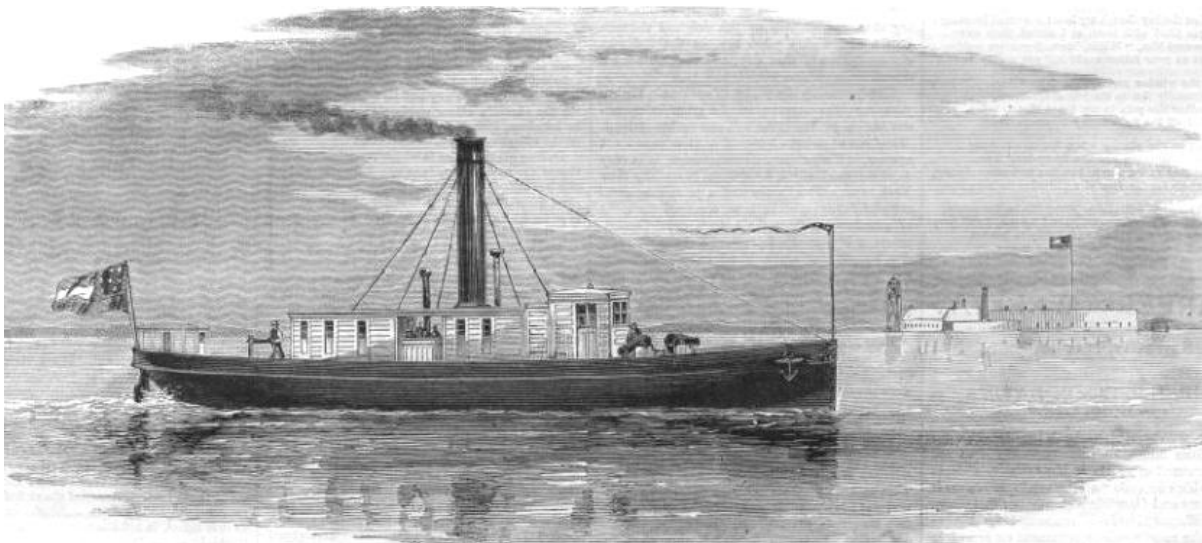

FIGURE IV.11. Confederate gunboat CSS *Lady Davis*, formerly *James Gray*, an iron-hulled tug built in Philadelphia (Son of the South 2008; from Harper’s Weekly 1861)

Cameron & Co. was widely known as the Phoenix Iron Works after a major rebuild following a fire in 1850. Its origins actually dated back to John Johnson's "air furnace" of 1802. By 1860, the Phoenix works consisted of a two-furnace foundry and carpenter, pattern, boiler making, finishing, and machine shops fitted with all the latest equipment (Lander 1960:332). When Archibald Cameron acquired control of the company early in the war, the iron works could boast of having manufactured steam engines, drydock components, and contracted work with the Charleston and Savannah Railroad (Wexler 2008:14).

The final ironclad known to have received its engine from a Northern-built ship was CSS *North Carolina*. It was a *Richmond*-class ironclad built from 1862 to 1863 at Wilmington, North Carolina. The engine for this poorly-constructed vessel was taken from the former Lake Erie tugboat *Uncle Ben*, which was used as a small gunboat on the Cape Fear River. *Uncle Ben* was earlier chartered in New York for a diplomatic expedition to Charleston on 9 April 1861. Unaware of the events at Fort Sumter on 12-13 April, the small tug had to put into Wilmington for repairs and was captured by Confederate forces (Combs 1996:1-2).

Uncle Ben was built in 1858 by the firm of Bidwell and Banta of Buffalo, New York. This shipyard was established in 1808 by Nathan Bidwell, but was burned by the British during the War of 1812. Bidwell quickly rebuilt, turning out the first steamship on the upper Great Lakes in 1818. In 1836, he partnered with J.W. Banta and the yard grew to include a marine railway and the first stationary dry dock on the Great Lakes. By the 1850s, the facility was one of the largest on the Lakes, turning out "...lavish 'palace steamers' and literally dozens of schooners and other steamboats..." (SS *Canandiana* 2012). *Uncle Ben* was one of these vessels, built to serve the yard and the city of Buffalo in general.

North Carolina's boilers, shafting, and auxiliary machinery were manufactured and installed by the Hart & Bailey Iron Works of Wilmington. This large facility had first opened under the name of Polley & Hart in 1840 as a manufacturer of copper stills for the Cape Fear area's turpentine industry (Combs 1993:61). The company was joined in 1857 by machinist John C. Bailey after expanding through the 1850s and branching into iron work. By 1860, production had further shifted away from copper and Hart & Bailey supplied Wilmington with much of its ironwork along with repairing machinery and building pump engines. The works included several machine, pattern, and copper shops along with a foundry.

Throughout the Civil War, Hart & Bailey was heavily involved with ship construction. Everything from bolts and machinery parts to complete boilers was produced (Combs 1993:62). This Wilmington establishment was one of the few works in the Confederacy capable of heavy forging and was accordingly able to rework components from *Uncle Ben* into what appeared to be a sufficient propulsion system for *North Carolina*. Ultimately, the ironclad proved to be the worst of the *Richmond*-class and indeed the most poorly-constructed in the Confederacy. This was due in no small part to the worn-out engine taken from *Uncle Ben*. Because of its extremely weak motive power, *North Carolina* could make no more than two or three knots and consequently became an easy target for shipworms. This last example of a Confederate ironclad with a Northern-built engine emphasizes best of all the unsatisfactory nature of scavenged power plants, no matter how well-constructed they may have been.

Conclusions

In conclusion, the sheer variety of ironclad power plant sources can be readily seen. Attempts at effectively powering Southern ironclads were unsuccessful for the most part. There were some noted instances of effective propulsion but these largely came late in the war from the

Columbus Naval Iron Works. Virtually all the other power plants procured that were not purpose-built had serious weaknesses. In the end, the assortment of machinery used for the ironclads represented a fairly complete cross-section of American marine steam engine industry.

Many manufacturers have mostly faded from the historical record, especially those in the river steamboat industry. Others, such as the great Northern shipyards, made huge impacts on the development of modern American shipbuilding. Northern-built engines usually were insufficient to power heavily-armored vessels due to their secondhand or worn-out nature, despite their often higher quality. None of the ironclads with Northern engines had very effective motive power, except perhaps *Manassas*. The Confederacy had greater success in making purpose-built engines for such vessels as *Columbia* and *Savannah*. Many of these never had the chance to be proven. Southern engine makers such as Tredegar and the Columbus works were kept busy during the Civil War but they met with limited success due to unavailability of materials, labor, and experience. Despite the rapid gain of such experience during the course of the conflict, it reached a competent level too late to make an appreciable difference for the South.

CHAPTER 5: IRONCLAD ENGINES IN PRACTICE—FIRSTHAND ACCOUNTS

Some of the most important facets of studying Confederate marine steam engines are the firsthand accounts of engineers, but it seems that this source of information has never been significantly utilized. The various accounts of the engineers and commanders of Confederate ironclads in service offer a perspective on the actual performance of steam engines in battle or general service, making an interesting comparison of theory versus practice. The operation of various engines can be observed in this manner, such as secondhand power plants versus purpose-built ones. A glimpse into the daily lives of an ironclad's crew members can also be achieved. The extraordinary circumstances these men commonly found themselves working in often lend their words great weight. This historical perspective puts a human face on the Confederate ironclad program and brings the momentous events of the 1860s closer to home.

Memoirs and histories subsequently published by various Union and Confederate commanders after the war rarely mention any machinery details, but accounts by engineers and others are common enough for a meaningful story to be told. These documents or articles are not as rare as commonly thought, although by no means are all Confederate ironclads discussed equally. Consequently, only a few vessels are represented, while many others are not at all.

In presenting these accounts, some context is needed. Therefore, the recounting here will offer brief explanations in addition to raw quotes, putting them in proper perspective. The relevant ironclads and events will be presented in chronological order. Detailed technical data not offered by these accounts will be presented in the following chapter.

Regarding CSS *Manassas*

There was one armored vessel which came before *Virginia*: the small twin-screw *Manassas*, converted into an armored privateer from the Massachusetts towboat *Enoch Train*.

The conversion was led by Captain John A. Stevenson at Algiers, Louisiana, and begun in May 1861 (Campbell 2006:48). The completed ship was seized in September 1861 by Confederate Navy forces in an attempt to bolster the defenses of New Orleans. The captain of the now-Confederate States Ship *Manassas* was Lieutenant Alexander F. Warley. He was displeased with his new command: he described *Manassas* as a "...bug-bear...no power, no speed, no strength of resistance and no armament" (Campbell 2006:49). In reality, the little ship was armed with one forward-firing gun, but its primary weapon was a ram. Unfortunately, *Manassas*'s speed for ramming was severely limited by its heavy armor and conditions in the machinery space were nearly intolerable—temperatures were reported at over 130° Fahrenheit. This problem was encountered onboard many other ironclads as well.

Warley was forced to take his new charge into action almost immediately, at the Head of the Passes on 12 October 1861. No firsthand engineering accounts of this battle are known to exist. *Manassas*'s master wrote instead on the second and final of his ship's fights, the Battle of Forts Jackson and St. Philip on 24 April 1862.

The account of Lieutenant Warley, published in Volume 1, Part 2 of *Battles and Leaders of the Civil War*, is brief but informative. It relates not just *Manassas*'s maneuvers and problems during the battle, but offers a glimpse into what it must have been like to serve on such a warship during the Union's climactic bid to approach and take New Orleans. Regarding the performance of *Manassas* during one of its ramming runs during the battle, Warley wrote:

The *Manassas* was driven at her [USS *Brooklyn*] with everything open, resin being piled into the furnaces. The gun was discharged when close on board. We struck her fairly amidship; the gun recoiled and turned over and remained there, the boiler started, slightly jamming the Chief Engineer, Dearing, but settled back as the vessel backed off. (*Battles and Leaders* 1991 [Vol. 2, Part 1]:90)

By this point in the fight, *Manassas*'s machinery was literally coming off its bedplates from the shock of heavy ramming. The ironclad had already hit USS *Mississippi* on the way down to meet the rest of the Union fleet. Unfortunately for the Confederates, neither ramming event did enough damage to sink the target vessel.

Following the nearly-disastrous encounter with *Brooklyn*, Warley took his battered ship back upstream, witnessing the utter defeat of the Confederate fleet on the way. He wrote:

Steaming slowly up the river—very slow was our best... The *Manassas* was helpless. She had nothing to fight with, and no speed to run with. I ordered her to be run into the bank on the Fort St. Philip side, her delivery-pipes to be cut, and the crew to be sent into the swamp through the elongated port forward, through which the gun had been used. (*Battles and Leaders* 1991 [Vol. 2, Part 1]:91)

After the abandonment, Federal sailors reached the stricken hulk and set fire to it. The burning wreck dislodged from the bank and drifted downriver as several Union ships poured broadsides into the thin iron shield (Campbell 2006:52). Finally, the battered, burned, and punctured little ship (Figure V.1) blew up and sank. So ended the first ironclad completed in North America.

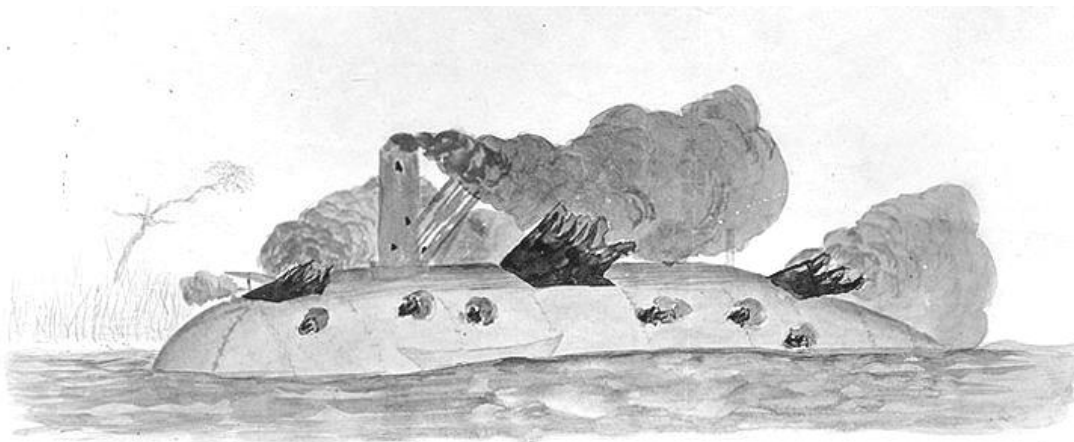

"The Ram as she appeared in passing the "Harriet Lane" after the "Mississippi" had got through with her."

FIGURE V.1. The final moments of CSS *Manassas*; the text below the image reads: "The Ram as she appeared in passing the 'Harriet Lane' after the 'Mississippi' had got through with her."

(Online Library of Selected Images, Naval Historical Center, Department of the Navy, Washington, DC, 2012)

Regarding CSS *Virginia*

The most famous Confederate ironclad was of course CSS *Virginia* (ex-USS *Merrimack*). Although the small ram *Manassas* was technically the first North American ironclad to be completed, it did not make the kind of lasting impressions on Confederate ironclad design as *Virginia*. Due to the fame and significance of *Virginia*'s battles, there exist a number of sources relating to the construction process and life onboard that vessel.

It is well-known that prior to its conversion to the prototype Confederate ironclad, *Virginia* had served as the first United States steam frigate, *Merrimack*, since 1855. During its service life, its engines were unable to propel the vessel at speeds of over eight knots. They were also inefficient and too lightly-built to turn the massive screw without trouble (Bathe 1951:5). The design problems and overall unsuitability of the engines were widely known prior to the destruction of *Merrimack* in spring 1861. Benjamin F. Isherwood, Engineer-in-Chief of the U.S. Navy from 1861 to 1869, stated in an 1863 report that:

The enormous cylinder capacity [72-inch diameter by 36-inch piston stroke] caused the steam to have a low average pressure on the pistons throughout the stroke, and the vacuum, owing to air leaks, was very poor. The arrangement and proportions of the air-pumps were faulty and productive of the same results. (Bathe 1951:5)

This expert assessment was corroborated by the Confederates who served onboard the vessel after it became an ironclad.

When the Gosport (Norfolk) Navy Yard was evacuated in April 1861 in the face of an approaching Confederate force, the Federals hastily set fire to everything that could not be removed, including USS *Merrimack*. The ship was unable to leave because the engines were disconnected and parts missing in the first steps of a major machinery overhaul (Figure V.2). The frigate sank at its moorings before the fire reached the levels below the berth deck, preserving the boilers and engines.



FIGURE V.2. The burning of USS *Merrimack* and the Gosport Navy Yard, 20 April 1861
(*Battles and Leaders of the Civil War* 1991 [Vol. 1, Part 2]:693)

During the planning process in June 1861 for building an ironclad, Secretary Mallory summoned Naval Constructor John L. Porter, Lieutenant J.M. Brooke, and Engineer-in-Chief William P. Williamson to Richmond to draw up plans. According to Brooke:

...I went with Williamson to the Tredegar works, where we learned that there were no suitable engines in the South. Williamson then said he thought the engines of the *Merrimac* [sic] could be used, but that the vessel would necessarily draw as much water as the *Merrimac*, and it would not be worthwhile to build a new hull, as enough of the old hull remained to carry out the plan. Mr. Porter and I thought the draught too great, but that we could not do better. We so reported to the secretary, who concurred. (*Battles and Leaders of the Civil War* 1991 [Vol.1, Part 2]:716)

An official report to Mallory, dated 25 June 1861, soon followed:

SIR: In obedience to your order, we have carefully examined and considered the various plans and propositions for constructing a shot-proof steam-battery, and respectfully report

that in our opinion the steam-frigate *Merrimac*, which is in such condition from the effect of fire as to be useless for any other purpose without incurring a very heavy expense in her rebuilding, can be made an efficient vessel of that character, mounting 10 heavy guns, ...and from the further consideration that we cannot procure a suitable engine and boilers for any other vessel without building them... The bottom of the hull, boilers, and heavy and costly parts of the engine being but little injured, reduce the cost of construction to about one-third of the amount which would be required to construct such a vessel anew. (*Battles and Leaders* 1991 [Vol. 1, Part 2]:716-717)

Thus the burned-out hulk of *Merrimack* became the prototype Confederate ironclad, and its machinery was once again called on to move a ship too large for the amount of power generated.

During its brief but active life as CSS *Virginia*, the new ironclad encountered continuing problems with its engines. Nobody trusted them to last very long. Colonel John Taylor Wood, CSA, who served as a lieutenant on the ship during its first engagements, stated:

The motive power was the same that had always been in the ship. Both of the engines and boilers had been condemned on her return from her last cruise, and were radically defective. Of course, the fire and sinking had not improved them. We could not depend on them for more than six hours at a time. (*Battles and Leaders* 1991 [Vol. 1, Part 2]:694)

In his turn, Chief Engineer H. Ashton Ramsay reported extensively on the machinery's layout and gradually worsening state over the course of *Virginia*'s brief career. Appropriately, he provided the most complete descriptions of the boiler and engine layout and also his experiences in the engine room during battle. His testimony is quite valuable:

Her engines were radically defective [this descriptor was used quite frequently by Ramsay and other contemporary sources] in their condensing apparatus, the average vacuum [sic] maintained being about one-half that it should be after the engines had worked a short time. The links, mechanism [sic] for operating the valves and reversing the engines were also defective. The arrangement of steam chests for main and expansion valves was not well designed, involving as it did a large loss of steam. In other respects the machinery was good. The main parts [of the] shafting, propeller, cylinders, bed plates, and c., all [were] strong and of good material; the boilers, four in number, were then known as the martin type, economical in fuel but very slow [in] combustion, and sluggish in draught. The engines were of a type known as horizontal back-acting, with two cylinders, each 72" diameter and three feet stroke of piston, and as 18 pounds [per square inch] was the average pressure of steam the whole power the engine was capable of developing was only 1,000 horse... The engines were all arranged for a warship, occupying very little space vertically so the highest part of them was well under the water

line. With the boilers, however, the case was different. They stood very high, coming close under the berthdeck now to be the gundeck. (National Archives RG 45 [HA File]: Roll 13)

Ramsay then went on to describe fitting out the new ironclad, and he included interesting information regarding trials of the machinery and his interactions with the ship's commander, Franklin Buchanan. This account is significant because it presents the commander of a Confederate ironclad dealing directly with matters in the engine room:

Steam was raised and the machinery operated with the vessel tied to the wharf, a few days previous to the memorable 8th of March, when early in the morning, Captain Buchanan summoned me on deck. He questioned me closely in regard to the machinery, and as to the precautions taken to prevent the engines and boilers moving forward and the rupture of steam and other pipes in the event of a collision, possibly at full speed. After explaining in detail the methods adopted for bracing the machinery, the provision of telescopic or expansion joints to the pipes, and c., which I thought would prevent trouble to the parts referred to, he then asked if, with my knowledge of the machinery, I would be satisfied to make an attack on the fleet in Hampton Roads, without first making a trial. (National Archives RG 45 [HA File]: Roll 13)

Ramsay replied in the affirmative, and later provided stirring firsthand testimony of the scene in his department during the battle of 8 March 1862 and against USS *Monitor* the next day:

The scene in the engine and boiler rooms during the action beggared all description. Dante's Pandemonium alone approaches the weird and fiery sight here presented. The sixteen furnaces of the boilers were belching out fire and smoke, the firemen standing in front of them like so many gladiators, tugged away with devil's claw and slice bar [stoking tools], inducing by their exertions more and more intense [sic] heat and combustion; the noise of the crackling, roaring fires, escaping steam, and the loud and labored pulsations of the engines, made up a scene and sound that could be compared to the poet's picture of the lower regions. Then the bursting shell; several burst in the smoke stack just above the steam drum, the fragments falling on the iron fire room floor beneath. Two of the furnaces were arranged to heat shot, and out of these were being rolled those huge balls of fire, and passed up to the guns in iron cages, but notwithstanding the cannon's roar, bursting bombs, and suffocating heat and smoke, not a man quailed... One shot from the enemy came near inflicting a serious injury to the machinery; it was on the second day's fight, and we supposed [it was] a solid shot or bolt from the *Monitor* [sic]. It struck us on the knuckle immediately over the outboard delivery valves of the after engine on the starboard side. The effect of the shot was to crush through the outer course of iron, and bend down the lower course into the wood backing, crush a beam down to within an inch of the stern of the outboard delivery valve of the after engine, a little further and it would have been shut up. A splinter was thrown

off the beam and hurled across the engine-room with such force and velocity that it took my breath away as it passed my ear in its flight and buried itself in the iron bulkhead on the port side of the vessel. I was standing at the time with my hand on the starting valve of the after engine. (National Archives RG 45 [HA File]: Roll 13)

Virginia's chief engineer then made further note of the battle with *Monitor* but only provided small details about raising steam during a brief period aground: "...but finally, after stopping the engines for an interval, lashing down the safety valves [a very dangerous but very common practice for milking more power out of the boilers], and forcing the fires to an unusual degree, we started up again with a heavy pressure of steam..." (National Archives RG 45 [HA File]: Roll 13). Ramsay also debunked rumors of *Virginia*'s sinking condition after the battle:

...I should mention, twice before he [Lieutenant Catesby ap R. Jones] had sent for me in regard to a report that had been made to him by the carpenter of the vessel, that she was leaking forward. I told him on each occasion that it was impossible she could be making much water as the skin of the vessel was plainly visible in the crankpits, the lowest part of the ship, and that I had the means to keep her free, even if she had a ten-inch shot in her hull, as there were two large Worthington pumps and the bilge injections of the engines which could be set to work at once in case of any such emergency. (National Archives RG 45 [HA File]: Roll 13)

In the aftermath of these actions, Ramsay more than perhaps anyone else could see that *Virginia*'s old engines had been pushed nearly to the breaking point. Little work was done on them despite his concerns. He later made a detailed report on this issue to *Virginia*'s second and final commander, Commodore Josiah Tattnall, on 5 April 1862:

From my past and present experience with the engines of this vessel, I am of the opinion that they cannot be relied upon. During a cruise of two years whilst I was attached to this ship in the United States service they were continually breaking down, at times when least expected, and the ship had to be sailed under canvas during the greater part of the cruise. When she returned, the chief engineer reported that experiments to improve their working and reliability had failed, and, as the defects were radical, embracing the entire engines, recommended that they should be removed from the vessel, and such was the intention of the U.S. Government before she fell into our hands. The engines gave out yesterday, as I had occasion to report to you, after running only a few hours, and as I can not insure their working any length of time consecutively I deem it my duty to make this report. At the time I was ordered to the vessel I was informed that it was not the intention to take the ship where a delay, occasioned by a derangement of the machinery, would

endanger her safety, and that she would always be accessible to the navy yard for repairs; this is the reason why I have deferred making this report until this time; and I also was under the impression that the Navy Department was aware of the defective nature of the machinery, and [that] her movements would be directed with a reference to this. Each time that we have gone down [into Hampton Roads] I have had to make repairs which could not have been done aboard ship very well, or, if done at all, would have required a great deal of time. (*Official Records of the Union and Confederate Navies in the War of the Rebellion* 1987 [Ser. 1, Vol. 7]:758-759)

He reported further on the unsuitable nature of the steam line connections and continuing repair work over the course of the next few days:

The engines of this ship are not disconnected, and one cannot be worked alone. As long as the vacuum of the forward engine holds good, the engines might be run by working the after-engine high pressure; but the vacuum of either engine is at all times precarious, and if the vacuum of the forward engine should fail, the engines would stop. Using one engine high pressure would also require a great deal of steam, which the boilers cannot generate for any length of time. The air-pump valves are now being overhauled... (*Official Records, Navies* 1987 [Ser. 1, Vol. 7]:759)

The problems with permanently connected engines and underpowered boilers were a problem that ultimately plagued several other Confederate ironclads.

Another valuable testimony regarding the functioning of *Virginia's* engines in active service comes from Third Assistant Engineer E.A. Jack. He recorded several interesting details of serving in the engine and fire rooms during his ship's battles. He first described his impressions of the machinery, which corroborate Ramsay's:

Her motor power was two horizontal condensing engines, which were supplied with steam from four Marlin [Martin] boilers containing three furnaces each. The engines operated by link-gear which was shifted by the arc and pinion movement and were quite difficult to manage, and required at least two men at each reversing gear. For one of the furnaces, a frame of wrought iron was made upon which shot for smooth bore guns could be placed and heated and tool and trivets were supplied to handle and carry them to the guns. There were two auxiliary steam pumps of the Worthington type, with about six-inch cylinders. These pumps could be used either to supply the boilers with water or to pump water from the bilge. (Flanders and Westfall 1998:10)

Jack also wrote regarding the fight of 8 March against the wooden Union blockading vessels in Hampton Roads:

The preparation for the fight now began on our ship and all hands were called to quarters, and I sought my station down in the fire-room twenty feet under water mark... The suspense was awful, but it was relieved occasionally, by some information through the ash chute that my comrade White [3rd Assistant Engineer E.V. White] would communicate. (Flanders and Westfall 1998:15)

In this manner, Jack and the other men in the fire room were apprised of the situation outside and learned of *Virginia's* incredible victory over the blockading fleet that day.

Virginia's monumental battle with USS *Monitor* on 9 March, shown in Figure V.3, was recorded in some detail by Jack, but he had relatively little to say about operations in the machinery spaces. Like Ramsay, he briefly related the shell hit near the waterline:

One shot struck directly over the outboard delivery, and because that was a weak spot broke the backing of the shield and sent a splinter into the engine room with about enough force to carry it halfway across the ship. (Flanders and Westfall 1998:16)

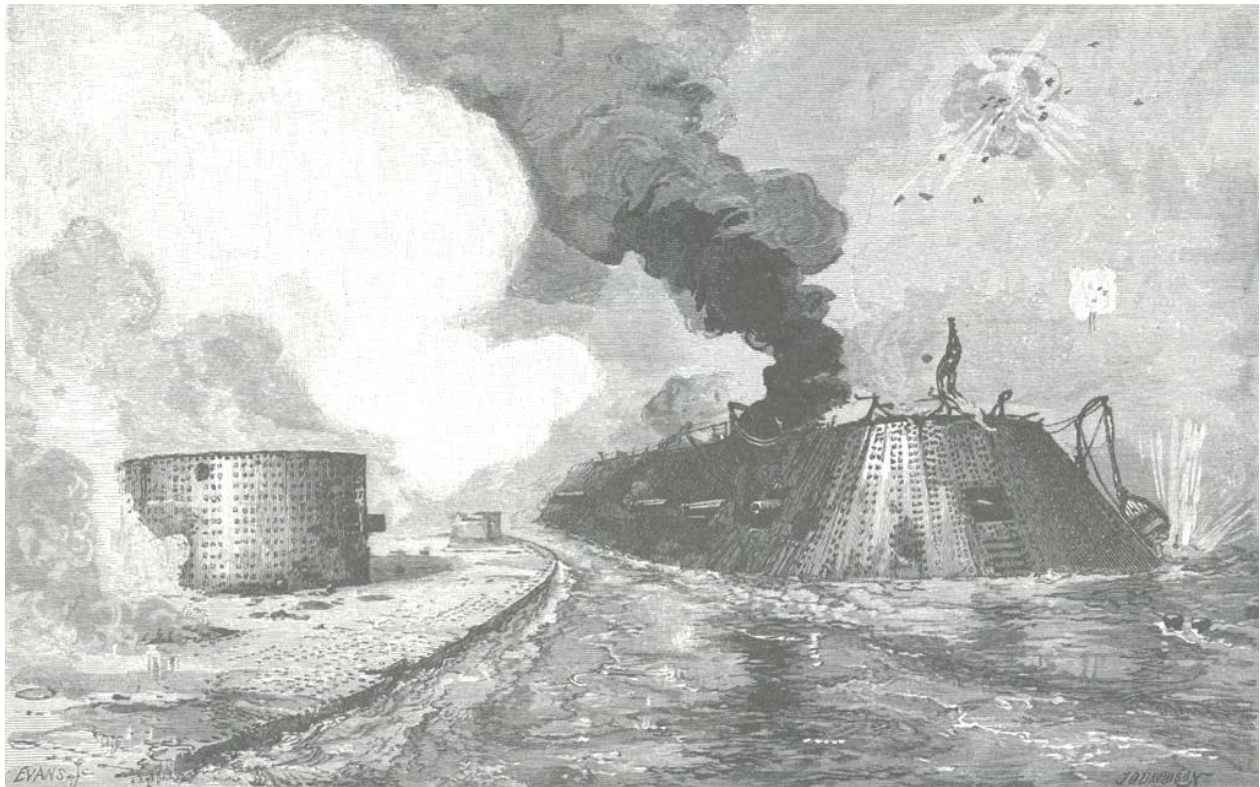

FIGURE V.3. The world's two most famous ironclads, USS *Monitor* and CSS *Virginia*, slug it out at short range on 9 March 1862. (*Battles and Leaders* 1991 [Vol. 1, Part 2]:708)

Jack, also like Ramsay, made note of the rumors after the battle that *Virginia* had been forced to retire due to bad leakage from ramming *Cumberland* the previous day and attempting to do the same to *Monitor* in turn:

As I was in the fire-room within sight of the steam bilge pumps at all times, in fact sitting by them often, I know that they were not required to do any extraordinary duty and that no alarm about the sinking or leaky condition of the ship was felt in that section...
(Flanders and Westfall 1998:17)

This testimony offers another rare glimpse into actual battle conditions in the engine room and stokeholds of a Confederate ironclad warship. Unfortunately, there appear to be no similar accounts of *Virginia*'s operations after the battle with *Monitor*.

Regarding CSS *Baltic*

Little information exists concerning one of the Confederacy's first ironclads and the only armored vessel to serve on Mobile Bay for over a year: CSS *Baltic*. Fortunately, some details do exist regarding the machinery, mostly due to a Union survey of the captured vessel at war's end. Not many records concerning Alabama's first ironclad have been found and Confederate documents relating to the vessel are almost nonexistent (Holcombe 1993:25).

Baltic was originally a sidewheel towboat serving as a cotton lighter on Mobile Bay. It was bought for a sum of \$40,000 cash in December 1861 by a commission specially charged with selecting a vessel for conversion to an ironclad. Conversion began quickly on 21 December 1861 and was finished the next May (Wilson 1938:2-3). It appears that as a casemate ironclad ram mounting four guns *Baltic* was extremely slow and began to suffer from rotteness. The boilers were also described as being out of repair. The few Confederate accounts clearly reveal that service on the ironclad was uncomfortable at best and no one had any real faith in its abilities.

On 20 March 1864, *Baltic*'s commander, Lieutenant Charles Simms, wrote:

Porter, the naval constructor, has made a very unfavorable report of the condition of the ship and recommended that the iron be taken from her... the *Baltic* is as rotten as punk, and is about as fit to go into action as a mud scow. (*Official Records, Navies* 1987 [Ser. 1, Vol. 21]:886).

Towards the end of the war, Flag Officer Randolph Tucker wrote a report concerning the unsafe condition of the boilers: “The boilers of the steam ram *Baltic* were pronounced by the engineers as unsafe, and were being patched and strengthened...” (*Official Records, Navies* 1987 [Ser. 1, Vol. 18]:660). This was after the deteriorating vessel’s armor had been removed (both for safety purposes and supplying another ironclad, CSS *Nashville*, with much-needed iron plate). Not long afterwards *Baltic* was decommissioned. At war’s end, it was sent up the Tombigbee River with several other Confederate vessels and subsequently surrendered to Federal authorities. A Union survey of the ship in June 1865 reported, among other things:

...The *Baltic* is built like all other river steamers, but was strengthened when she was constructed into a ram. Her hull is in good condition below the load line, but above the load line her hull and upper works are rather rotten in some places. Her main deck is in a very bad condition and rather rotten. Her cylinder timbers are affected with the dry rot in some places, and not very well secured. ...

These engines are in good condition and repair, with the exception of the timberwork... This ship is not safe to run in consequence of the bad condition of the boilers. (*Official Records, Navies* 1987 [Ser. 1, Vol. 22]:226-227)

According the full survey report, repairs were planned initially but nothing came of it and the worn-out vessel was broken up sometime after December 1865 (Naval Historical Center 2012).

Regarding CSS *Louisiana*

The giant ironclad *Louisiana* was one of the first vessels constructed as part of Secretary Mallory’s ironclad policy. It and the other early ironclads were large and strong with the intention of combined harbor and open water service. In reality, most had serious weaknesses. *Louisiana*’s were perhaps the greatest among these.

What became one of the South's largest ironclads was begun on 15 October 1861 at Jefferson City, Louisiana. The builder was E.C. Murray, an early proponent of ironclads and an experienced constructor of riverboats. *Louisiana* was designed as a flat-bottomed craft with straight sides supporting a massive 45 degree-angled casemate (Holcombe 1993:47). The vessel's machinery arrangement of two center-mounted paddlewheels and two propellers was not just unusual, but extremely troublesome. *Louisiana*'s lack of motive power caused by problems with the machinery layout and installation plagued it throughout its short career, and contributed to its loss.

Most contemporary accounts regarding *Louisiana* come from the 1863 *Report of Evidence Taken before a Joint Special Committee of Both Houses of the Confederate Congress, To Investigate the Affairs of the Navy Department* which investigated the spectacular loss of New Orleans along with two of the South's largest ironclads (CSS *Mississippi* in addition to *Louisiana*). These testimonies describe the efforts to install *Louisiana*'s machinery, most of which came from the river steamer *Ingomar* (Still 1985:45). The ironclad was still incomplete due to delays in construction when ordered 60 miles downriver to Fort St. Philip to prepare for defense against Flag Officer Farragut's approaching fleet. Commander John K. Mitchell, in charge of the Confederate naval defenses below New Orleans, testified:

To have prepared her fully for a fight, it would have taken at least six weeks, if not two months longer. In work of that kind there are many causes of delay. For instance, we were a long time waiting for the propellers. The engineers were promising every day that they would be ready, but they failed to come up to their promise, though I am satisfied it was made in good faith. The work was much more arduous and difficult than they apprehended. (Confederate States of America [CSA] 1863:29)

Louisiana's motive power was only partially assembled when the deployment order came. The giant ironclad was incapable of stemming the Mississippi current with just paddlewheels.

According to the ship's third lieutenant, William C. Whittle:

She had two propellers aft, which we never had an opportunity of testing. ... The vessel left New Orleans on the 20th of April, I think. The work on the propellers was incomplete, the machinists and mechanics being still on board... The center wheels were started, but were entirely inefficient... (*Battles and Leaders* 1991 [Vol. 2, Part 1]:48)

Louisiana had to be towed down to a mooring adjacent to Fort St. Philip (Figure V.4).

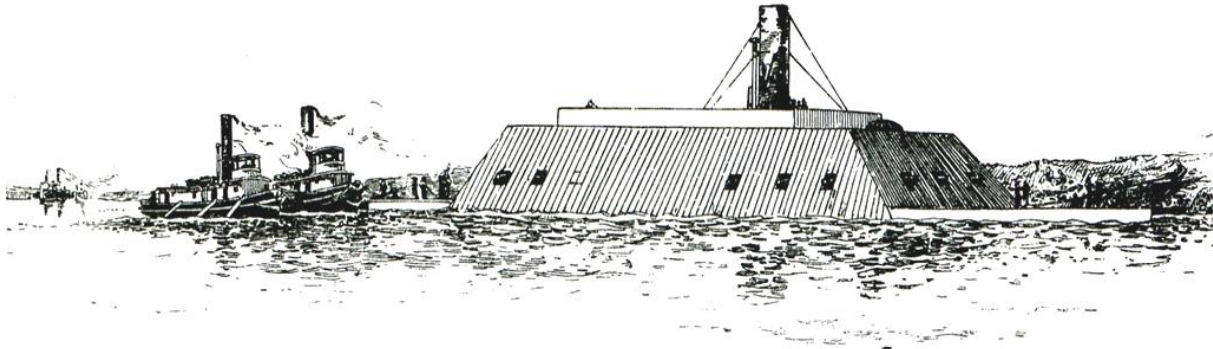

FIGURE V.4. CSS *Louisiana* being towed downstream from New Orleans to Fort St. Philip. Several tugs were required to assist the unwieldy 2,700-ton ironclad. (*Battles and Leaders* 1991 [Vol. 2, Part 1]:48)

Workers continued to feverishly assemble *Louisiana*'s propeller engines and shafts, but the Union attack came before their completion. On 24 April 1862, Farragut's fleet stormed past the forts and proceeded upriver to take New Orleans. Most of the Confederate fleet was destroyed, but *Louisiana* had resisted the heaviest Union guns without damage and remained tied to the bank. By 28 April, the work was finally done but *Louisiana* would not move even with full steam pressure and both wheels and propellers operating (Holcombe 1993:49). The huge ironclad was subsequently destroyed to prevent capture when the nearby forts surrendered.

Chief Engineer Wilson Youngblood, reporting to Commander Mitchell while a prisoner in August 1862, had a final word on the failure of one of the Confederacy's strongest ironclads:

SIR: I respectfully report the machinery of C.S.S. *Louisiana* all in good working order on the morning of April 28, 1862, just before it became necessary to destroy the vessel.

But I do not think it would have been able to handle the vessel, the wheels being put in the middle of the vessel, one right abaft the other, so that the after wheel could do no good whatever.

And again, when the wheels were working, they would force the water out under the stern so that it would form an eddy around the rudder so that she would not steer, and if

we tried [to] steer her with the propellers, she could not stem the current. Consequently she was unmanageable in the Mississippi River. (*Official Records, Navies* 1987 [Ser. 1, Vol. 18]:318)

Regarding CSS *Arkansas*

Only one other Confederate ironclad approaches CSS *Virginia* in level of fame. CSS *Arkansas*, one of the first-generation ironclad designs of Mallory's initial 1861 program, was a product of Memphis, Tennessee. It was intended to defend the Confederacy on the upper Mississippi River. During its brief service life, *Arkansas* garnered more glory than any other Southern ironclad. Fortunately, abundant information regarding the exploits of this remarkable vessel has been preserved in the accounts of its equally remarkable master and officers.

Arkansas was begun at Memphis, but after the fall of New Orleans and the approach of a Federal gunboat fleet, the senior naval officer quickly ordered the removal of *Arkansas*'s incomplete hull to a safe location in the swamp. Simultaneously, he ordered the destruction of a sister ship, to have been named *Tennessee*, still on the stocks (Still 1985:62). By this turn of events, *Arkansas* was preserved and eventually moved to Yazoo City, Mississippi, far up the Yazoo River. There, construction lagged for want of materials, skilled workers, and pusillanimous leadership. All that changed when Lieutenant Isaac Newton Brown was ordered to take over command of the vessel. He arrived on 29 May 1862 and promptly got things moving (Still 1985:64).

The ironclad's engines, built in Memphis, were onboard but not connected when Brown took command. In fact, the whole ship was a cluttered mess. Brown wrote:

Her condition was not encouraging. The vessel was a mere hull, without armor; the engines were apart; guns without carriages were lying about the deck; a portion of the railroad iron intended as armor was at the bottom of the river, and the other and far greater part was to be sought for in the interior of the country. (*Battles and Leaders* 1991 [Vol. 3, Part 2]:572)

With a herculean effort of will and organizational skill, Brown succeeded in speedily finishing *Arkansas*. He recognized the vessel's deficiencies, especially the engines which were new and purpose-built. In the end, these proved to be the ship's greatest weakness:

Our engines' twin screws, one under each quarter, worked up to eight miles an hour in still water, which promised about half that speed when turned against the current of the main river. We had at first some trust in these, not having discovered the way they soon showed of stopping on the center at wrong times and places; and as they never both stopped of themselves at the same time, the effect was, when one did so, to turn the vessel round, despite the rudder. Once, in the presence of the enemy, we made a circle, while trying to make the automatic stopper keep time with its sister-screw. (*Battles and Leaders* 1991 [Vol. 3, Part 2]:572)

E.A. Jack, assigned to the engineering staff of *Arkansas* in the aftermath of *Virginia's* destruction, provided a description of the equally discouraging conditions in the engine room:

The quarters were cramped, hot, and badly ventilated. In the engine room, which was petitioned from the ward-room access only by a rough board fencing about four or five feet high, the thermometer indicated over 100. Such a temperature when the engines were at rest and the fires low gave promise of trying and exhausting duty when underway or in action... (Flanders and Westfall 1998:23)

Jack was soon to find that his first impressions were only too accurate. Commander Brown was soon ready to take the fight to the enemy after hurriedly finishing the ironclad and scrounging together a crew. He had heard of the Union fleet massing near Vicksburg and on the morning of 14 July 1862, *Arkansas* departed for battle.

Before the new ironclad had gone very far, the hasty construction of the ship's steam plant became apparent to all. Brown continued his account:

Fifteen miles below [Satartia, Mississippi], at the mouth of the Sunflower River, we found that the steam from our imperfect engines and boilers had penetrated our forward magazine and wet our powder so to render it unfit for use. (*Battles and Leaders* 1991 [Vol. 3, Part 2]:573)

The crew was able to dry the powder by laying it in the sun but valuable time had been lost.

Nothing happened despite Lieutenant Brown's worries until dawn the next day, 15 July, as *Arkansas* approach the junction of the Yazoo River with the Mississippi. The ironclad encountered three enemy vessels there: the ironclad USS *Carondelet*, the wooden gunboat *Tyler*, and the ram *Queen of the West*. The Confederates gave chase and exchanged fire in a sharp battle as the Union vessels retreated towards the Mississippi. While *Arkansas* incurred some damage, the Federals received the worst of it. *Carondelet* was disabled and run aground and *Tyler* only managed to escape with severe damage. Brown continued:

On gaining the Mississippi, we saw no vessels but the two we had driven before us. While following these in the direction of Vicksburg I had the opportunity of inspecting engine and fire rooms, where I found engineers and firemen had been suffering under a temperature of 120° to 130°. The executive officer, while attending to every other duty during the recent firing, had organized a relief party from the men at the guns, who went down into the fire-room every fifteen minutes, the others coming up or being, in many instances, hauled up, exhausted in that time; in this way, by great care, steam was kept to service gauge, but in the conflict below the fire department broke down. The connection between furnaces and smoke-stack (technically called the breechings) were in this second conflict shot away, destroying the draught and letting flames come out into the shield, raising the temperature there to 120°, while it had already risen to 130° in the fire-room. (*Battles and Leaders* 1991 [Vol. 3, Part 2]:575)

The "second conflict" that Brown referred to was the arrival of *Arkansas* at Vicksburg and the engagement between that vessel and no less than the combined fleets of Union admirals Farragut and Porter. In the meantime, Third Assistant Engineer Jack corroborated Brown's account of conditions in the engine and boiler rooms during the battle:

...the heat in the engine room was almost unbearable and in the fire-room the glowing red furnace doors shot out such heat that the men had to be frequently relieved and would gladly take a turn to rest on the quarterdeck where shot were flying around in preference to staying below where they were better protected. I do not remember the temperatures then, but do not think it extravagant to say that it was above 130. (Flanders and Westfall 1998:23)

CSS *Arkansas*'s moment of glory came when Lieutenant Brown led the already-battered ironclad through the combined Union fleet off Vicksburg, singlehandedly engaging over 50

enemy vessels (Figure V.5). The Confederates inflicted great damage and confusion but barely made it to safety under the guns of Vicksburg itself:

It has been asked why the *Arkansas* was not used as a ram. The want of speed and of confidence in the engines answers the question. We went into action in Old River with 120 pounds of steam, and though every effort was made to keep it up, we came out with but 20 pounds, hardly enough to turn the engines. (*Battles and Leaders* 1991 [Vol. 3, Part 2]:575)

Second Lieutenant George W. Gift further described the scene onboard during the great battle:

...But still the ship was not disabled; seven guns [out of 10] were still hammering away, and the engines were intact. But steam was down to a terribly low ebb. The party who had fitted up the boilers had neglected to line the fire front with non-conducting material; the consequence was that when a heavy fire of coal was put in the whole mass of iron about the boilers became red-hot and nearly roasted the firemen, who had also got a tub of ice-water, of which they drank freely. (Gosnell 1949:121)

The battered *Arkansas* finally reached the wharves of Vicksburg, having scored one of the most dramatic victories of any Southern ironclad.

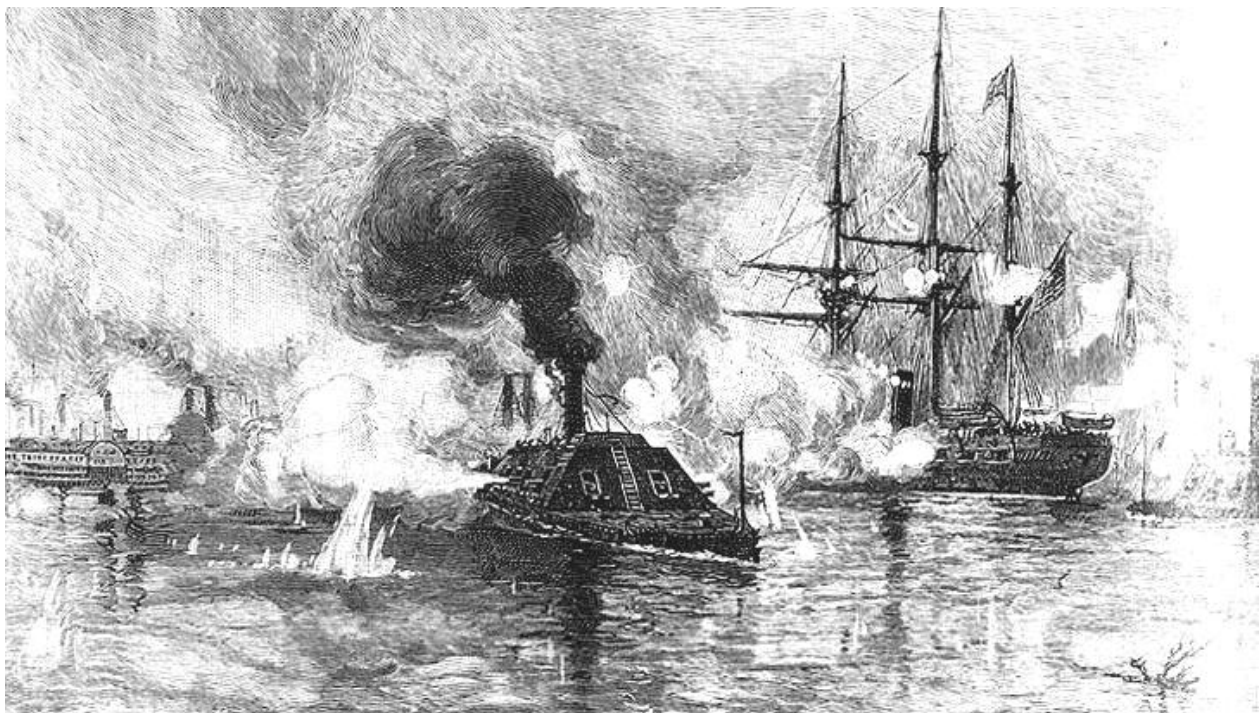

FIGURE V.5. CSS *Arkansas* runs the gauntlet through the Union fleets above Vicksburg on 15 July 1862. The ship's sides were actually vertical rather than angled as shown here. *Arkansas* was the only Confederate ironclad so designed. (*Battles and Leaders* 1991 [Vol. 3, Part 2]:556)

Arkansas sat at Vicksburg for a week effecting repairs but constantly under the bombardment of the Union fleet. Farragut's forces steamed to a point below the batteries at Vicksburg during the night of 15 July and hammered at the Confederate ironclad as they passed. Serious damage was inflicted in the engine room. Gift wrote:

An eleven-inch shot pierced our sides a few inches above the water-line, and passed through the engine-room, killing two men outright (cutting them both in two) and wounding six or eight others. The medicines of the ship were dashed into the engine-room, and the debris from the bulkheads and splinters from the side enveloped the machinery. (Gosnell 1949:125)

This shot may have partly accounted for the increasingly temperamental state of *Arkansas*'s power plant on its final voyage. It apparently did significant damage to one of the engines. In the meantime, further conflicts with the Union ironclad *Essex* continued to hamper repair efforts. Finally the Union fleets retired to the south after a week of ineffectual attempts to destroy *Arkansas*, and Vicksburg was temporarily left in peace.

Arkansas's final voyage came in August when it was ordered south to aid in an attempt to retake Baton Rouge. On 3 August Brown was away on sick leave, leaving the ship in charge of the executive officer, First Lieutenant Henry K. Stevens (Still 1985:75). Consequently, *Arkansas* left Vicksburg for battle without its captain or chief engineer. Many problems soon developed, as Gift explained:

...we left Vicksburg thirty hours before General Breckinridge [the Confederate commander at Baton Rouge] had arranged to make his attacks. The short time allowed to arrive at the rendezvous made it imperative that the vessel should be driven up to her best speed. This resulted in the frequent disarrangements of the machinery and consequent stoppages to key up and make repairs. Every delay required more speed thereafter in order to meet our appointment. Another matter operated against us. We had been compelled to leave behind, in the hospital, our chief engineer, George W. City, who was worn out and broken down by excessive watching and anxiety. His care and nursing had kept the machinery in order up to the time of leaving. We soon began to feel his loss. The engineer in charge, a volunteer from the army, had recently joined us, and though a young man of pluck and gallantry, and possessed of great will and determination to make the engines work, yet he was unequal to the task. He had never had anything to do with a

screw vessel or short-stroke engines, and, being zealous for the good repute of his department, drove the machinery beyond its powers of endurance. (Gosnell 1949:132)

Engineer Jack was in the engine room and provided firsthand testimony of these problems. His detailed account suggests that it was unnecessary adjustments made to the engines, not necessarily faulty manufacture or hard use, which ultimately ruined them:

Indeed the engines were good as they were, and as capable of carrying the vessel through an attack on the enemy as they had ever been. This new Chief...wanted to make alterations in the lap of the steam valve... I had just examined the set of it and was closing the steam chest when I became aware of the presence of a stranger who was looking on. "I want to look at that valve," he said. I regretted that he had not come aboard sooner as it was too much trouble to open the chest again and I was very busy. But he replied, "I have come on board by Capt. Brown's order to take charge of these engines". I did not know whether I was talking with a lunatic or not, but Mr. Stevens, coming up at this time, confirmed the newcomer's rank and I proceeded to obey orders. I took off the cover and disconnected the valve and took it from the chest. Then it was that he sagely remarked, "I do not wonder that this thing does not work: it is an inch too long on both ends. I will make it shorter". I cannot express my surprise when he said this, for I knew that if he did it, the valve would be ruined and the vessel delayed until a new one could be gotten. How long that would have been I cannot say, but I doubt if one could be gotten short of Richmond. The old valve might have been repaired, but that too would have taken some time. I could not help telling this new and experienced officer that he would ruin the valve if he altered it as he contemplated, but he smiled knowingly, and, as if it was presumption in a youngster to differ with him, turned away. I protested then to Lieut. Stevens, but he said, "This officer is more experienced than you and I suspect he knows what he is talking about". I then asked that [sic] he would speak to Mr. City. Mr. City tells me that he did, and that he told Mr. Stevens that I was right and the man was a fool. But he was kept although the alterations were not made in the valve. (Flanders and Westfall 1998:25)

It would seem that Jack had helped prevent a serious problem in this regard, but ultimately the engines were tampered with during what should have been routine maintenance. Jack's continuing detailed account of these blunders makes abundantly clear that he believed they were the cause of *Arkansas*'s downfall:

Lieuts. Stevens and Gift have both written that it was due to a breakdown of the engines. The loss of the vessel was indisputably due to that, but what led to that breakdown has never been written. It might reasonably be asked why the engines that had brought this ship through the fleet off the Yazoo River, fighting every inch of the way, and which had been so successfully handled when the two attacks were made upon her at Vicksburg, had

become so inefficient at this critical time. A practical man would suspect that they had been badly managed, indeed tampered with, and would not be very far from the truth. Our trip was one of accidents and delay from the beginning to the end. The first stop because of the machinery was unavoidable. It was caused by a loose key in the rock-shaft arm. An examination disclosed that the key-way was very much worn, and it was thought advisable to true up the way and fit a new key. The link was disconnected, the repairs made, and the machinery coupled up again. This latter duty was carefully performed under the supervision of the experienced chief engineer Fauntleroy, and I did the work on the rock-shaft, and when that was finished, took a rest which we deserved. The others our relief connected up. In fact I am quite certain that they disconnected the link. At any rate, no marks were made by which a proper length of the eccentric rods might be preserved, and in putting them up again one was left longer than normal and when the engine was moved it drove the steam valve against the end of the chest and broke the pin in the rocker-arm which had just been secured. Our work held, but the pin gave way. A new pin was forged, and Fauntleroy fitted that and gave it to an assistant named Gettis to secure, but he took it and heated it red hot to make it easier to rivet in place, and tried to drive it into place hot. Of course it would not fit as it had expanded from the red heat it had, but he up [sic] with sledge and tried to drive it home. In this he failed, but he succeeded in spoiling the pin which had to be fitted again. (Flanders and Westfall 1998:25-26)

Jack and the others became more exasperated as the voyage continued. The engines grew more temperamental as *Arkansas* hurried south. Lieutenant Stevens began to be worried about taking his ship into action and whether he would even be able to make it to Baton Rouge. Gift continued his account of *Arkansas*'s last voyage:

...At or near the mouth of Red River, the engines had grown so contrary and required to be hammered so much that Stevens deemed it was his duty to call a council of war to determine whether it was proper to proceed or return. The engineer was summoned and gave it as his opinion that the machinery would hold out, and upon that statement we determined to go ahead. A few miles below Port Hudson he demanded a stoppage to key up and make all things secure before going into action. (Gosnell 1949:132)

Arkansas continued with good speed toward Baton Rouge after this last repair but by the time the ironclad reached the city, the land battle was all but over.

E.A. Jack had a final say about the culpability of the civilian engineering specialists and the frantic work below decks before the final battle:

When I went on watch I was his [civilian assistant Gettis] relief, and going around with him to examine into the condition of the department, I saw a machine I was not familiar with. I knew it to be a Giffard's [Gifford's] injector, but [did] not know how to operate it.

So I asked him to show me how it started. Much to my surprise he declined to do so, and told me to learn to operate it as he had. I had the authority to compel him to show me, but my professional pride was touched, so throwing aside our official relations, I determined to show him that I could do as he had so uncivilly advised. And when he had gone, after a few trials, I succeeded in manipulating the machine successfully. Well, after the new pin [referred to previously] was fastened in place and the eccentrics adjusted, another start down the river was made. But next the coal supply was found to be insufficient and another landing was made at a plantation to replenish the bunkers. Whether this was an oversight, or there were no coals in Vicksburg I don't remember. While the coaling was going on, the starboard cylinder was opened and the packing in the piston was set out. This engine worked the port wheel, which you will learn hereafter became inoperative and caused the loss of the vessel. This tinkering with the engine was altogether unnecessary. The civilian engineer was, in my opinion, culpable in permitting it, and guilty as well of negligence in not seeing that the packing was properly adjusted, instead of entrusting such an important matter to an assistant who was not familiar with it... Day came before we had finished coaling, and when it was quite light we cast off our lines and started down river once more. (Flanders and Westfall 1998:26)

At a clear area above Baton Rouge, the crew learned that the USS *Essex* and other Union vessels were still present. The Confederates accordingly decided to attack them. Gift wrote:

Stevens assented to the proposal [to ram *Essex*] and had just remarked that we had better go to our stations, for we were in a hundred yards of the turn [in the river], when the starboard engine stopped suddenly, and, before the man at the wheel could meet her with the helm, the ship ran hard and fast aground, jamming herself on to some old cypress stumps that were submerged. ... On investigation it was found that the engine was so badly out of order that several hours must be consumed before we could again expect to move. There lay the enemy in plain view, and we as helpless as a shear-hulk. (Gosnell 1949:134)

Commander Stevens saved a copy of the engineering report submitted to him at this time.

Its main point was: "From my examination of all the defects in the...engines, it will be impossible for me to put them in fit condition to render efficient aid to propel the ship into action..." (Still 1985:76). *Arkansas* now appeared to be in dire straits. It is best to let George Gift end the story here in his own words:

...Stevens was not the man to give up. A quantity of railroad iron, which had been laid on deck loose, was thrown overboard, and in a few hours we were afloat. The engineers had pulled the engine to pieces and with files and chisels were as busy as bees, though they had been up constantly then for the greater parts of the two preceding nights. At dark [on 5 August] it was reported to the commanding officer that the vessel could be moved. In

the meantime some coal had been secured (our supply was getting short), and it was determined to run up stream a few hundred yards and take it in during the night, and be ready for hot work in the morning. Therefore we started to move, but had not gone a hundred yards before the same engine broke down again; the crank pin (called a 'wrist' by Western engineers) of the rock-shaft broke in two. Fortunately one of the engineers was a blacksmith, so the forge was set up and another pin forged. But this with our improvised facilities used up the whole night. Meantime the enemy became aware of our crippled condition, and at daylight moved up to the attack. The Essex led, and came up very slowly, at a rate not to exceed two miles an hour. She had opened on us before the last touch had been given to the pin, but it was finished and the parts thrown together. ... The pleasant sensation of again being afloat and in possession of the power of locomotion was hardly experienced before our last and final disaster came. The port engine this time gave way, broke down and would not move. The engineer was now in despair; he could do nothing, and so reported. The Essex was coming up astern and firing upon us. We had run ashore and were a hopeless, immovable mass. (Gosnell 1949:134-135)

Also describing the situation in those final moments, Jack's account adds further harrowing detail:

Immediately after our guns opened fire [on *Essex*], one of our engines stopped. My impression then was that the shot that had struck so close astern of us had struck our propellor [sic], for its fall, the discharge of our guns, and the stoppage of our engine came very close together. I rushed down from the casemate and passed below through the hatch in the overhang aft, and just as I had gotten below, another of our after guns was fired. I found them trying to move the starboard engine, which was somehow jammed and the engine room full of steam that was escaping from the overstrained joints. I felt sure then that our shaft had been bent by the shot which had struck astern of us, for I did not know that the packing had been set out in that engine as I was ashore when it was done, attending to the coaling. (I learned this afterwards from Asst. Engineer Fauntleroy who saw it done.) If I had known it, there would have been no doubt in my mind as to the cause of the engine stoppage. All efforts to start the disabled engine failed. The port engine was kept at work and in a short time the ship was run ashore on the west side of the river, and abandoned and fired. ... The excitement in the engine room because of the disabled engine and the pell-mell way in which both officers and men abandoned the ship... completely unnerved me for a while. (Flanders and Westfall 1998:26-27)

In the face of enemy fire and risking capture by Union troops moving up the bank, Commander Stevens made the decision to destroy his vessel. Accordingly, the crew abandoned ship into the swamp and the South's most gallant ironclad burned and blew up. In the fitting words of H.

Allen Gosnell 1949:135, "Her career lasted only twenty-three days, but what a career! It included

so much action that there probably never was another vessel that averaged anything like as much fighting per day as did the *Arkansas*".

Regarding CSS *Richmond*

The prototype for the largest single class of ironclads completed by the Confederacy was the Norfolk-built *Richmond*. Construction on this vessel was based on Chief Naval Constructor John L. Porter's 1846 ironclad design and had begun at the Gosport Navy Yard prior to its abandonment by Southern forces in May 1862 (Still 1985:94). Consequently, the unfinished single-screw ironclad was towed to Richmond and completed there.

While *Richmond* incorporated many design improvements over *Virginia*, it still suffered from a deep draft and a weak single-cylinder engine taken from a former lightship (Coski 2005:80). Many criticized both the length of time required to finish the vessel and its secondhand machinery. Lieutenant John Taylor Wood, CSA, wrote:

I doubt very much if she goes below the barrier [Confederate obstructions placed across the James River near Drewry's Bluff], for with her weak engine (80 horse) she would be mobbed and forced out of the channel. She will not steam more than 5 knots, if that. (*Official Records, Navies* 1987 [Ser. 2, Vol. 2]:256)

In his turn, George Weber, a sailor on the Confederate Navy school ship *Patrick Henry*, echoed similar sentiments: "...the worst thing...is that she carries bad engines" (Coski 2005:80). Nevertheless, *Richmond* became by far the strongest naval defender of the Confederate capital upon completion in November 1862. The other ironclads of the nascent James River Squadron would not be completed for another 16 months (Coski 2005:91).

Richmond was kept busy as flagship until the completion of the other James River ironclads but only saw one actual battle toward the end of its career. Worry over the "defective" engine persisted, especially when considerations were afoot to send the ship on the offensive below the river obstructions. Army engineer Alfred Rives noted: "...it would certainly seem of

doubtful policy to send below an ironclad vessel with [an] inferior single-acting engine...” (*Official Records, Navies* 1987 [Ser. 1, Vol. 8]:841-842). Perhaps there was upper-level realization of this “doubtful policy,” for *Richmond* was never called on for such a risky venture while operating by itself.

A bit of information concerning typical conditions encountered in the machinery spaces of *Richmond* has come down in the accounts of Chief Engineer Henry X. Wright. His reports reveal that the usual size of the engine and fire room crew was 10 men, and that weekly inspections were held by him, the chief engineer of the squadron (Wright 1863: Folders 13,14). In a report to Flag Officer John K. Mitchell (the same Mitchell who had earlier served at New Orleans) dated 21 October 1864, Wright stated:

In regard to the engineers, I would state that she should have another assistant... Besides, the engine is a very unhandy, hard-working one, and the engine room very hot and uncomfortable. I would state that the temperature has been as high as 150° Fahrenheit during last summer, and is considered to be one of the hottest engine rooms in the Confederacy. (*Official Records, Navies* 1987 [Ser. 1, Vol. 10]:792)

The “unhandy” single-cylinder engine appears to have given remarkably little trouble despite the difficulty of working in such conditions and the constant duty experienced by *Richmond* during its career. It apparently functioned well even during the Battle of Trent’s Reach on 24 January 1865, which was the only significant engagement fought by the James River ironclads (Figure V.6). Not long afterwards on 3 April 1865 they were all destroyed to prevent capture after the abandonment of the Confederate capital.

Regarding CSS *Chicora* and *Palmetto State*

The first two ironclads built for the defense of strategically-important Charleston Harbor were both of the same design as *Richmond*. These vessels, *Chicora* and *Palmetto State*, operated together for their entire career and were considered among the best-maintained ironclads in the

Confederacy (Still 1985:115). Unfortunately, like so many other Southern ironclads they lacked satisfactory steam machinery.

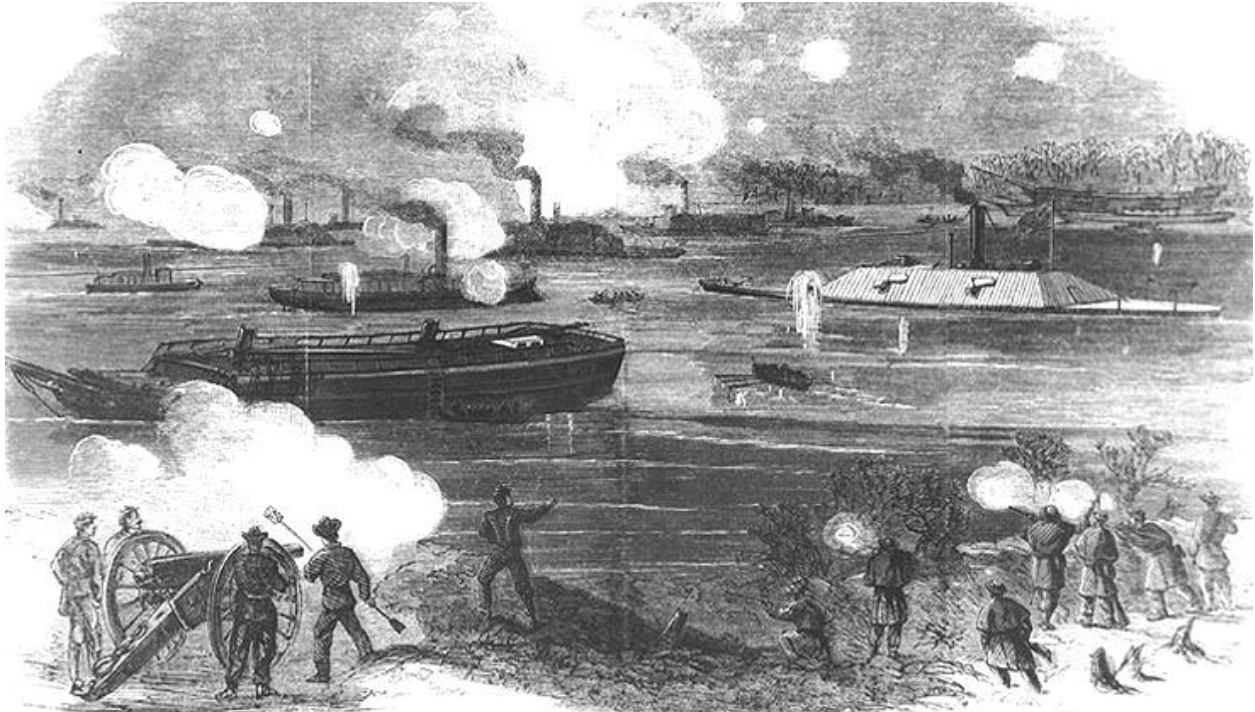

FIGURE V.6. The Battle of Trent's Reach, 23 January 1865. The ironclad at right, with two pilot houses, is CSS *Fredericksburg*—CSS *Richmond* is one of the more obscure vessels in the background. (Online Library of Selected Images, Naval Historical Center, Department of the Navy, Washington, DC, 2012)

Both vessels were laid down in March 1862, but *Chicora* was completed in August with *Palmetto State* following in October (Holcombe 1978:17). The two ships were identical in most respects but could be distinguished by *Palmetto State*'s octagonal casemate (Holcombe 1993:67). Both ironclads were painted a pale blue-gray like that of the blockade runners and both had engines taken from tugboats.

The engines of *Chicora* and *Palmetto State* seem to have given fairly good service despite being underpowered for the size of the ships. James H. Tomb, Third Assistant Engineer onboard *Chicora*, recorded his first impressions:

The engine was single acting and was taken from a tug. While the engine was lacking in power, she was a good ship, after so many tinder boxes and cook shops we had had. She

was thought to be able to make eight knots without forced draft, but when completed, could not under the most favorable circumstances make over seven. (Campbell 2005:54-55).

Similar sentiments were expressed by Lieutenant William H. Parker of *Palmetto State*: “Her engines always worked well, and under favorable circumstances she would go seven knots per hour, though her average speed was about six” (Parker 1883:288). He continued further regarding the operations and cleanliness of the two ironclads:

...they were fine specimens of men-of-war and would have done credit to any navy. They were well officered and manned. ... They were the cleanest iron-clads, I believe, that ever floated, and the men took great pride in keeping them so. (Parker 1883:288-289)

The weak engines, although mostly reliable, did get *Chicora* and *Palmetto State* into trouble occasionally. In particular, as part of their duties, the ironclads acted as pickets near the harbor entrance. They commonly encountered strong tides there. *Chicora* was forced to cast anchor in the face of a two mile-per-hour ebb tide on at least one occasion. Even with the engine at full power, the ship continued to drag (Still 1985:115). In addition, during their one major battle on 31 January 1863, concerns over lack of power prevented *Chicora* from attempting to ram (Figure V.7). James Tomb related the story:

...it was decided to make an attack on the blockading fleet off Charleston. January 30, 1863, we all had steam up, and about midnight proceeded over the bar... We made about seven knots and I think the *Palmetto State* made about eight. About daylight on the 31st, we started for the blockading fleet. The intention was for both ships to ram, as it was felt we could hope to do nothing with them [enemy ships] if they had a chance to get away. ... The *Chicora*...headed for a ship and we in the engine room were waiting for the signal to back full speed, ...[but] we were told we would not ram. ... They feared the *Chicora* would not have power to back clear again. (Campbell 2005:58-59)

Consequently, no enemy ships were captured or sunk and neither ironclad received noticeable damage, although the blockading fleet was driven off. The “raising” of the blockade was only temporary because the Union ships returned to station after the departure of the Confederates.

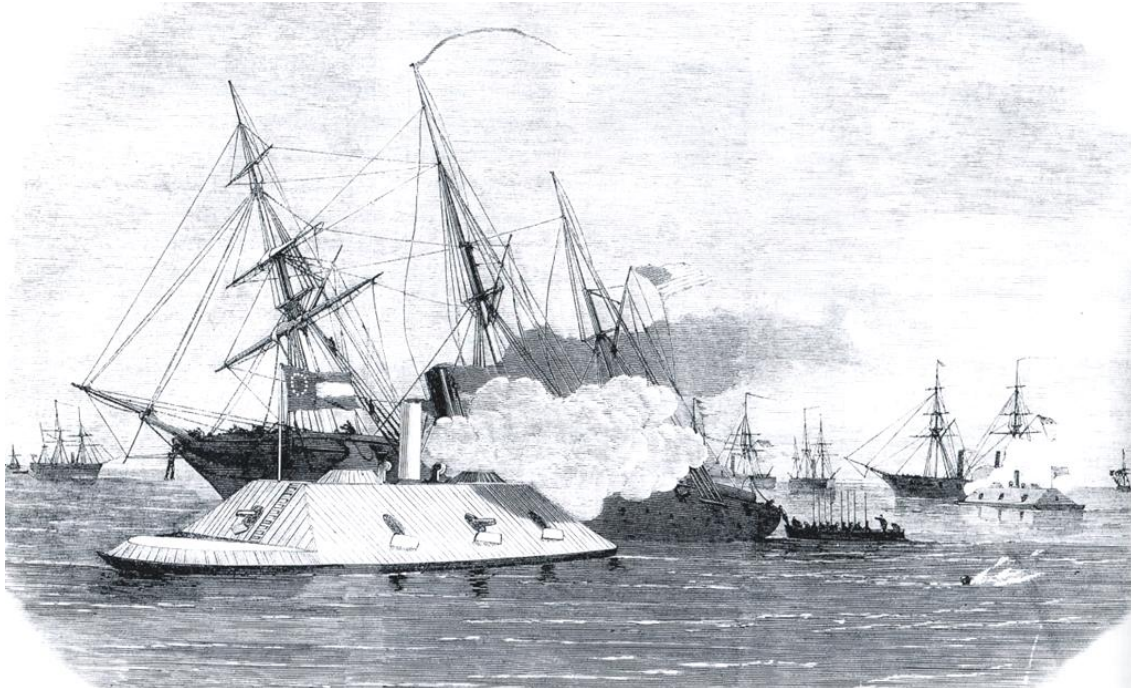

FIGURE V.7. *Chicora* and *Palmetto State* attack Union blockaders on 31 January 1863. (Still 1997:222; from *Illustrated London News* 1863)

Neither *Chicora* nor *Palmetto State* ventured from Charleston Harbor again. They continued to perform picket and general guard duties, all the while in increasingly worse repair. By 1864 the power plants of both were unreliable and nearly worn out. It was reported on 8 January 1864 that *Chicora* "...wants a new boiler" and on 7 September 1864 that "The *Palmetto State*'s boilers are out of order. She goes very slowly" (*Official Records, Navies* 1987 [Ser. 1, Vol. 15]:230,678). Both ironclads lingered on in this manner until the evacuation of Charleston in February 1865, when they were destroyed to prevent capture.

Regarding CSS *North Carolina*

The next *Richmond*-class ironclad to be completed and the first finished in North Carolina was built in Wilmington. *North Carolina* followed the standard Porter design of *Richmond*, *Chicora*, and *Palmetto State* but suffered throughout its career from poor construction and a weak engine. Because of this, *North Carolina* was invariably described as one of the most decrepit vessels in the Confederacy (Still 1985:165).

Perhaps *North Carolina's* greatest problem was its engine, taken from the tug *Uncle Ben* and not capable of moving the ship at more than two or three knots. This was coupled with a lack of copper bottom sheathing. As a result, teredo worms rapidly attacked the ship's bottom as it sat in a defensive position at the mouth of the Cape Fear River. *North Carolina* would spend its entire career in this manner. It was limited from going to sea by deep draft and could only be towed back upriver occasionally in an attempt to kill the marine growth on its hull. Wilmington's first ironclad accordingly served uneventfully as a floating defense (Watts 1999:9).

North Carolina was assigned as part of its crew Third Assistant Engineer Charles S. Peek after its completion in June 1863. He dutifully recorded his experiences on the poorly-built ironclad. Peek's accounts provide a fascinating glimpse of service onboard a particularly unpleasant craft. Serving on such a vessel, he had much to write about, but this retelling will present only the engineering parts. On 1 July 1863, he wrote describing an accidental grounding:

We even got aground on yesterday [sic] on account of the tide being so low and we drawing so much water. After we got aground I bank[ed] my fires and Mr. Freeman took the first watch... We [later, after the tide came in] raised steam and got off. After travelling about two hours we anchored off Smithville, the name of a little town at the mouth of Cape Fear River. We lay all night with our fire bank[ed] and this morning we [illegible] fires and blew off steam. ... When I came out of the engine room last night I was ringing [sic] wet with perspiration [sic]. (Peek 1863: Letter 4)

At the end of the same month, Peek described the drinking occasioned by boredom onboard *North Carolina*: "The two 2nd asst. Engineers on this steamer are very fond of whiskey; they sat up last night until two o'clock drinking..." (Peek 1863: Letter 7). On 12 August: "We expect to go up the river today to rill the worms and barnicles [sic] that have accumulated on our bottom line since we have been in salt water. One of our Engineers was suspended the other day for getting drunk while on duty" (Peek 1863: Letter 8).

Peek's letters do not mention significant details regarding *North Carolina's* machinery again until 6 July 1864, well after the ship had begun to sag and leak noticeably:

We left Wilmington on the 2nd of July and anchored off Smithville for the night of the 3rd. We got a log in our propeller as we were crossing the shoals and had to anchor. When the tide fell we were about 5 ft. out of water, that is we draw about 13 ft., and there was not but 8 ft. on the shoals. I thought that the weight on the shield would crush in and I pack[ed] up my cloths [sic] ready for a start but the old ship stood it well. We were towed off next evening by two tug boats and are now safely at anchor off Smithville. ...I am getting tired of this old ship. I want to get on some ship that can get along without [being] towed everywhere she goes... (Peek 1864: Letter 31)

Two days later on 8 July he wrote: "We have to keep up steam to pump the ship out, it is very hard; we have to keep watch and it also makes the ship very warm" (Peek 1864: Letter 32).

Things were to continue like this for another two months.

Late July 1864 was the beginning of the end for Peek's "old ship." His letter of 24 July described *North Carolina's* sad condition:

Our old ship has nearly played out. We have her moured [sic] head and stern in shoal water that is at low water. She is about 12 inches from the bottom, and she leaks so badly that we have to keep steam up all the time. There is no discipline on her now... (Peek 1864: Letter 33)

A little over a month later in early September 1864, *North Carolina* sank at its moorings off Smithville (Watts 1999:14). Engineer Peek was detached shortly afterward and the Confederates stripped everything valuable from the wreck. The spectacularly unsuccessful career of Wilmington's first ironclad was over.

Regarding CSS Savannah

The last *Richmond*-class ironclad to be completed during the Civil War was constructed in Savannah, Georgia, and named for that city. CSS *Savannah* was probably the best-built of any ship in its class. It was launched on 4 February 1863 and served as flagship of the local naval forces (Holcombe 1978:18). *Savannah's* machinery was furnished by the Columbus Naval Iron

Works but was originally built for a wooden gunboat. It appears by all accounts this power plant performed reliably.

A few different accounts of *Savannah*'s machinery exist as well as two valuable detailed blueprint drawings of the engines and boilers. Some of the most important firsthand details come from official Savannah Squadron correspondence papers now housed at the Manuscript, Archives, and Rare Book Library at Emory University in Atlanta. All the documents generally praise the ironclad's performance, although during trials in July 1863 some troubles were encountered. Much data was gathered and reported during *Savannah*'s trials. They were initiated when Secretary Mallory wrote on 18 July to Flag Officer W.W. Hunter, commander of the Savannah Squadron:

You are requested to have the "Savannah" occasionally run up and down the river, not only to perfect a test of the machinery, but to exercise the Engineers and Firemen and perfect an organization; and you will direct a report to be made thereon. (Savannah Squadron Papers 1863: Box 1, Folder 10)

That same day a report was given listing some of the new ship's design problems. It is particularly interesting because it relates to troubles with the vessel's auxiliary steam systems.

The pipe from the steam pump does not lead sufficiently far aft—as when it "sucks" it leaves 6 ½ inches water in the ship, while with her flat floor endangers the stores aft. The pipe should be extended aft to the pump well and then it will free the ship. (Savannah Squadron Papers 1863: Box 1, Folder 10)

Presumably efforts were made to correct the pump defects before or during trials for they are not mentioned again. Reports were made of *Savannah*'s first successful run before long. Still

1989:16 presented one such account:

A Confederate marine wrote, "Today we took the *Savannah* down river [on a trial trip] to test her engines. She started off beautifully and glided downstream as smoothly as if she were some waterfowl. It was a strange sight to see that huge mass of iron, shooting from the water like the roof of a house, steaming along so like a thing of life".

Teething troubles were soon encountered and unfortunately proved to be serious. Robert F. Pinckney, *Savannah's* commander, wrote to Flag Officer Hunter on 3 August 1863:

While this vessel was returning from the [torpedo] barrier, whither I had run her, in obedience to your order, to try her machinery, the starboard engine became disabled from the breaking of the piston. By subsequent investigation, it has been discovered that the steam-cylinder is also broken. (Savannah Squadron Papers 1863: Box 1, Folder 12)

Hunter accordingly wrote an order the next day for a thorough investigation to be done on the broken engine by the senior engineers of the Savannah Squadron. Recommendations on repairs were also requested. Acting Chief Engineer J.M. Tynan, who had earlier in the war served onboard CSS *Virginia*, made his report to Flag Officer Hunter at the end of 4 August:

SIR: In accordance with your order herewith appended, we have held a strict and careful survey on the engines of the C.S. Steamer *Savannah* and most respectfully submit the following report of their condition for service, of the damage done to the starboard engine, etc.

We are of the opinion that the ship can be worked by the port engine as it is, by careful management. But as there will be some difficulty in starting the engine, in consequence of the liability to stop in the centers, we consider it necessary to have a steamer in attendance to render any assistance that may be required; and for further security, we respectfully recommend that a trial be made at the wharf which will determine whether by some slight alteration of the valve, the working of the engine may not be considerably improved. Other than this we would not advise the engine to be used except in case of great emergency.

The damage done to the starboard engine is as follows, viz: the cylinder, piston head, follower and rings are irreparably broken, outboard cylinder head cracked and piston rod bent. From the appearance of the broken parts of the piston, we are satisfied that—with the exception of about two square inches—it was broken entirely through the middle before being used on this vessel, and are of the opinion that it was done in keying it on the rod before it left the shop. We were shown a rivet 5/8-inch diameter and about 2 1/2 inches long with a head of about 1-inch diameter which according to the statement of the engineers in charge was taken from the inside of the cylinder amidst the fragments of the piston. This rivet in our opinion was the immediate cause of the accident; we suppose it to have been left through the carelessness of some of the workmen in the steam passage of the cylinder, and by the rush of steam or some jar was carried down into the cylinder, and as there was only from 1/4 to 3/8 of an inch clearance between the piston and cylinder head a breakdown was inevitable. Had the piston been perfectly good before steaming, the presence of this rivet in the cylinder would in all probability have caused the same amount of injury to the engine.

The breaking of the cylinder was evidently caused by the parts of the piston broken off being acted on by that part still attached to the rod as the engines according to the

statement of the “engineer of the watch” made two or three revolutions after the occurrence of the accident.

The following repairs are necessary to put the machinery in good working order. Viz: A new cylinder, new piston with follower, rings, etc., a new cylinder head and the piston rod to be straightened.

We think the most expeditious manner of repairing the engine would be by having it done at the “Naval Iron Works” Columbus, GA, where the engines were built. The time necessary to make the repairs will in our judgment be about one month. (Savannah Squadron Papers 1863: Box 1, Folder 12)

This report represents one of the most detailed accounts regarding the functioning of a typical ironclad engine and also reveals the kind of quality-control problems encountered by the Confederacy’s nascent marine engine industry. It was quickly agreed to by both Flag Officer Hunter and Secretary Mallory and the broken engine parts were sent to Columbus.

The repairs presumably went well and *Savannah* was successfully re-powered. There are no further reports regarding the ship’s performance under steam. Among the last accounts relating to *Savannah*’s machinery are entries in the journal of Robert Watson, who served onboard *Savannah* after his transfer from the army. On 1 May 1864, he revealed the severe shortage of coal for the navy, although by that time it was casually accepted: “Took some wood and got up steam and dropped out into the stream” (Campbell 2002:111). On 21 December 1864 and at the very end of *Savannah*’s career Watson reported on the danger of shells entering an ironclad’s smokestack:

...the Yankees opened fire on us from the city. We were not slow in returning the compliment but with what effect I cannot say. The Yankees made excellent shots, nearly every one struck our sides or smoke stack. One shell went down the smoke stack and rested on the grating but did not explode [!] (Campbell 2002:139-140).

The conflict to which Watson refers occurred after the capture of Savannah by Federal troops. The city’s namesake ironclad was left to cover the retreat of the Confederate forces and the destruction of the other Savannah Squadron vessels. Once the gunnery duel ended and the

retreat was known to have succeeded, CSS *Savannah* followed in the path of so many other ironclads and was fired by its own crew (Figure V.8).

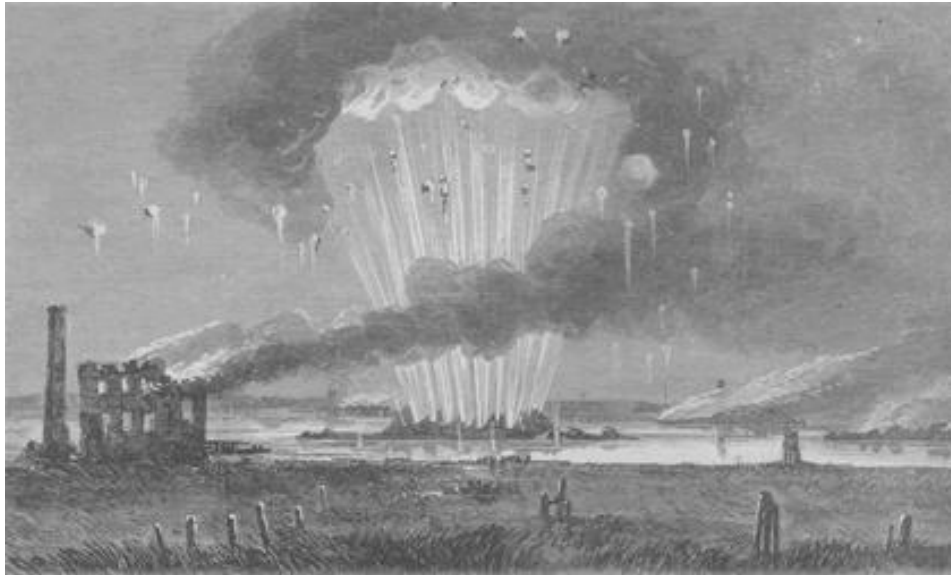

FIGURE V.8. The destruction of CSS *Savannah*, 21 December 1864. (U.S. Army Corps. of Engineers Savannah District 2005)

Regarding CSS *Virginia II*

A few bits of firsthand engineering information regarding the Confederacy's most powerful ironclad and flagship of the James River Squadron, *Virginia II*, have been found. This vessel was designed by Naval Constructor William Graves and built in Richmond with eight inches of iron on its casemate ends and six on its sides (Holcombe 1993:81). *Virginia II* was also supposedly capable of up to 10 knots with its possibly English-built engines, but they proved faulty in the long run (Coski 2005:211). In the end, the new James River Squadron flagship spent most of its career idle, often dealing with machinery problems like the other ironclads defending the Confederate capital.

Three very brief but informative statements concerning *Virginia II*'s steam machinery in service can be found in the *Official Records of the Union and Confederate Navies in the War of the Rebellion*. They range over the course of a year, between February 1864 and February 1865.

Evidence of the hasty completion of the ship can be seen, but there are no significant details regarding the layout of the engines themselves. The only line in this direction is in an informal letter written on 26 February 1864: “She has an engine of nearly 500 horses” (*Official Records, Navies* 1987 [Ser. 1, Vol. 9]:801).

When *Virginia II* was finished in May 1864 it underwent the necessary trials. On 21 June Flag Officer Mitchell telegraphed Secretary Mallory of a problem eerily similar to that encountered by *Savannah* nearly a year earlier:

I was about proceeding down the river, near Howlett’s [a Confederate land battery], when the piston was discovered to be out of order. The cylinder was removed and a chisel found in the cylinder. The engine is now in working order again. (*Official Records, Navies* 1987 [Ser. 1, Vol. 10]:186)

The problem was apparently not as severe as that onboard *Savannah* but again showed the problems inherent with hasty construction and a general lack of experience many Southern workers had with steam machinery. It was fortunate that the James River Squadron instituted weekly machinery inspections under its chief engineer, Henry X. Wright. On 7 July 1864, for instance, he wrote to Flag Officer Mitchell:

SIR: I have the honor to report that at general inspection held on board the C.S.S. Virginia [II] this day, that after a very careful and thorough examination of the engines, boilers, steam pumps, and the appendages, under steam, I found everything in good order and condition and in a very high state of efficiency. (*Official Records, Navies* 1987 [Ser. 1, Vol. 10]:718-719)

Despite its apparent cleanliness and efficiency, the hasty construction of many of *Virginia II*’s iron components caused at least one safety concern. The temporary commander of the ship in February 1865, Lieutenant John Dunnington, wrote on the 5th: “On berth deck the force pumps, intended to use in case of fire or when the crew could not go outside of shield, have never been completed” (*Official Records, Navies* 1987 [Ser. 1, Vol. 12]:179). Fortunately, this lack of a backup pumping system was never put to the test.

Near war's end a good account of the interior layout of a Confederate ironclad was written by an Irishman, Thomas Conolly, who visited *Virginia II* in late March 1865. This was just a week before the evacuation of Richmond on 2-3 April (Coski 2005:180). Conolly's account is revealing in that it makes clear just how modern and well-maintained many Civil War ironclads were compared to other vessels despite their engineering and climate control problems. Unfortunately, no detail is given on *Virginia II*'s machinery spaces:

[We went] thro a small iron port hole where we saw the thickness of her iron-sides lined with oak about 4 feet [thick] when inside the great guns one astern of gigantic proportion d[itt]o for'ad & 3 [gunports] at either side light & air coming thro thick iron bars at top sloping inwards garnished with all the gun requisites tower tier filled with long steel soled shot about 12 inches each. Middle supports covered with racks of six & ten shottng rifles in fine order men & officers sauntering about quietly—Thence to mens quarters down a hatchway for'ad all in order with a cooking stove full of excellent dinner surrounded by mess boxes wh[ich] when opened had their tin plates, cups knives salt pepper &c in good array with the n[umber] of rations for each mess in middle! All as nice as any man of war hammocks all stowed along inside making a pleasant couch to lean against—Men all standing round at attention & all neatly clad in confed: grey shirts. Then to engine room at other end—Thro wardroom & quarters Ad(mirals) sleeping room all dark but bright & clean when lighted up. (Lankford 1988:65-66)

Virginia II ultimately suffered the same fate as most other Confederate ironclads. The strongly-built and powerful ship was blown up to prevent capture.

Regarding CSS *Columbia*

This vessel was the last ironclad to be completed at Charleston but its career was cut drastically short due to human error. *Columbia* was a radically-altered sister ship of the more famous *Tennessee*, carrying six inches of armor and six guns in an improved layout on approximately the same draft (Holcombe 1993:73). *Columbia*'s completion was severely delayed by material and labor shortages like virtually all other late-war ironclads. Laid down in December 1862, this powerful ironclad was not launched until 10 March 1864 and not commissioned until January 1865 (Holcombe 1993:88-89). During a trial trip to test *Columbia*'s

brand-new machinery from the Columbus Naval Iron Works the ship ran hard aground on a sunken wreck and had to be abandoned. Third Assistant Engineer E.A. Jack, formerly assigned to both CSS *Virginia* and *Arkansas*, recounted the unfortunate incident:

At last the engines and boilers were ready for the trial, and there was a gathering of officers from other vessels of the fleet. Steam was gotten up by the force sent from Columbus, Ga. by Chief Engr. Warner, who had constructed the machinery at the Govt. works at that place, and his men were at the engines. Mr. [Virginus] Freeman, as Fleet Engineer, was the supervising officer, and I a looker on and, to some extent, an assistant to him also. There was [sic] some drinkables and eatables on the spread in the wardroom, too much of the drinkables I fear.

Not long after we got underway, a valve was opened by one of the shop hands, which came near to causing the loss if not the explosion of one set of the boilers. The fires under these had to be hauled, because they were nearly empty of water. After the fires were hauled and the boilers were cooled they were refilled and fire started again. When this bad piece of engineering occurred, the ship was steaming to reach a shoal near the mouth of the stream while there was enough water to pass over. The loss of steam and slow consequent speed of the engines caused her to miss the tide, and when on the way back to her moorings, she was run upon a sunken vessel, and hanging there, was left by the tide, and leaking in her hull, became a wreck. (Flanders and Westfall 1998:35)

It can be readily seen that even the most experienced steam engineers could make catastrophic mistakes, especially when supervising machinery they were not familiar with. In this case it cost the Confederacy one of its best-built and most powerful ironclads. After the fall of Charleston in February 1865 the U.S. Navy made a survey of the wrecked *Columbia* and ultimately succeeded in refloating it. The valuable hull was eventually sold for breaking up.

Regarding CSS *Missouri*

An ironclad was appropriately the last Confederate vessel to surrender in home waters on 3 June 1865 (Still 1985:226). This vessel, CSS *Missouri*, was unique in that it was the only centerwheel ironclad completed in the South despite a lack of facilities, materials, and labor in the trans-Mississippi region where it was built (Holcombe 1993:108). Extensive research by Katherine B. Jeter has resulted in two important documents which collate a number of primary sources on *Missouri*. The most important of these for the purposes of this work are the letters of

the ironclad's devoted commander, Lieutenant Jonathan H. Carter. Carter's notes spanning the majority of *Missouri's* largely uneventful career reveal much about operating a centerwheel ironclad on the Red River in Louisiana toward war's end (Jeter 1987:263-288).

Overseeing the gathering of materials and construction of *Missouri* on the trans-Mississippi frontier was a challenging task for Carter and he was especially anxious about the installation of his ironclad's machinery. He wrote to Secretary Mallory on 2 February 1863: "The contractors have purchased a steamboat [possibly *Grand Era*, but this matter remains unresolved] with suitable machinery. The price paid was sixty five thousand dollars" (Jeter 1996:6). He continued on 4 April: "The machinery and boilers are on board and will be put in position immediately" (Jeter 1996:31).

Apparently there was some problem causing a significant delay in installation, for on 21 April Carter wrote:

I am very anxious to get her machinery in position before she leaves here, as a steamboat to aid her will then be unnecessary. The cladding is being put on as rapidly as possible, and within three or four weeks I hope to have her machinery in position. (Jeter 1996:39-40)

He continued to report to Mallory fairly regularly, writing on 29 April: "The boilers are in position, and the remainder of the machinery will be put in place as rapidly as possible" (Jeter 1996:40-41). This was finally done and by June 1863 construction was complete enough for Carter to begin to appraise *Missouri's* design. On the 15th, he wrote: "As I have stated in a former letter, I think the centre wheel plan will prove slow, notwithstanding the power is more than sufficient to turn the wheel" (Jeter 1996:49-50). The ship was apparently ready for trials by that time.

On 20 June 1863 the first of many letters from Carter to various Southern naval leaders regarding his new ironclad offered testimony of *Missouri's* operational characteristics: "On the

17th inst., the 'Missouri' made a trial trip; the rate of speed obtained was six miles per hour upstream" (Jeter 1996:51). On 21 June he wrote a detailed order to two engineers participating in *Missouri's* completion:

You will answer the following interrogatories in regard to the engines, boilers, and machinery of the C.S. Str. "Missouri," now being constructed at this place [Shreveport, Louisiana] by Messrs. Moore & Smoker.

Int. 1st. Are the boilers of said vessel sufficiently braced?

" 2nd. Has she the necessary "mud valves"?

" 3rd. Should the small engine for working the capstan be over-hauled?

" 4th. Are there any pumps for pumping out the ship?

" 5th. Do the "exhaust valves" of the engines require grinding?

" 6th. Are the steam pipes so short as to require what is termed a "slip" or "expansion" joint?

" 7th. Is the Main Shaft sufficiently strong, and is it as good as could be done here?

" 8th. Are the joints of the Steam pipes sufficiently tight to prevent leakage?

" 9th. Do the cocks or pipes for supplying the boilers with water leak badly or is there any danger to be apprehended that said pipes will break or burst?

" 10th. Is the cock or pipe for supplying the deck pump with water necessary, and should the water for supplying said pump be furnished by the cocks and pipes that supply the boilers? (Jeter 1996:54-55)

These questions reveal a fairly complete picture of a Confederate ironclad's typical steam machinery components, but because *Missouri* was built using riverboat parts there were necessarily differences between it and the harbor ironclads of the coasts. In any case, Carter apparently received satisfactory answers, for his ship was in full operation by autumn 1863.

Letters pertaining to *Missouri's* steam plant in actual service began on 19 September when Carter wrote to Mallory: "The rate of speed of the 'Missouri' is 5 ½ miles per hour [without guns]" (Jeter 1996:67). Carter was optimistic that even with the weight of guns, which he had had great difficulty in procuring, *Missouri* would steam better once it was on an even keel. He continued to find and fix small problems in the meantime: "The main bilge pumps are not as complete as should be for want of pipe" (Jeter 1996:68) and "A small boiler and engine has been placed in the fire room which works a steam fan, steam capstan and steam pumps"

(Jeter 1996:70-71). *Missouri* was one of only three Confederate ironclads (*Atlanta* and *Tennessee* were the others) known to have had forced-draft fans installed in an effort to improve their steaming qualities. It appears that *Missouri*'s speed actually was increased by this addition.

Carter's greatest difficulty in operating on the Red River was obtaining fuel. Many of his letters to superiors beginning in December 1863 relate to gathering supplies of wood. On 2 December he wrote: "I would be glad... [to] have a lot of pine knots hauled to the river at some point below Alexandria for the use of the 'Missouri'" (Jeter 1996:78) and explained further in another letter that same day: "Coal is not to be had and wood must be used which will be supplied by the 'Cotton' [a wooden paddlewheeler and *Missouri*'s tender]" (Jeter 1996:78-79).

Missouri remained trapped for nearly a year in the upper Red River by obstructions, low water, and lack of fuel. It could only steam back and forth occasionally. On 20 September 1864, Carter wrote once again concerning his lack of adequate fuel and the important services of the steamer *Cotton*: "The 'Missouri' can only carry wood for one day and should it become necessary to use her [in battle] the services of the 'Cotton' will be indispensable" (Jeter 1996:150). Unfortunately for its eager commander, *Missouri* never saw action and waited out the waning days of the Civil War near Alexandria, Louisiana.

In late March 1865, Carter's last letters pertaining to the functioning of his ship's machinery reveal that despite all the hardships *Missouri* performed well. Whether this would have been the case under the trying circumstances of battle is open to question but it is apparent how much Carter attended to the needs of his ship. He especially had to maintain the steam pumps, for *Missouri* leaked excessively because of the green wood used in its construction. On 24 March 1865, with the Civil War all but over in the East, Carter wrote to one of the engineers who had participated in installing *Missouri*'s machinery: "Will you do me the favor to cast and

fit a sliding valve for the steam pump of the ‘Doctor Engine’ on board the Steamer ‘Missouri’?” (Jeter 1996:175).

Despite problems with leaks, *Missouri* continued to function well until the end. The ship was finally forced to surrender in June 1865. With two months of idleness yet to go on 5 April 1865, Carter had summed up the functioning of his ironclad’s surprisingly reliable power plant: “The performance of the ‘Missouri’ exceeded my expectation. Her speed is much greater than I expected. She has made as much as ten miles per hour with a current of from two to three miles. Her machinery works well” (Jeter 1996:183-184). This last statement was perhaps one of the highest compliments that could be given regarding steam engine operations onboard any Confederate ironclad.

Conclusions

It can readily be seen that existing accounts regarding service in the engineering departments of the Confederate ironclads are patchy and scarce, but do offer some fascinating glimpses into daily life onboard. Conditions encountered by naval engineers in the early days of steam power were hellish, and required nearly herculean levels of strength and endurance by today’s standards. In battle, it has been seen that operating conditions were even worse. This chapter has conveyed the actual experiences of the engineers who served in those conditions and presented them together for perhaps the first time. Firsthand history such as this, and the men who fought doggedly in the midst of it, deserve to be remembered in such an unflinching manner. Such was the caliber of the service they gave.

CHAPTER 6: ENGINEERING SPECIFICATIONS OF 27 CONFEDERATE IRONCLADS

Contrary to popular belief, there is a fair amount of technical data available concerning many of the Confederate ironclads. As discussed briefly in Chapter 1, the data is rather scattered but a working picture of engineering layouts is obtainable. The goal of this chapter is to list all relevant machinery specifications in a concise and comprehensive manner.

By far the most valuable sources are government works: *Records of the Union and Confederate Navies in the War of the Rebellion* (originally printed 1894-1922) and record groups 19, 45, 56, and 109 in the National Archives in Washington, DC, and College Park, Maryland. Finding specific data in these extensive collections requires some intensive searching but is nonetheless revealing. This is particularly true of some of the lesser-known ironclads.

Another very valuable source of information for much of the data presented in this chapter is the collections of the Port Columbus Civil War Naval Museum in Columbus, Georgia. Columbus was the most important Confederate location for the manufacture of marine steam machinery during the Civil War. This history still shows both in the town itself and the museum collections. Among the most valuable items are several detailed engineering drawings of steam engines manufactured for ironclads.

Finally, Port Columbus offers one more item that is essential viewing for the Civil War steam engine researcher. The two horizontal single-cylinder direct-acting engines of the wooden gunboat CSS *Chattahoochee* are preserved on the museum grounds. These engines are very similar to those put into many ironclads and offer a firsthand glimpse at an actual Civil War steam plant. The only other power plant preserved from a Civil War vessel is that of the Union ironclad gunboat USS *Cairo* in Vicksburg, Mississippi. The single-cylinder inclined high-pressure engines of *Cairo* were very similar to those used onboard the Confederate centerwheel

ironclad CSS *Missouri*. Therefore, data regarding the extant engines of both *Chattahoochee* and *Cairo* will be presented in this chapter as each pertains to one or more Confederate ironclads discussed in the following pages.

Each of the 27 Confederate ironclads covered by this thesis; the conversions, early non-standard types, *Richmond*-class, *Tennessee*-class, the *Charleston*-class ironclads designed by William Graves, large sidewheelers, diamond hull types, and the unfinished examples (*Mississippi*, *Jackson*, *Milledgeville*, and *Wilmington*) will be briefly discussed with detail regarding machinery specifications. These data include engine number and type, dimensions (in diameter and stroke), and notes on unusual arrangements. Similar data will be presented on boilers and auxiliary equipment if known. Vessels are presented in their respective groupings and arranged chronologically according to launch date.

CSS *Manassas* (ex-*Enoch Train*)

Manassas was the first armored ship to serve in the Civil War but began its career as the Boston Harbor towboat *Enoch Train* in 1855 (Holcombe 1993:21). The vessel was strongly-built with fine lines and completed by the famous clipper ship builder J.O. Curtis at his Medford, Massachusetts, yard. The steam machinery came from Harrison Loring's famous City Point Works in South Boston (Silverstone 2001:152). In 1859, *Enoch Train* was brought to New Orleans for towing and dredging work. The ship's powerful engines driving twin screws made it ideal for these operations in the Mississippi and were ultimately what led a group of New Orleans businessmen to purchase the vessel for conversion into an ironclad ram in 1861. Steamboat captain John A. Stevenson supervised *Enoch Train*'s conversion at the Algiers, Louisiana, shipyard of John Hughes & Co. beginning in May 1861 (Campbell 2006:48).

Enoch Train was renamed *Manassas* for the recent Confederate victory in Virginia. It was ultimately razed down to main deck level and given a convex wooden shield covered with railroad iron; only one forward-firing gun was placed within it (Holcombe 1993:22). Figure VI.1 shows a rough sketch of the ironclad's unusual appearance. The ship's bow was also restructured into a ram. Unfortunately, the addition of the extra weight reduced *Manassas*' speed considerably; a maximum of eight knots was only obtainable when steaming with the river current (Holcombe 1993:22).

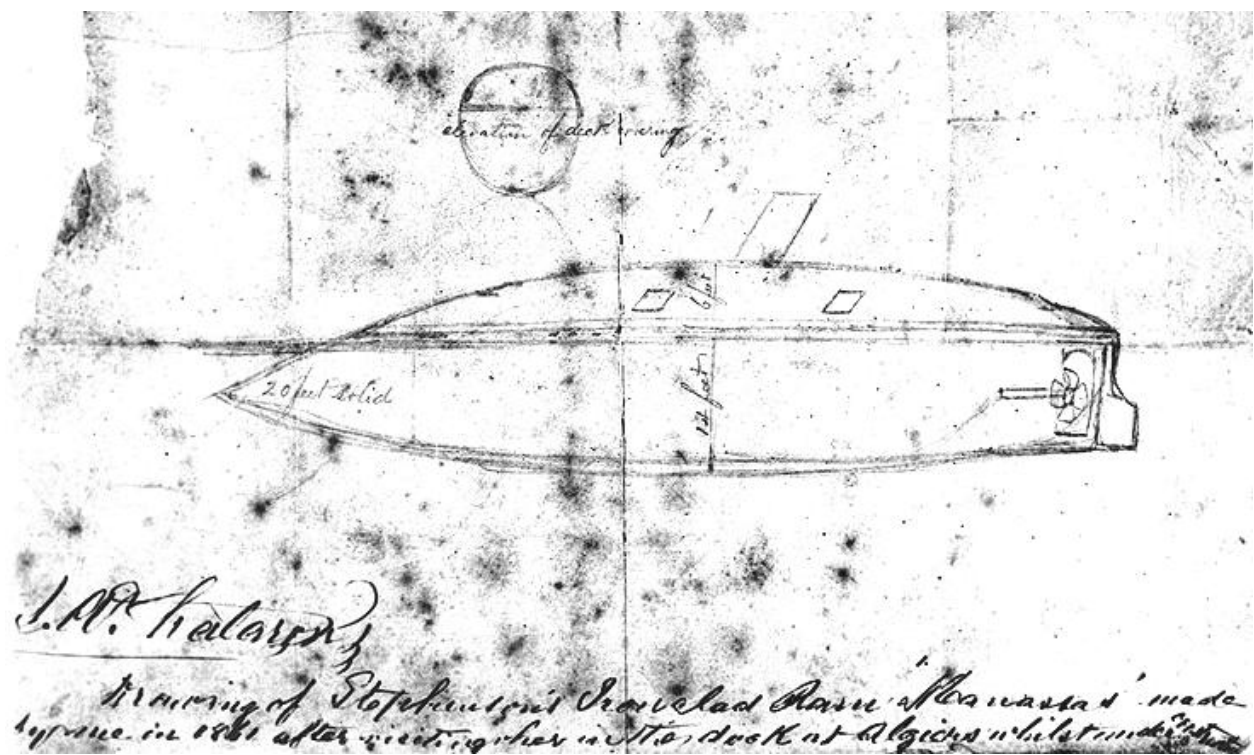

FIGURE VI.1. Rough 1861 sketch of *Manassas* by J.A. Chalarnon in 1861. He had visited the ship while it was being converted at Algiers, Louisiana. (Online Library of Selected Images, Naval Historical Center, Department of the Navy, Washington, DC, 2012)

A fair amount of detail regarding *Manassas*'s machinery arrangement and specifications exists, although no technical drawings of it are known. The ex-towboat's powerful and unusual (for the 1850s) twin-screw propulsion system drew its share of comments, especially during an 1883 Supreme Court case involving patent infringement on dredging methods. One of *Enoch*

Train's former operators provided details on the ship's machinery during the hearings (U.S. Supreme Court 1883:107 US 192, *Atlantic Works v. Brady*).

As built, *Enoch Train* had a registered tonnage of 385, a length between perpendiculars of 128 feet, and a maximum beam of 28 feet. As CSS *Manassas* these measurements were increased to 143 feet overall, 33 feet maximum beam, and an estimated 10.5-foot draft (Holcombe 1993:21-22). The ship was powered by two single-cylinder inclined direct-acting engines, each driving one three-bladed screw. The engines were low-pressure condensing with cylinder diameters of 36 inches and stroke of 34 (some sources say 32) inches, while the screws were about 9 feet in diameter. *Enoch Train* also was fitted with one doctor engine of unknown size and later, a large wrecking pump for its pre-Civil War dredging work. All the machinery was powered by one or two low-pressure boilers of uncertain type and size. (Mariners' Museum MS006 [Folder 49]:1; U.S. Supreme Court 1883:107 US 192, *Atlantic Works v. Brady*)

It appears that no modifications were made to *Enoch Train*'s machinery during conversion into *Manassas*, although it is only possible to speculate on this since no detailed records are known to exist. One interesting possibility is that *Manassas*'s ability to pump high-pressure steam and scalding water over the top of the shield for repelling boarders was a result of modifications to the powerful wrecking pump installed during the 1859 dredging operations. Future archaeological excavations of the Mississippi River wreck site may reveal new data.

CSS *Virginia* (ex-USS *Merrimack*)

The story of CSS *Virginia*, more commonly known by its original U.S. Navy name *Merrimack*, has been well-told elsewhere. This most famous of Confederate ironclads has been the source of exhaustive study and fortunately its machinery systems are accordingly well-known. The ship was built at the Charlestown Navy Yard in Massachusetts as the first United

States steam frigate USS *Merrimack* from July 1854 to February 1856 and made history as the first auxiliary steam-engined propeller-driven frigate in the world (Amadon 1988:9). Its design was copied in five sister ships but different engine types were used for each.

Merrimack was powered by four vertical watertube boilers connected to two horizontal single-cylinder return connecting rod, or “back-acting,” engines turning a single screw. This machinery was in reality only intended to aid in port maneuvers in an auxiliary role to the frigate’s 48,757 feet of canvas. *Merrimack* could make 10.656 knots underway using both sail and engines, but only 6 using just engines (Park 2007:48).

The massive power plant installed on *Merrimack* was built by West Point Foundry in Cold Springs, New York, one of the largest and most experienced manufacturing facilities in the United States before the Civil War. *Merrimack*’s engines were designed by West Point superintendent Robert P. Parrott under inspection of Chief Engineer of the U.S. Navy William H. Shock, but reflected the relative youth of steam engine design despite the collaborative efforts of some of North America’s foremost steam engineers (Bathe 1951:4). There were serious defects that severely hampered *Merrimack*’s performance during its five-year service prior to being laid up for a comprehensive overhaul at Norfolk in February 1860 (Amadon 1988:16). The primary sources of trouble appear to have been poor vacuum in the cylinders due to air leaks, poor arrangement of the air pumps and condensing portion of the machinery, and excessive vibration at speed (Park 2007:49-50). It was also eventually revealed that the engines were quite underpowered for the size of the ship (Bathe 1951:5).

Merrimack’s layup at Norfolk resulted in the burning and scuttling of the vessel as Union forces abandoned the shipyard to the Confederates on 20-21 April 1861. Luckily for the Southerners, the scuttling preserved the lower half of the hull and prevented the machinery from

being destroyed by fire. The inability of the Confederacy to manufacture adequate steam machinery at the dawn of the Civil War directly led to the decision to convert *Merrimack* into the ironclad ram CSS *Virginia* in 1862 despite the ship's previous lack of effective power and reliability. The burned-out hulk was raised and rebuilt into the prototype Confederate casemate ironclad and the power plant was repaired as best as possible under the circumstances. Considering the inherent machinery defects and traumas suffered from scuttling, it is surprising that *Virginia* performed as well as it did during its brief career.

As built, *Merrimack* displaced 3,211 tons fully loaded with an overall length of 275 feet, a beam of 56 feet 6 inches, and a draft of about 24 feet (Amadon 1988:9). After conversion to CSS *Virginia* these measurements changed to 3,500 tons; 280 feet 9 inches in overall length; 51 feet 2 inches in beam; and a depth of hold equal to 21 feet 5 inches resulting in a draft of about 22 feet (Holcombe 1993:21). The machinery installed in this hull included 4 Martin vertical watertube boilers (Figure VI.2) 15 feet high, 14 feet wide, and 12 feet deep weighing 28 tons apiece (Amadon 1988:9). Brass watertubes, each 2 inches in diameter, 39 inches long, and 700 in number per boiler effectively transferred heat while a strong double-riveted iron shell plate 0.375-inch thick protected the whole assembly, "...except the tube plates which were 1/2 inch thick" (Bathe 1951:6). The boilers operated at a maximum pressure of 16 PSI and had a total aggregate heating surface of 12,537 square feet (Bathe 1951:6).

Each of *Merrimack*'s boilers was equipped with one feedwater heater under the floor plates, mercurial steam pressure gauges, simple lever safety valves, and at least one glass pressure gauge. In addition, the ship was fitted with two eight-inch diameter Worthington duplex pumps used for supplying boiler feedwater, pumping the bilges, or fighting fires. The 2 massive engines were low-pressure horizontal back-acting and jet-condensing with a cylinder diameter of

72 inches and a stroke length of 36 inches. Each cylinder was connected to the 14.5-inch diameter crankshaft by twin 7-inch diameter piston rods. The air pumps were 42 inches in diameter with a 27-inch stroke, while the steam pipes were 18 inches in diameter. The engines could not be operated independently. Average operating pressure for *Merrimack*'s engines was 25 PSI at about 46 RPM and reverse gearing was accomplished with Stephenson's link motion. Total gross effective horsepower (HP) was estimated at 869 on the propeller shaft with an estimated requirement of 103 HP just to turn the engines over. A further 65 HP was reputedly lost due to friction on the propeller shaft. Figures VI.3-VI.5 show original drafts of this massive iron assembly. (Bathe 1951:4-6)

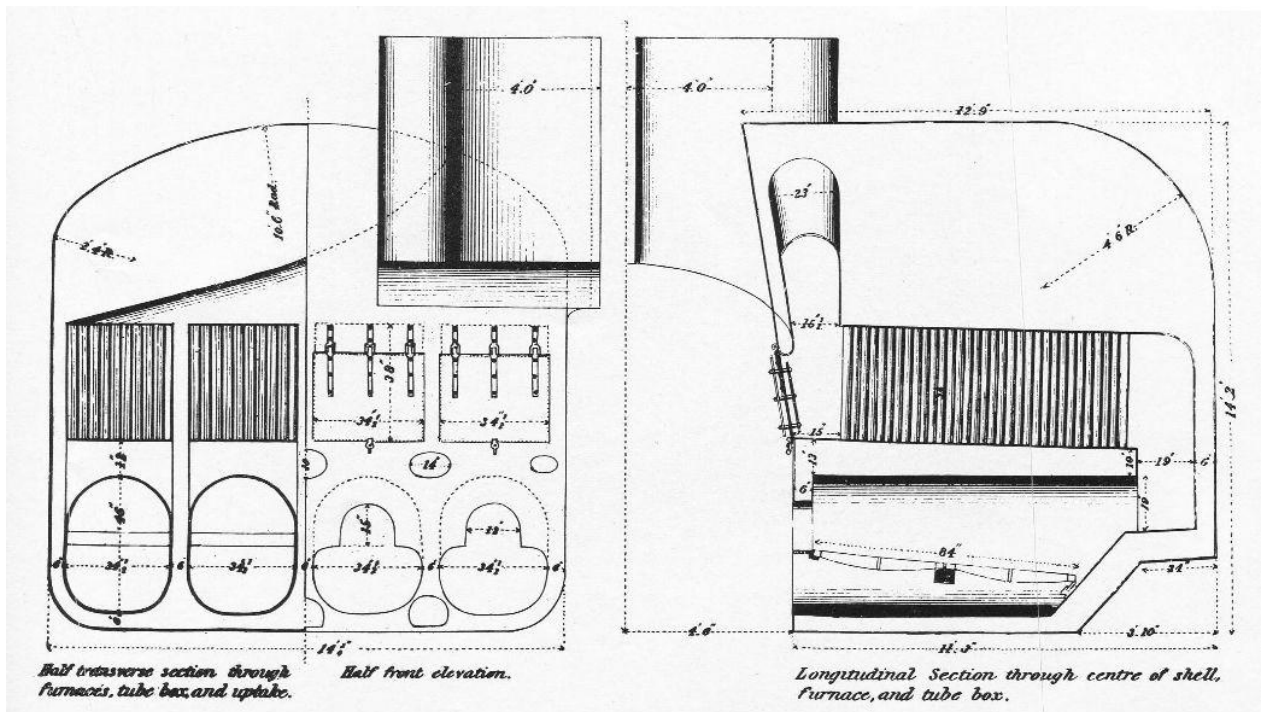

FIGURE VI.2. Engineering diagram of a Martin vertical watertube boiler like those placed in USS *Merrimack* / CSS *Virginia* (Bathe 1951: Plate II)

Arrangement of *Merrimack*'s propulsion system was also unique due to the unusual type of propeller employed. The single wrought iron propeller shaft was forged in 2 sections 30 feet long and 13.5 inches in diameter which turned a massive 17-foot 4-inch diameter 2-bladed

screw. This particular design was patented by the Englishman Robert Griffiths in 1849 and featured adjustable blades for aid in sailing quality. It also allowed for removal of the propeller while underway (Bathe 1951:7).

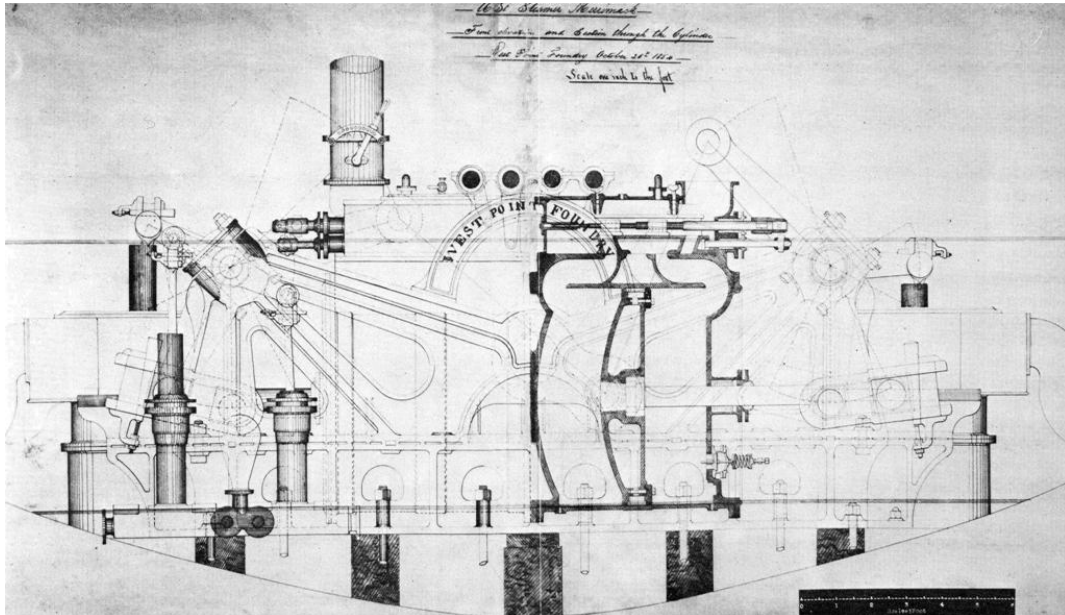

FIGURE VI.3. Engineering diagram of *Merrimack* / *Virginia*'s horizontal back-acting engines. Unfortunately, the connecting rods and links are quite faint. The caption reads: "U.S. Str. Merrimack—Front elevation and section through the Cylinder—West Point Foundry—October 26, 1854—Scale one inch to the foot." (Amadon 1988:12)

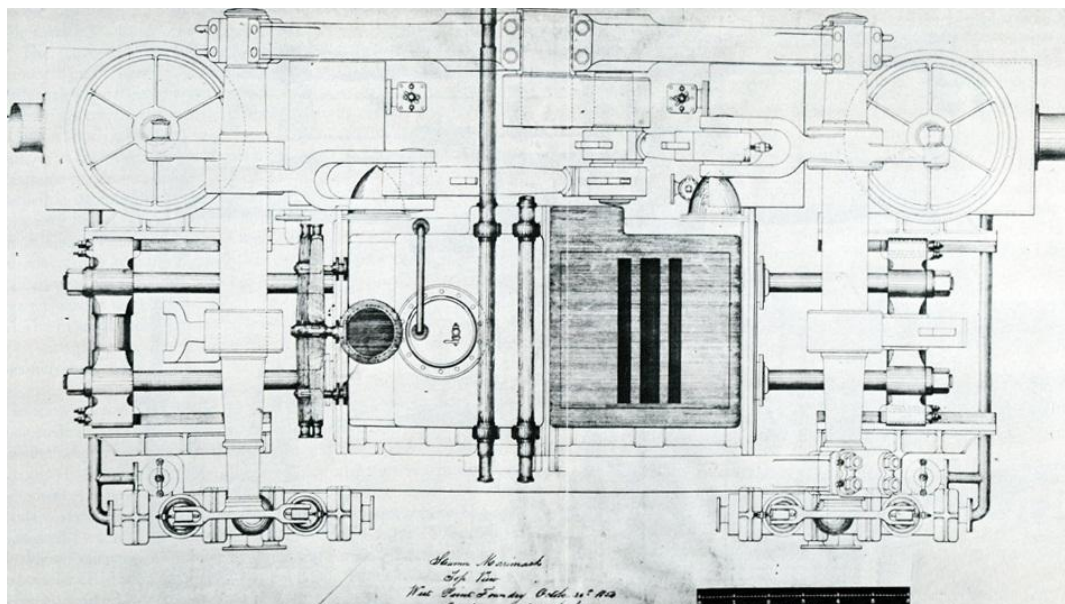

FIGURE VI.4. "Steamer Merrimack—Top View—West Point Foundry—October 26, 1854—Scale one inch to the foot." The cylinders are at the bottom, with the connections to the single propeller shaft and condensers at top. (Amadon 1988:13)

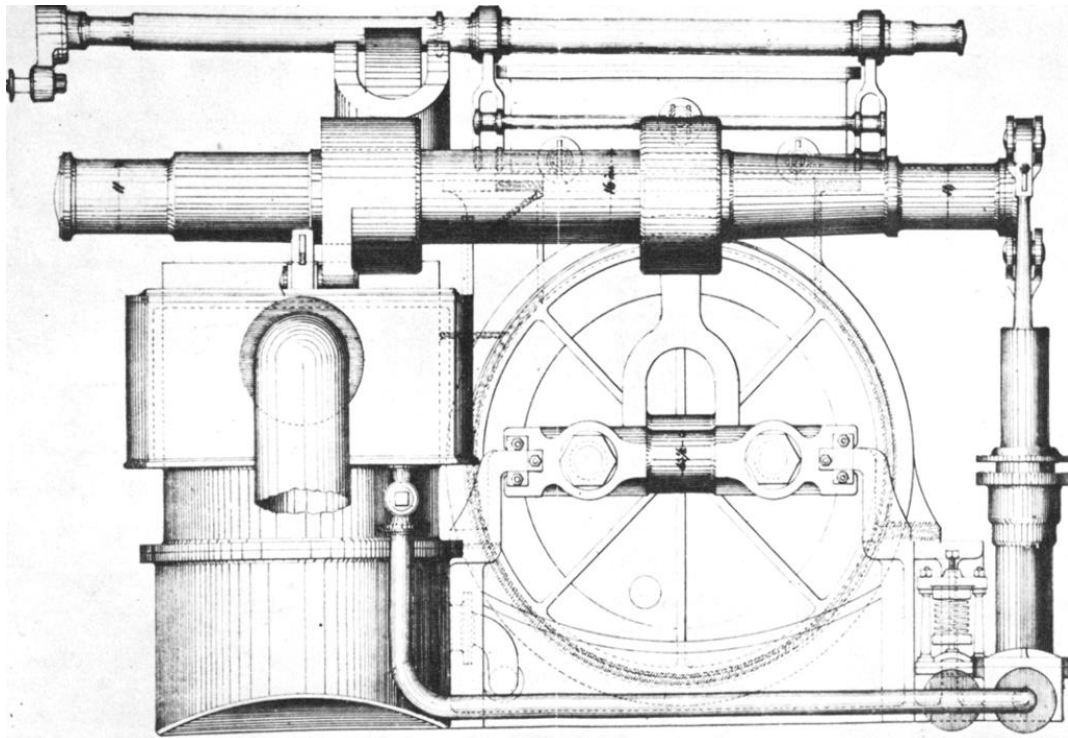

FIGURE VI.5. End view of one of the cylinders showing double piston rods and connecting rods, with air pump at right and condenser at left. (Amadon 1988:14)

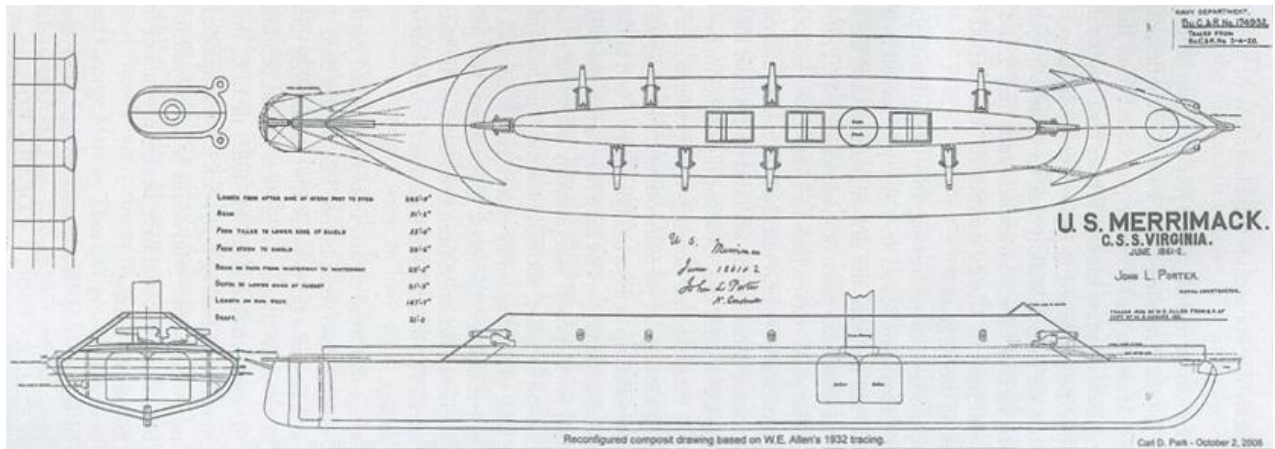

FIGURE VI.6. John L. Porter's plans of *Virginia*, reconfigured and redrawn by Carl D. Park, 2005. (Park 2007:74)

CSS *Baltic*

Many details of this ship's prewar service history and conversion remain obscure. A large portion of information on *Baltic* comes from the "*Baltic Papers*" compiled in 1938 by Clyde E. Wilson and held in the Alabama State Archives, but all of the relevant technical detail regarding

the steam machinery can be found in Union survey reports after the vessel's capture. *Baltic* was apparently built in Philadelphia for the Southern Steamship Co. in 1860 but the manufacturer of the ship and its machinery is not known (U.S. Navy Department 1963 [Vol. 2]:502). As built, *Baltic* was a sidewheel river towboat 176.5 feet in length, 37.3 feet in beam, and 7.6 feet in depth of hold (Holcombe 1993:24). The vessel served as a cotton lighter on Mobile Bay prior to its 1861 purchase by the Alabama state government (Still 1985:80).

After Alabama's secession, the state formed a committee for the purchase of a vessel to be converted into an ironclad. By 13 December 1861, the committee had followed the required specifications for a suitable vessel and purchased "...the good Steamboat called 'The Baltic' her boilers, Engines Machinery, tackle, Apparel and furniture" for the sum of \$40,000 (Wilson 1938:2). Conversion of the small lighter into an ironclad commenced quickly but little is known of the exact layout other than that it was cottonclad aft (*Official Records of the Union and Confederate Navies in the War of the Rebellion* 1987 [Ser. 2, Vol. 1]:248). Figure VI.7 presents the only known contemporary depiction of Mobile's first armored vessel.

Baltic's dimensions as converted were increased to 186 feet in overall length, 38 feet in beam, a draft of about 7 feet, and a displacement of 624 tons. The ship's bow was lengthened and strengthened into a ram and four heavy guns were equipped. All of this extra weight, combined with that of the armor, left *Baltic* very slow and unmanageable. To compound the problem, rotteness set in and the ironclad was relegated to sideline duties only (*Official Records, Navies* 1987 [Ser. 1, Vol. 22]:226).

Baltic had had its armor removed and was in an advanced state of disrepair by the time of its surrender to the U.S. Navy at Nanna Hubba Bluff on the Tombigbee River on 10 May 1865. A Union survey of the ship in June provided relevant data on the condition of the machinery,

which was apparently in good condition except the boilers. *Baltic* was powered by four “very old and leaky” horizontal double-flued boilers with flues 15 inches in diameter; each boiler was 24 feet long and 3 feet in diameter. The furnaces could burn either wood or coal in keeping with standard practice of the day and the ship could carry 75 tons of fuel total. *Baltic* also carried a doctor engine for pumping and boiler feedwater purposes. (*Official Records, Navies* 1987 [Ser. 1, Vol. 22]:226)

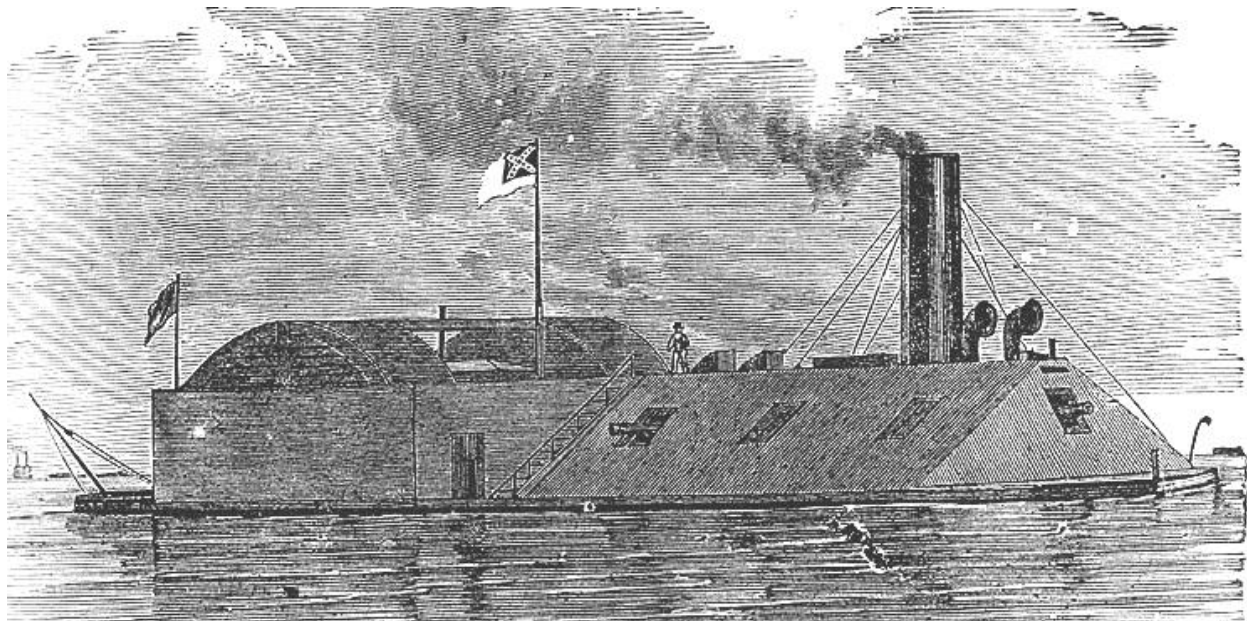

FIGURE VI.7. Contemporary engraving of *Baltic*. The level of accuracy is uncertain due to few existing descriptions of the vessel as converted. (Online Library of Selected Images, Naval Historical Center, Department of the Navy, Washington, DC, 2012)

Baltic's two engines were described as inclined non-condensing, "...of the usual Western river type and arrangement." Cylinder diameter was 22 inches with a 7-foot stroke, each independently turning a 29-foot diameter, 8-foot wide paddlewheel. All of this machinery was apparently in surprisingly good order considering the overall condition of the ex-ironclad. It was initially recommended by the Union surveyors that *Baltic* would once again make an excellent towboat with repairs to the hull, woodwork, and boilers. Nothing ever came of the proposal and the worn-out vessel was eventually sold (*Official Records, Navies* 1987 [Ser. 1, Vol. 22]:226).

CSS *Arkansas*

This early-war ironclad was one of the first vessels laid down as part of Mallory's shipbuilding program. *Arkansas* and its never-completed sister ship *Tennessee* (not to be confused with the later, more famous *Tennessee* of Mobile Bay) were intended from the outset as offensive river and seagoing warships (Holcombe 1993:39). As such, *Arkansas* combined a heavy armament and several hybrid design features. These advantages all came to naught in the face of *Arkansas*'s unreliable engines which directly caused its loss.

Construction on the two ships began in October 1861 at a landing near Fort Pickering below the strategically important Mississippi River town of Memphis, Tennessee, under contract to steamboat builder John T. Shirley (Still 1985:62). On 24 April 1862, the first of the two, christened *Arkansas*, was launched and hurriedly put in preparation for towing to a safer location. Just days later, the sister ship *Tennessee* was burned on the stocks as Union naval forces attacked Memphis. *Arkansas* was meanwhile towed up the Yazoo River to Greenwood, then Yazoo City, Mississippi. It was speedily completed despite a severe lack of materials, labor, and the general difficulties associated with remote location.

Arkansas was 165 feet in length between perpendiculars, 35 feet in molded beam, and 12 feet in depth of hold. The design was unusual in that the casemate had vertical sides and the fore and aft flush decks were equipped with low armored bulwarks (Holcombe 1993:40). Below the waterline, the hull was deep and rounded like that of a seagoing vessel; Isaac Newton Brown, *Arkansas*'s commander, wrote that the ship "...appeared as if a small seagoing vessel had been cut down to the water's edge at both ends, leaving a box for guns amidships" (*Battles and Leaders of the Civil War* 1991 [Vol. 3, Part 2]:572). Figure VI.8 presents a contemporary sketch.

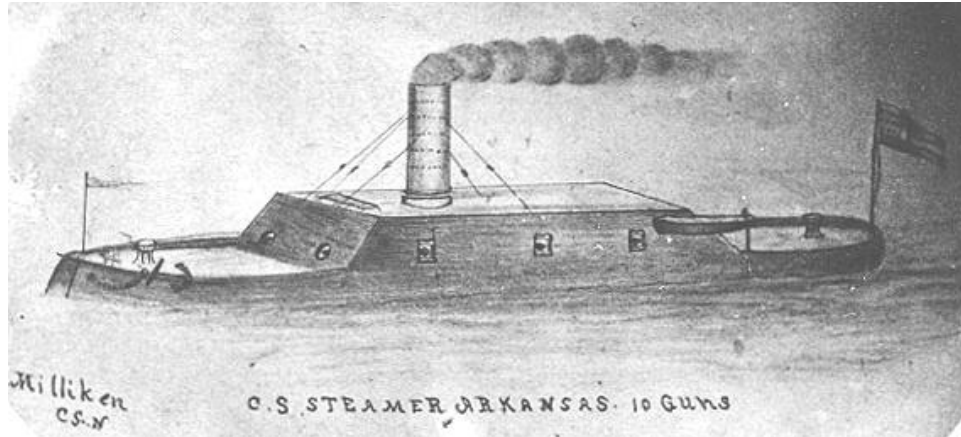

FIGURE VI.8. Contemporary sketch of *Arkansas* by Acting Master Samuel Milliken, CSN, who served onboard. (Online Library of Selected Images, Naval Historical Center, Department of the Navy, Washington, DC, 2012)

The Memphis ironclads were designed to carry 2 propellers, each 6 feet 9 inches in diameter and driven independently by 2 horizontal direct-acting non-condensing engines of 30-inch diameter and 24-inch stroke. Four high-pressure boilers with 4,000 square feet of heating surface were provided for powering the engines at a maximum pressure of 75 to 90 PSI and a maximum speed of 75 to 80 RPM. Improvements were made during construction to the power plant by adding two more boilers for a total of six. The engine stroke was also increased to 30 inches and the screw diameter to 8 feet. All of the machinery was produced by a local foundry of uncertain identity, possibly the Union Foundry & Machine Shop. (Holcombe 1993:39-40,57)

The engines of *Arkansas* were ultimately its greatest weakness despite the apparent superiority of such a purpose-built propulsion system and the advantages of independently-operating screws. Repeated breakdowns in the face of the enemy caused the ship to be destroyed by its crew. Unfortunately, no machinery plans are known to survive. Future archaeological survey of this famous ironclad's wreck near Baton Rouge, Louisiana, may reveal more details.

CSS Louisiana

This vessel was one of strongest and most powerful ironclads built by the Confederacy, but rendered a failure by its unique propulsion system. *Louisiana* had several features that should

have given good service for the protection of New Orleans in early 1862, but was ultimately hampered by lack of experienced workmen, materials, and suitable machinery. It was designed and built by E.C. Murray, an early proponent of ironclads and a veteran of 20 years' experience building sail and steam vessels. Murray's design called for an extremely simple and barge-like shallow-draft hull surmounted by a large armored casemate pierced originally for 22 guns, although only 16 were ultimately carried (Holcombe 1993:47).

Louisiana's final dimensions upon launching at Jefferson City, Louisiana, on 6 February 1862 were: 264 feet in overall length, 62 feet in beam, 6 feet in draft, and a displacement of 2,751 tons (Holcombe 1993:47). The massive ship's machinery arrangement was as unique as the rest of the design and appeared powerful on paper: two centerline paddlewheels and two smaller screw propellers under each quarter (Still 1994:53). The primary reason for this setup was protection from battle damage for the wheels, with the small screws to aid in maneuvering (Still 1994:97). No plans of *Louisiana* or its machinery layout are known to exist but a rough sketch of the ship's general layout gives a good idea of its appearance (Figure VI.9).

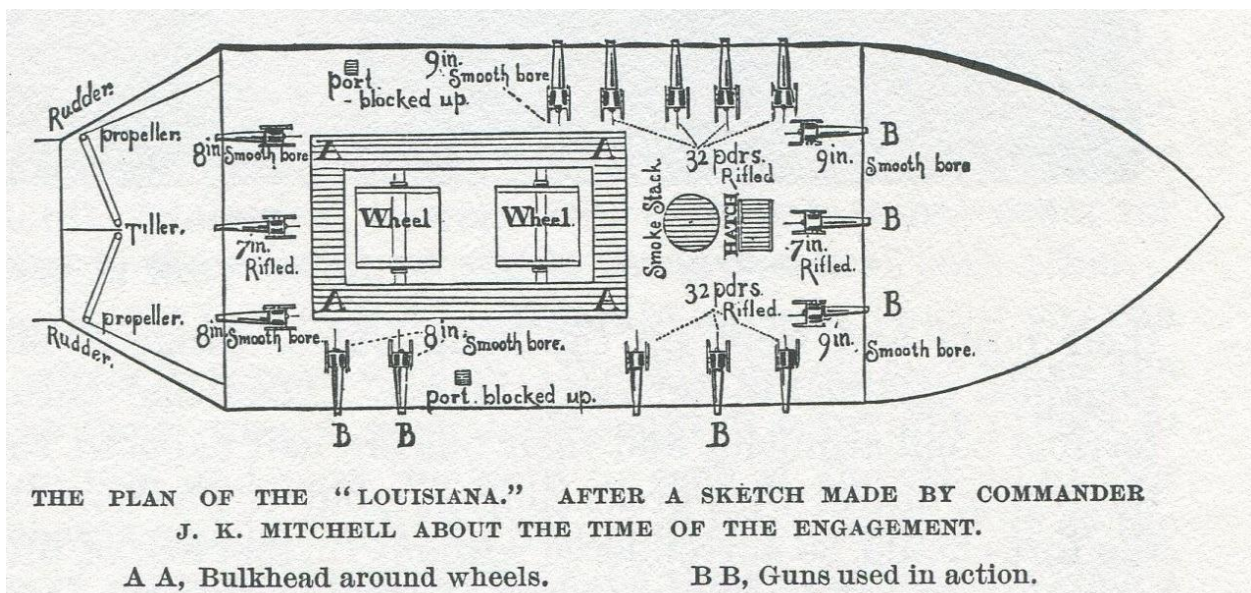

FIGURE VI.9. Rough plan of *Louisiana* based on a sketch by Commander J.K. Mitchell. (*Battles and Leaders of the Civil War* 1991 [Vol. 2, Part 1]:49)

Half of *Louisiana*'s machinery came from the large river steamer *Ingomar* which was purchased by Murray for that purpose. This vessel was a sidewheeler built at Louisville, Kentucky, in 1854. *Ingomar* displaced 730 tons at 275 feet in length, 40 feet in beam, and a draft of 7.5 feet. Its 2 inclined high-pressure engines each had a diameter of 28 inches with a 7-foot stroke (Way 1983:224). They were built by Roach & Long of Louisville (Confederate States of America [CSA] 1863: 378). On *Louisiana* each engine turned a 27-foot diameter, 19-foot wide paddlewheel (Holcombe 1993:48). The main paddle shafts were 24 feet long and 13 inches in diameter (CSA 1863:378). The other 2 engines, of unknown dimensions, were manufactured by Kirk & Co. of New Orleans to turn the small 4-foot diameter screws via wrought iron shafts 6.5 inches in diameter and 18-19 feet long (CSA 1863:372,378). They were not completely installed until immediately prior to the ship's destruction. Providing steam were six horizontal high-pressure boilers of unknown dimensions taken from *Ingomar* (Still 1994:53). Archaeological investigation of the wreck site in the Mississippi River may uncover more information.

CSS Georgia

Like *Louisiana*, *Georgia* (sometimes called *State of Georgia*) was a large early example of Confederate ironclad construction hampered by a faulty propulsion system. The ship ultimately served out its existence as a floating battery stationed near Fort Jackson below Savannah, Georgia, and was scuttled when that city was captured on 20 December 1864. Almost nothing is known of *Georgia*'s hull construction other than that it must have been simple—build time was only two months (Holcombe 1993:49-50). This ironclad floating battery remains today on the bottom of the Savannah River and archaeological surveys have been done, but nothing remains of the lower hull for a totally accurate reconstruction to be made (Panamerican Consultants, Inc. [PCI] and Tidewater Atlantic Research [TAR] 2007:65).

Georgia was designed by Savannah foundryman A.N. Miller to be a self-powered floating battery and was laid down sometime in March 1862, probably at Harding’s Shipyard adjacent to Miller’s foundry (PCI and TAR 2007:8). While information on *Georgia*’s dimensions exists, it is contradictory. Stated measurements vary from 150 feet in length and 50 feet in beam to 250 feet in length and 60 feet in beam (Holcombe 1993:50). Several contemporary drawings of uncertain accuracy depict the above-water portion of the ironclad and there appears to be a single weathered photograph still in existence (Figure VI.10) although its current location is unknown (PCI and TAR 2007:11). No plans of *Georgia* are known to survive.

Little information exists on the ship’s machinery other than that uncovered by archaeological surveys. All that was known prior was that *Georgia* was completed as a twin-screw vessel with “double engines” (PCI and TAR 2007:14). They were not able to move the vessel at any more than two knots even with the current, but did serve the important purpose of keeping the pumps running for combating numerous leaks caused by green wood (Still 1985:87).

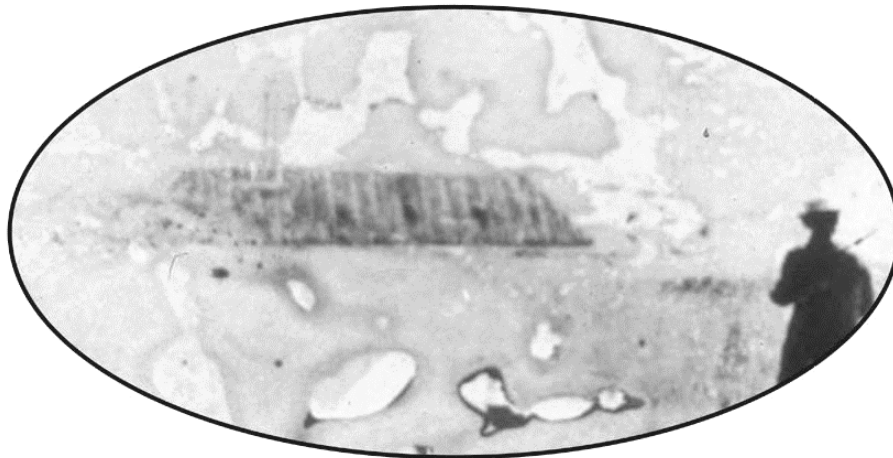

FIGURE VI.10. The only known photograph of what is thought to be *Georgia*. Spotted at a yard sale, a copy was furnished to the Coastal Heritage Society in Savannah. The current location of the original is unknown. (Panamerican Consultants, Inc. [PCI] and Tidewater Atlantic Research [TAR] 2007: Title Page)

The exact origin of *Georgia*’s machinery is not clear. It has been hypothesized that it was taken from another vessel but there is currently no proof of this. It also seems possible that the

machinery was manufactured by Miller's foundry since he designed and built the ironclad. It has been revealed that *Georgia's* steam machinery remains intact to some degree on the bottom of the Savannah River. During the course of archaeological investigations, elements of the engines, boiler(s), and propulsion were discovered and it is likely that more machinery is present but went undetected. All of the findings corroborate the description of a "double engine" given when the ironclad was afloat. It appears that *Georgia's* 2 engines were the single-cylinder horizontal direct-acting type, each with a diameter of 24 inches, a length of 39.5 inches, and a piston rod diameter of 3 inches. Figure VI.11 shows a reconstruction of the engine layout. In addition, a third cylinder was found which appears to have been a condenser (Figure VI.12). This piece of machinery measures 9 feet 4 inches in length and 20 inches in diameter, and has attached piping and valve components. (PCI and TAR 2007:42-44)

A number of disarticulated iron boiler plates, staves, rods, and firebricks were found in addition to the engine and condenser cylinders. The layout of these remains suggests a single rectangular boiler about 18 feet long, 7.5 feet in width, and very similar in design to the marine variant of locomotive boilers commonly used on small craft during the 19th century (Figure VI.13). It is unknown whether *Georgia* had more than one boiler. (PCI and TAR 2007:59)

One of the propellers and a portion of shafting were also found (Figure VI.14). The 3-bladed screw is 8 feet in diameter, with an 18-inch diameter hub and 12.5-foot long, 6-inch diameter shaft fragment attached. A stuffing gland and bearing are also present, denoting the point at which the shaft presumably passed through the hull (PCI and TAR 2007:61).

Georgia remains one of the most obscure Confederate ironclads despite its presence in the archaeological record. Studies on how to best save the remains from future dredging operations are ongoing.

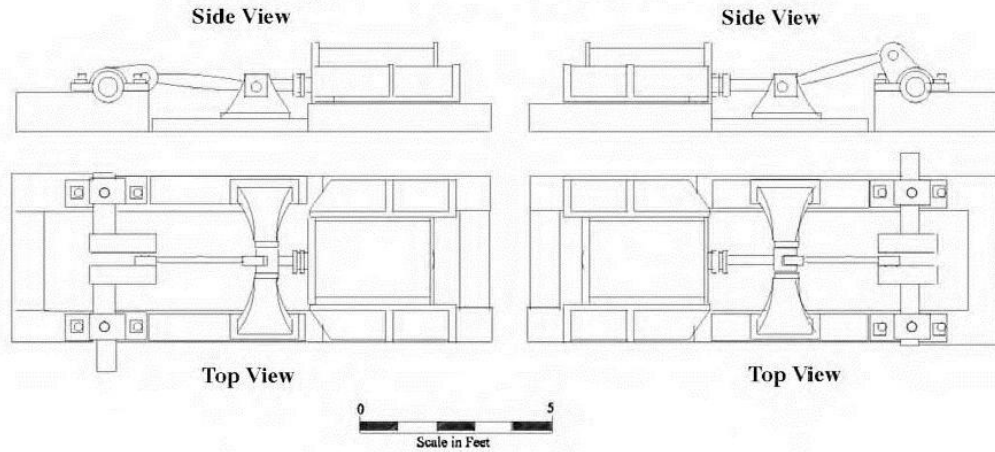

FIGURE VI.11. Reconstruction of *Georgia's* engines based on archaeological and historical data. They would likely have been placed in a staggered arrangement within the hull. (PCI and TAR 2007:63)

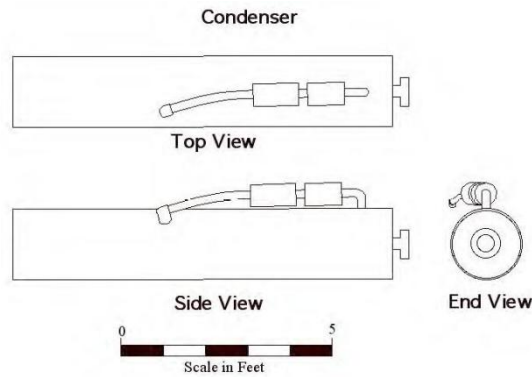

FIGURE VI.12. Reconstruction of steam condenser based on archaeological data (PCI and TAR 2007:64)

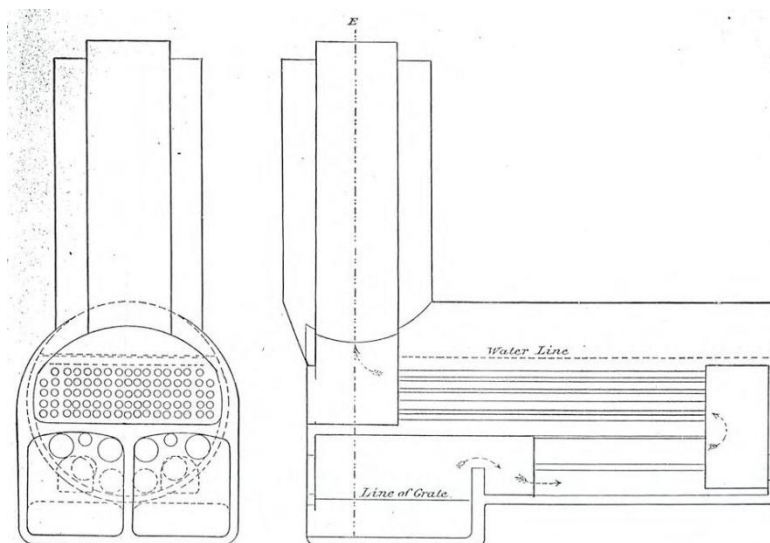

FIGURE VI.13. Typical mid-19th century horizontal marine firetube boiler, a variant of the common locomotive boiler type. (PCI and TAR 2007:60)

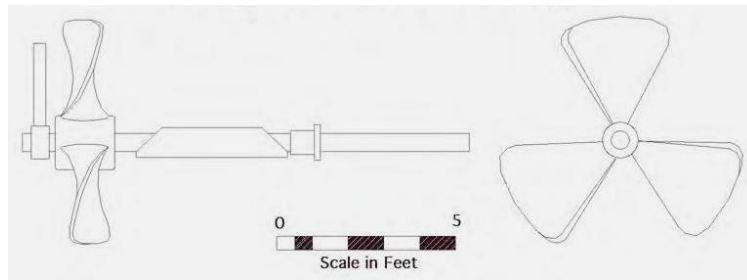

FIGURE VI.14. Reconstruction of one of *Georgia*'s propellers and shafting based on archaeological data. Note the sternpost attachment bracket, stuffing gland, and bearing. (PCI and TAR 2007:43)

CSS Richmond

The design of this ironclad was based largely off Naval Constructor Porter's proposed 1846 Pittsburgh model and ultimately became the most common among armored vessels in the Confederacy (Holcombe 1978:16-17). Current research indicates that over 20 vessels eventually incorporated *Richmond*'s design, although only 6 were ever finished and placed in service (Still 1985:94). *Richmond* was the first completed and naturally set the trend for all the following ships, although there were differences in what has been collectively designated the "*Richmond*-class" of Confederate ironclads.

Richmond itself conformed closely to Porter's original design with a length between perpendiculars of 150 feet, a beam of 34 feet, and a draft of 13 feet (Holcombe 1978:16). Overall length was approximately 174 feet, with a maximum beam over the ship's built-on armored knuckle of 44 feet (Peebles 1996:10). Figure VI.15 shows the original plans of a sister ship, *Savannah*. All the ships were armed with at least 4 guns and driven by a single 8 to 10-foot diameter screw. There was considerable difference in the steam machinery acquired for each vessel of the class.

Richmond was launched on 6 May 1862 at the Gosport (Norfolk) Navy Yard and finished at its namesake, the Confederate capital. The ship was powered by two horizontal low-pressure marine boilers built by either Tredegar Iron Works or the Shockoe Foundry (Confederate Naval

Works) in Richmond (*Official Records, Navies* 1987 [Ser. 1, Vol. 8]:68). Exact dimensions for *Richmond* are not known but the boilers probably conformed to the 10-foot length, 11-foot height, and 6-foot 9-inch diameter dimensions of the standardized type manufactured in Richmond and Columbus (Figure VI.16). The engine was obtained from the former Coast Survey ship-turned-lightship USS *Arctic* built at the Philadelphia Navy Yard in 1855 (Heyl [4] 1953:13). Nothing is known about the engine other than that it was probably a single-cylinder vertical inverted direct-acting type like that of most tugs and small screw steamers of the time. *Richmond* was consequently a slow and unwieldy vessel like many of its sisters. Archaeological surveys of the ship's remains in the James River may reveal more clues about its power plant.

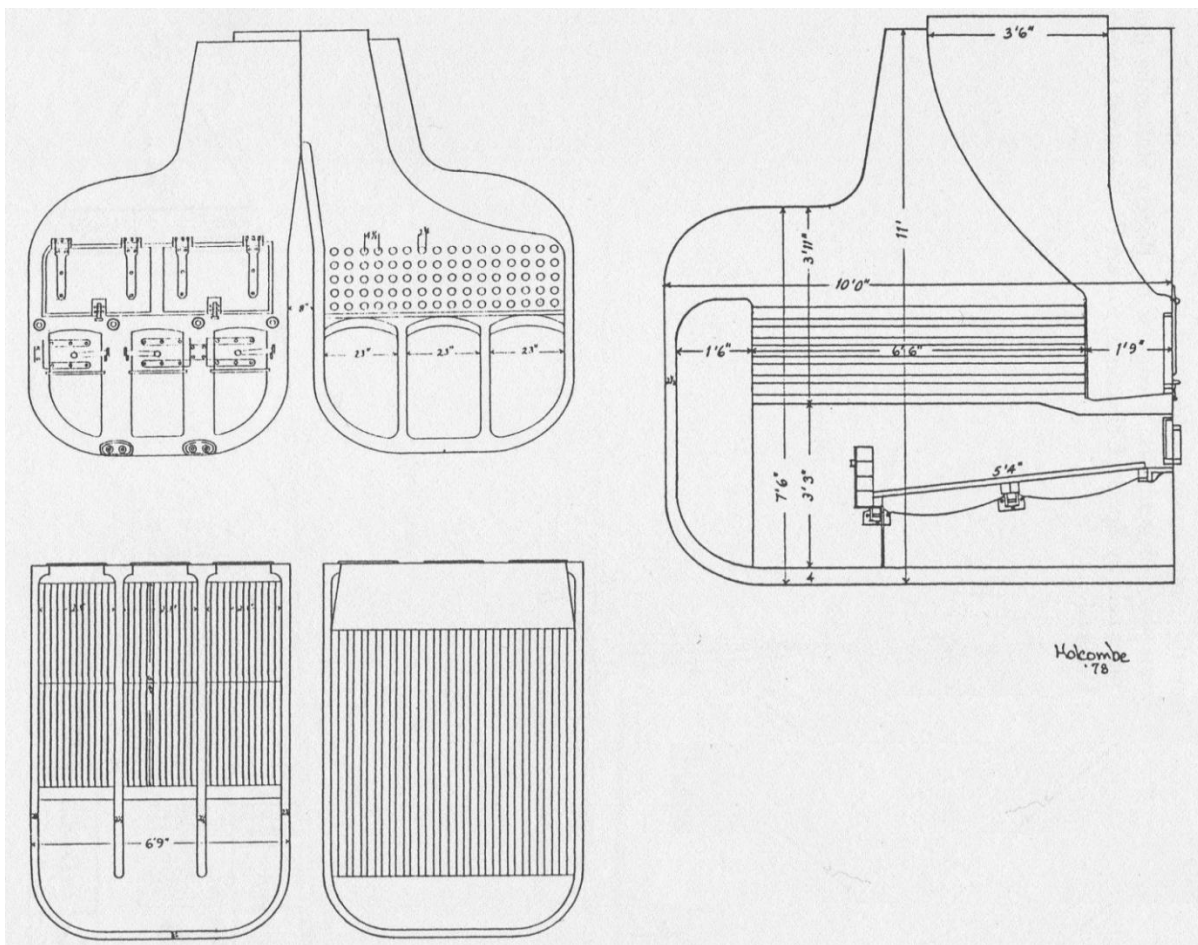

FIGURE VI.16. Plans of a pair of low-pressure horizontal “Scotch” marine boilers built at the Columbus Naval Iron Works, redrawn by Robert Holcombe in 1978. Boilers of this type were used in all the *Richmond*-class ironclads. (Courtesy of Robert Holcombe 2012)

CSS *Chicora*

Chicora was the second *Richmond*-class vessel launched, on 23 August 1862 at Charleston, South Carolina. It was one of very few Confederate ironclads to be photographed, as shown in Figure VI.17. *Chicora* was built by J.M. Eason & Brother, who also furnished the ironclad's two new boilers (of the same type as others in the class) and auxiliary machinery. The engine was salvaged from the 147-ton tugboat *Aid*, launched in August 1852 at Kensington, Pennsylvania. This small vessel, also known by the possible yard name *Concord*, was built by Theodore Bireay and measured 91 feet long, 22 feet wide, and 8 feet in draft. *Aid*'s engine was a single-cylinder vertical inverted direct-acting type measuring 30 inches in diameter and 28 inches in stroke. The piston rod measured 3.5 inches in diameter, while the crank shaft was 7.25 inches in diameter. (Mariners' Museum MS102 [Folder 4]:94)

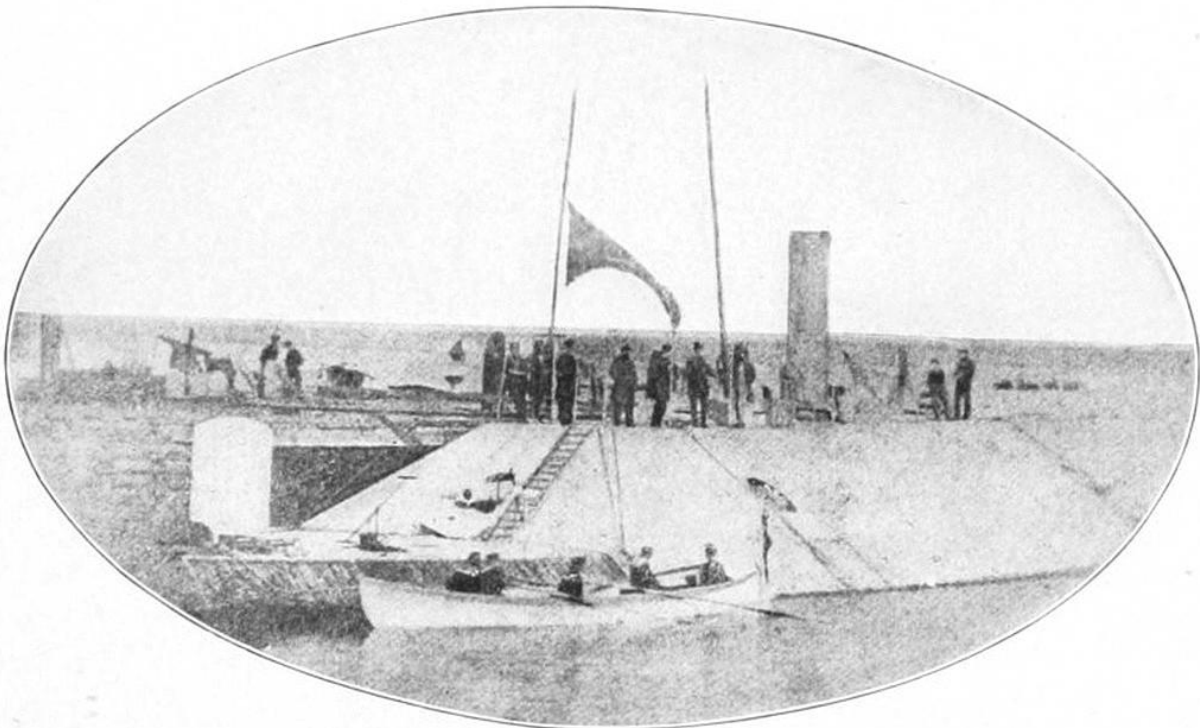

FIGURE VI.17. The only known photograph of a *Richmond*-class ironclad: CSS *Chicora* at its wharf in Charleston, circa 1863. Note the ship's hand-operated bilge pump on the after flush deck. (Miller 1911:239)

Reaney, Neafie & Co.'s Penn Works was the manufacturer of the engine as well as all other ironwork in the boat, including the single 2-furnace, 21-foot long, 7-foot 6-inch diameter return-flue boiler and single 4-bladed 8-foot diameter screw. Figure VI.18 shows a contemporary sketch. Materials from these latter components, especially the propeller and shafting, may have been reworked by *Chicora*'s builders for installation into the new ironclad. (Mariners' Museum MS102 [Folder 4]:94)

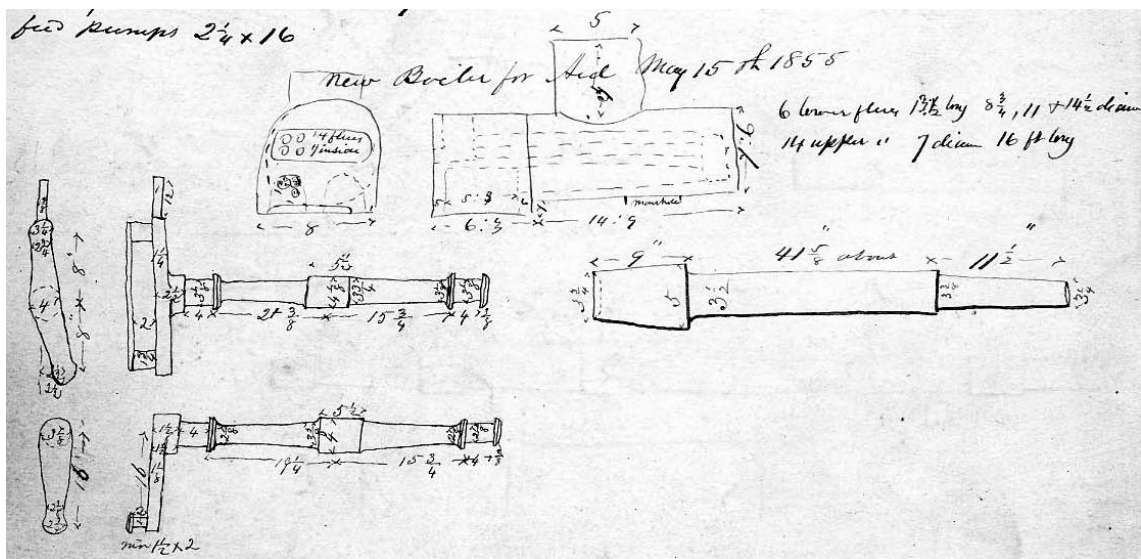

FIGURE VI.18. This sketch depicts a new boiler fitted to *Aid* in May 1855, as well as details of the reversing gear. This new boiler is of the same type as the one originally installed on the tug. Material from these components may have been reworked for *Chicora*. (Mariners' Museum MS102 [Folder 4]:94)

Surveys of the scuttled Charleston Squadron ironclads in July and August 1929 by the U.S. Army Corps of Engineers seem to corroborate the propulsion system details of *Chicora*. The wreck believed to be this ironclad had an engine measuring 30 inches in diameter with a 26-inch stroke, turning a 3-bladed 8-foot diameter propeller (Harris 2003:9). The slight difference in dimensions is probably the result of working underwater in a murky environment like Charleston Harbor. Figure VI.19 shows an archaeological example of a similar engine on the excavated wreck of a mid-1800s Savannah Harbor tug. Future surveys of the *Chicora* wreck site may uncover more details.

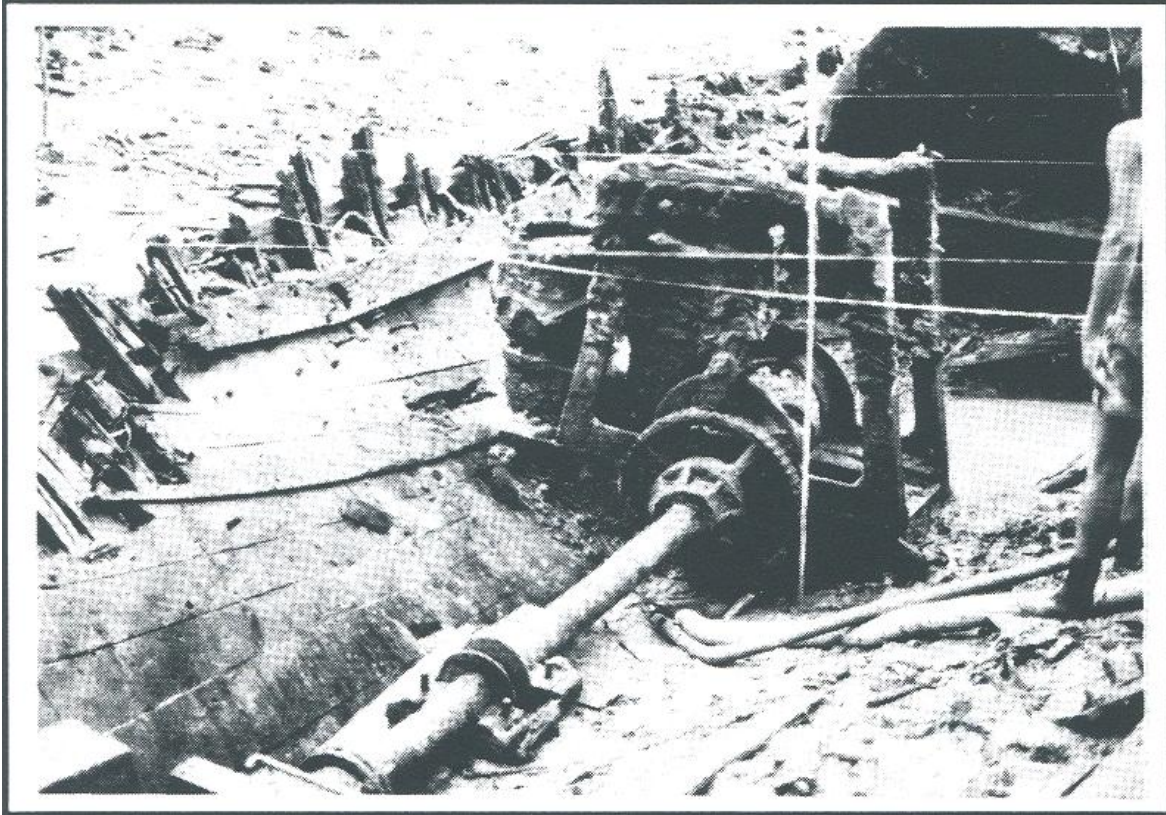

FIGURE VI.19. Partially-scavenged engine of a mid-19th century Savannah Harbor tugboat excavated archaeologically in 1992. *Chicora's* engine, taken from the tug *Aid*, would have been quite similar. This engine has had the steam cylinder removed, although the condenser can be seen at left. (U.S. Army Corps of Engineers 1992:50)

CSS Palmetto State

Palmetto State was Charleston's second ironclad. Although laid down before *Chicora* it was not launched until 11 October 1862 (Wexler 2008:43). *Palmetto State* conformed closely to the dimensions and tonnage of the other ships in its class but was completed with an octagonal casemate and pilot house placed abaft the stack, shown by a contemporary watercolor in Figure VI.20. The reason for these design changes is unclear (Holcombe 1993:67). The ironclad was built by James Marsh & Son at their Charleston shipyard with the foundry of Cameron & Co. (formerly the Phoenix Iron Works) building and supplying *Palmetto State's* boilers and auxiliary machinery (Wexler 2008:39). Presumably the ship's boilers were two of the same standardized kind fitted to the other *Richmond*-class vessels.

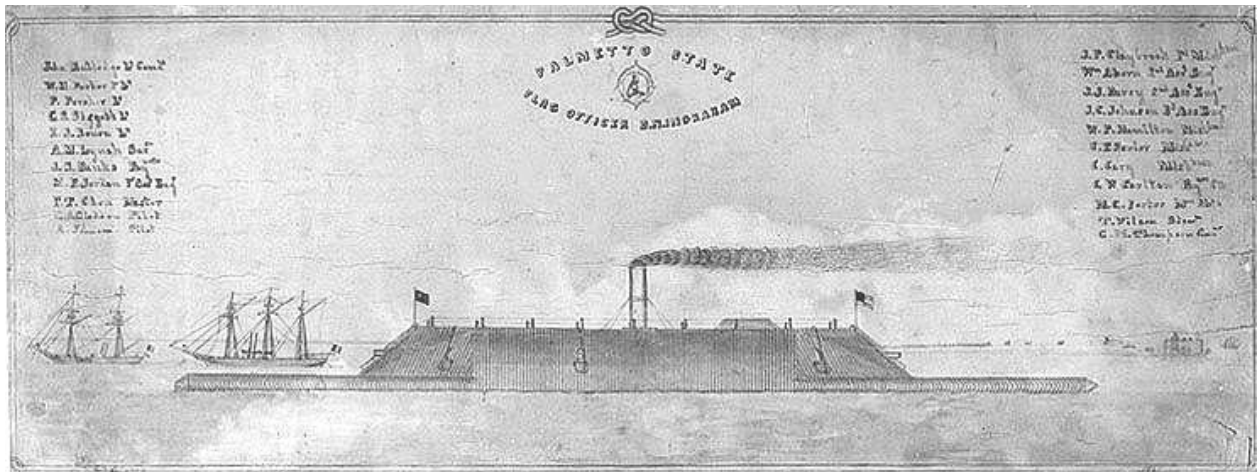

FIGURE VI.20. Contemporary watercolor of *Palmetto State* by Charles C. Cawson, circa 1862. (Online Library of Selected Images, Naval Historical Center, Department of the Navy, Washington, DC, 2012)

Like *Chicora*, *Palmetto State*'s engines were taken from another small ship. This was the South Carolina State Navy gunboat CSS *Lady Davis*, a single-screw iron-hulled tugboat (originally named *James Gray*) of 161 tons launched on 15 February 1857 at Philadelphia. This boat, also identified by the possible yard name *Tompkins*, measured 87 feet in length, 22 feet in beam, and 9 feet 5 inches in draft. The manufacturer of the hull and power plant was Reaney, Neafie & Co., Philadelphia's largest ship and engine builder. The engines were 2 single-cylinder horizontal direct-acting ones measuring 30 inches in diameter and 26 inches in stroke, with a piston rod diameter of 3.5 inches. Figure VI.21 shows a sketch of the machinery layout.

(Mariners' Museum MS102 [Folder 5]:211)

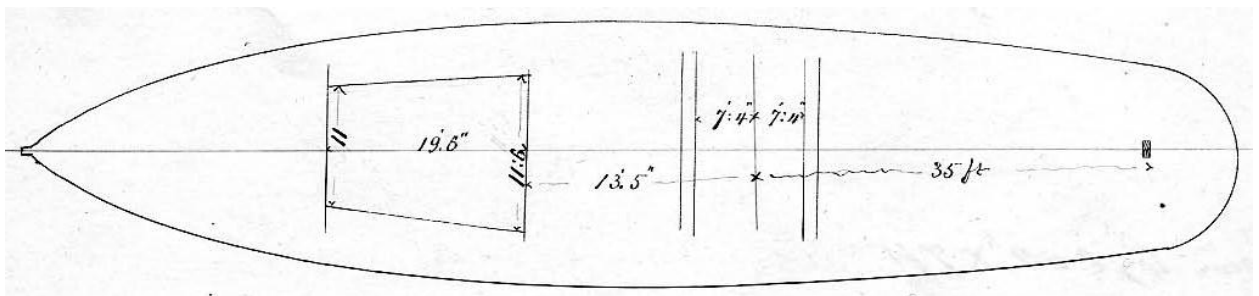

FIGURE VI.21. Sketch of general arrangement of *James Gray*'s hull and machinery, with the single boiler forward and twin horizontal engines placed 35 feet forward of the stern. (Mariners' Museum MS102 [Folder 5]:211)

It is also noted that *James Gray* was equipped with 2 force pumps 2.5 inches in diameter and 26 inches in stroke. Steam was supplied by a single cylindrical 2-furnace firetube boiler 18 feet long and 10 feet in diameter (Figure VI.22). Power was delivered to the engines at 30 PSI, which turned a 4-bladed, 8-foot diameter screw at 63 RPM. It is likely that some of these materials were adapted for use in *Palmetto State*. Future archaeological investigations of the ironclad's wreck in Charleston Harbor may reveal more information in this regard.

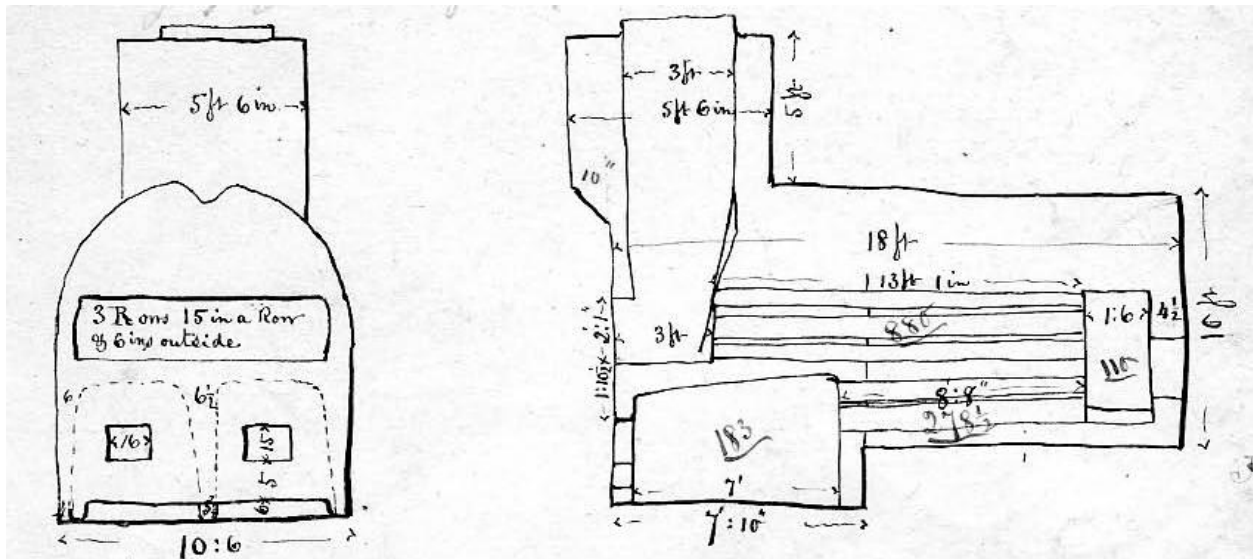

FIGURE VI.22. Sketch of low-pressure horizontal firetube boiler installed on *James Gray*. This layout was typical of 19th-century tugs, and some of its components may have been used in the construction of *Palmetto State*. (Mariners' Museum MS102 [Folder 5]:211)

CSS North Carolina

North Carolina was the first ironclad built for the defense of the Confederacy's most important blockade runner port, Wilmington. It is surprising to consider, therefore, that a vessel built for such an important station was destined to be the most decrepit *Richmond*-class ironclad commissioned (Holcombe 1978:17). The ship was built across the Cape Fear River from Wilmington on Eagles Island at the shipyard of Beery & Bros. and completed in June 1863 (Watts 1999:13). *North Carolina*'s layout was apparently quite similar to others of its class—archaeological surveys in 1993 and 1995 have contributed greatly to the scarce historical details

in this regard. Hart & Bailey Iron Works, Wilmington's largest foundry, also built and installed the boilers and auxiliary equipment (Watts 1999:12). Once again, it seems that the boilers of *North Carolina* were two of the standard type used in the other *Richmond*-class ships.

The primary reason for *North Carolina*'s unsatisfactory career was its secondhand engine, taken from the ex-Lake Erie tugboat *Uncle Ben*. This small 155-ton vessel was built in Buffalo, New York, in 1856 but had been captured and was serving as a Confederate gunboat at Wilmington (*Dictionary of American Naval Fighting Ships* 1963 [Vol. 2]:577). Nothing is known about its engine other than that it was too weak to propel *North Carolina* effectively (Watts 1999:13). It was probably the typical single-cylinder vertical inverted type commonly equipped to vessels like *Uncle Ben*.

North Carolina was used as a floating battery near Smithville, but the abundance of saltwater near the Cape Fear River's mouth allowed shipworms access to its unprotected bottom. The problem so badly deteriorated that eventually the pumps could not keep up and Wilmington's first ironclad sank in shallow water. Most of the armor was removed in 1864 and 1868. The ship's machinery was also salvaged at an unknown time and in 1871 the majority of the remains were destroyed by fire (Watts 1999:14). Only the very bottom of *North Carolina*'s hull is left as an archaeological site as seen in Figure VI.23.

CSS Raleigh

Raleigh was the second vessel to be built in Wilmington but was not constructed in the same yard as its sister *North Carolina*. These two ironclads could not have been more different despite being of the same class and built in the same city—*North Carolina* was a poorly-built and slow failure, while *Raleigh* turned out to be a fine example of a *Richmond*-class ironclad during its all-too-brief career. The ship was built at the shipyard of J.L. Cassidy & Sons at the

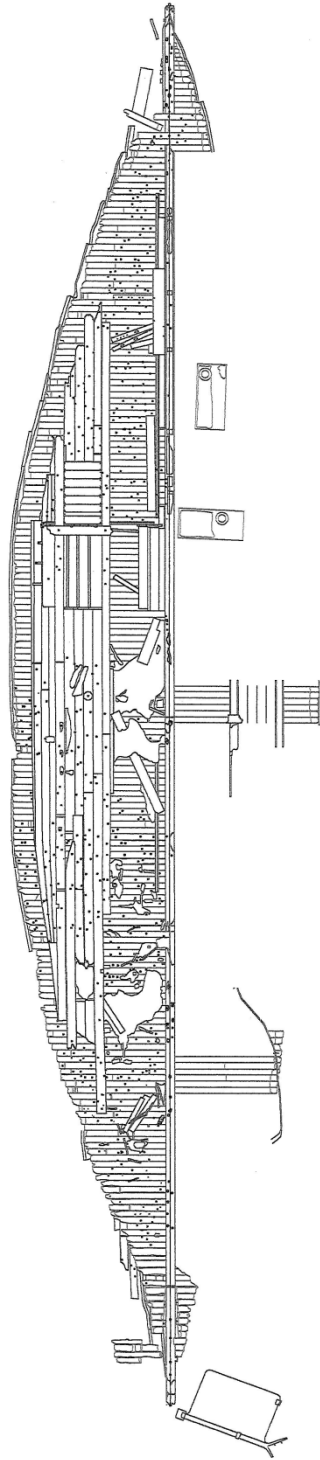

FIGURE VI.23. Archaeological site plan of the wreck of *North Carolina*, with bow at top. Only the flat portion of the hull below the turn of the bilge is preserved. No evidence of engine mounts survives; the only large iron artifact remaining is the rudder, at bottom. The two iron water tanks shown in the plan were destroyed between 1994 and 1999. The archaeological investigation only surveyed the starboard side. (Watts 1999:17)

foot of Church Street in Wilmington. Like *North Carolina* it closely followed in design and layout the other vessels of its class, but was apparently much better-built and had a lighter draft. In addition, greater trouble was gone to in order to find reliable motive power for *Raleigh*. The engines ultimately used were found to be the single-cylinder horizontal direct-acting type called for in the original plans. Figure VI.24 shows an engine room section through the wreck site. (Peebles 1996:35, 99-100)

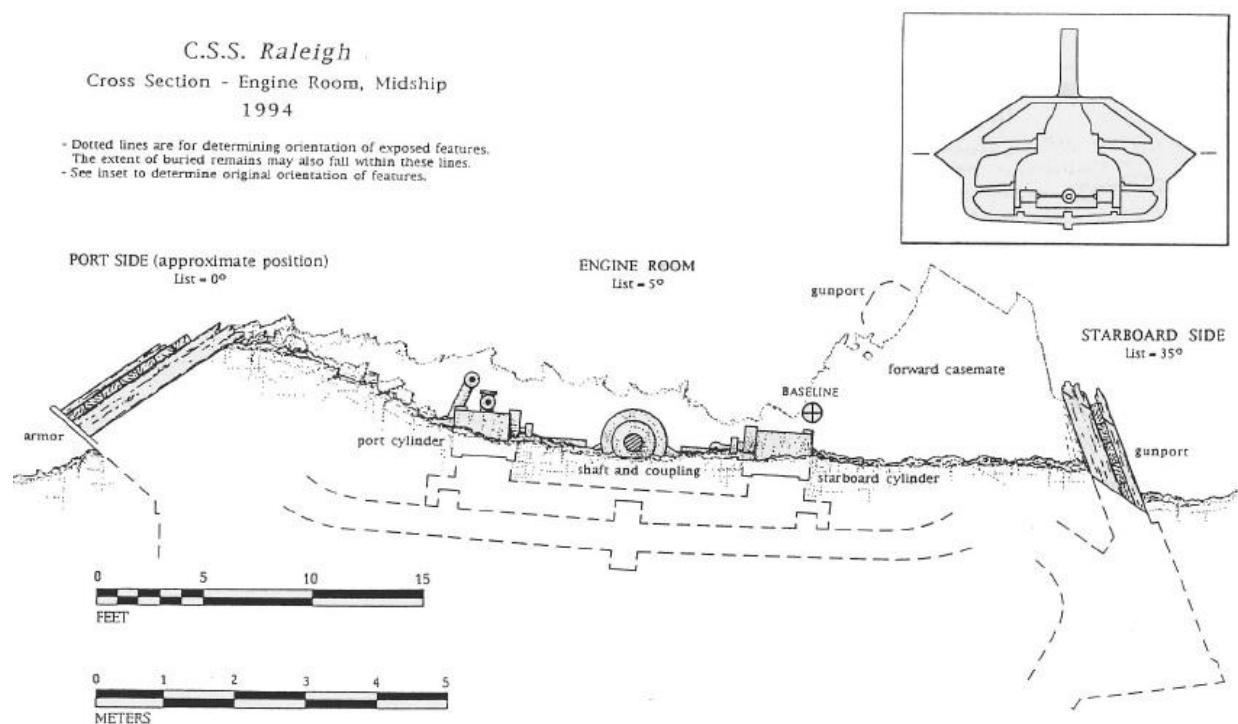

FIGURE VI.24. Archaeological section of the wreck of *Raleigh*, looking toward the bow. The survey only covered the starboard side but the engines (shown here), bits of the propeller shaft, rudder, and propeller were located and measured. (Peebles 1996:103)

Raleigh's two horizontal low-pressure boilers and auxiliary machinery appear to have been manufactured and installed by the Clarendon Iron Works of Wilmington (Combs 1996:63). The exact source of the steam engines remains unclear. Initial attempts to procure a power plant from the wrecked blockade runner *Modern Greece* failed, so new engines of the preferred horizontal type were sought (Peebles 1996:35). Those put in *Raleigh* appear to have been built in Richmond, but whether they were built specifically for the ironclad is still open for debate.

Fortunately, *Raleigh* is preserved in the archaeological record due to its accidental grounding in the Cape Fear River near Fort Fisher on 7 May 1864. Investigations in 1993 and 1994 revealed that its engines remain. They measure 24 inches in diameter with a 3-foot stroke. Each cylinder had a three-foot square built-in valve chamber and rested on concrete blocks instead of more usual wood ones. Piston rod diameter was 3 inches and connecting rod diameter 4 inches, while propeller shaft diameter was 9 inches. Future investigations of the well-preserved wreck may finally uncover information on the true source of the engines.

CSS *Savannah*

The last example of a *Richmond*-class ironclad to be completed was constructed in the important port of Savannah, Georgia, and named for that city. *Savannah* was built at the shipyard of H.F. Willink and closely followed all its sister ships in design and layout. It was launched on 4 February 1863, and the Columbus Naval Iron Works manufactured the engines and boilers (Holcombe 1978:18). These conformed to the other vessels of the class in layout, but much more information exists concerning *Savannah*'s power plant because of the fortunate survival of its engineering plans in the collections of the Port Columbus Civil War Naval Museum. These plans offer a nearly-complete look at the ironclad's layout (Figures VI.25 and VI.26).

Records indicate that *Savannah*'s engines were originally intended for a 150-foot gunboat built at Milton, Florida, but when that project was cancelled Secretary Mallory ordered them transferred to the ironclad then building in Georgia (National Archives RG 45 [Area 8 File]: Frame 0258). Measurements taken from the surviving engineering drawings show that *Savannah*'s 2 horizontal single-cylinder direct-acting engines were 28 inches in bore diameter (34.5 inches in external cylinder diameter) with a 20-inch stroke. Unlike the purpose-built engines of *Raleigh*, which were also probably obtained from an unfinished wooden gunboat,

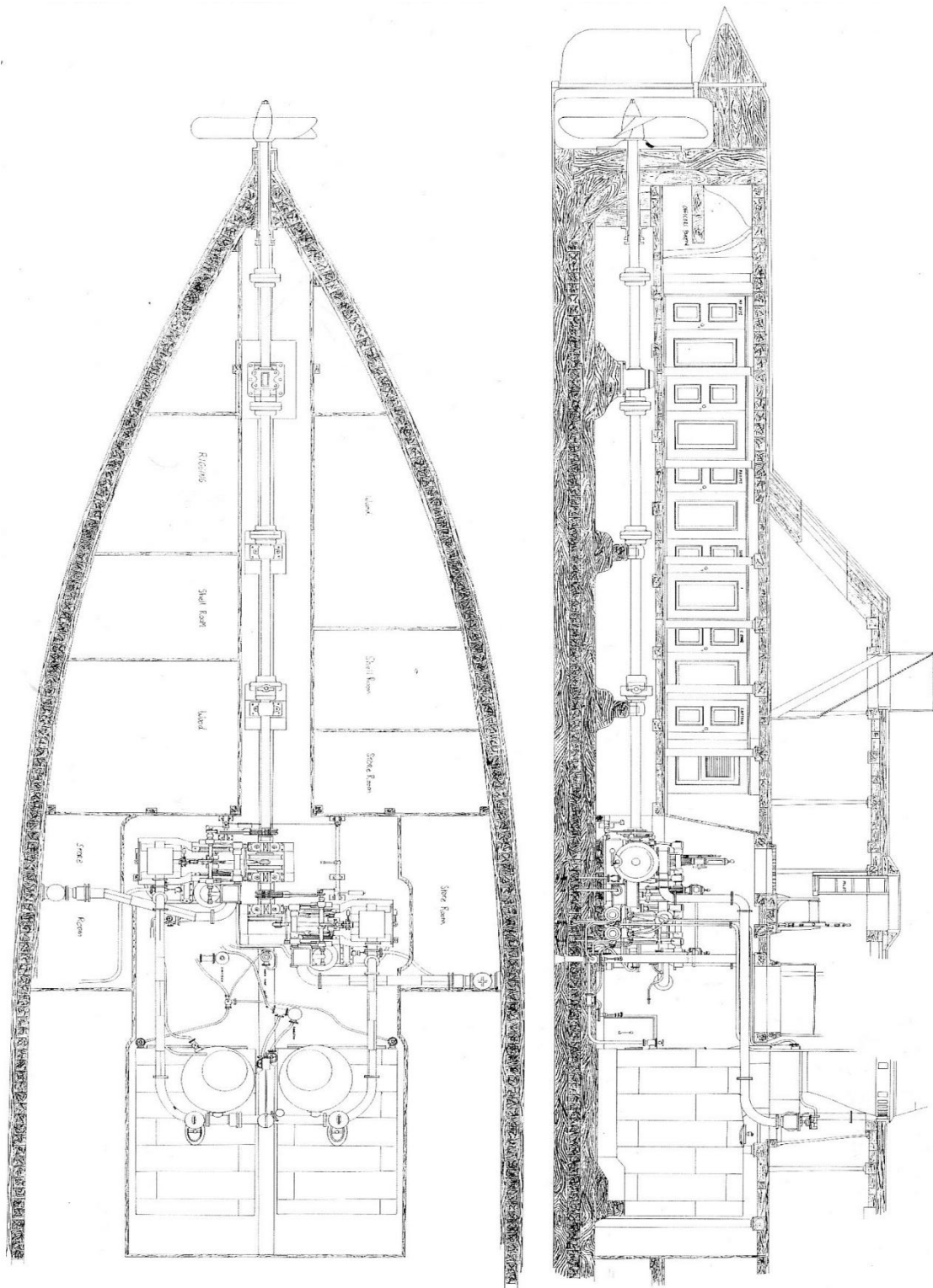

FIGURE VI.25. Plans of inboard profile of *Savannah* showing machinery configuration and layout, redrawn by Robert Holcombe. Note the location of the pilot's hatch directly over the engine room and behind the stack, possibly offering greater ease of communication during battle maneuvers. (Courtesy of Robert Holcombe 2012)

Savannah's valve chambers were on top of the cylinders. It appears that reverse motion was accomplished by the tried-and-true Stephenson's valve gear. The propeller shaft was 50.3 feet long, 8 inches in diameter, and manufactured in 5 sections. *Savannah*'s 2 boilers were of the preferred horizontal firetube type installed on others of its class. They measured 7 feet 10 inches in diameter, 11 feet 2 inches in length, and 12 feet in height.

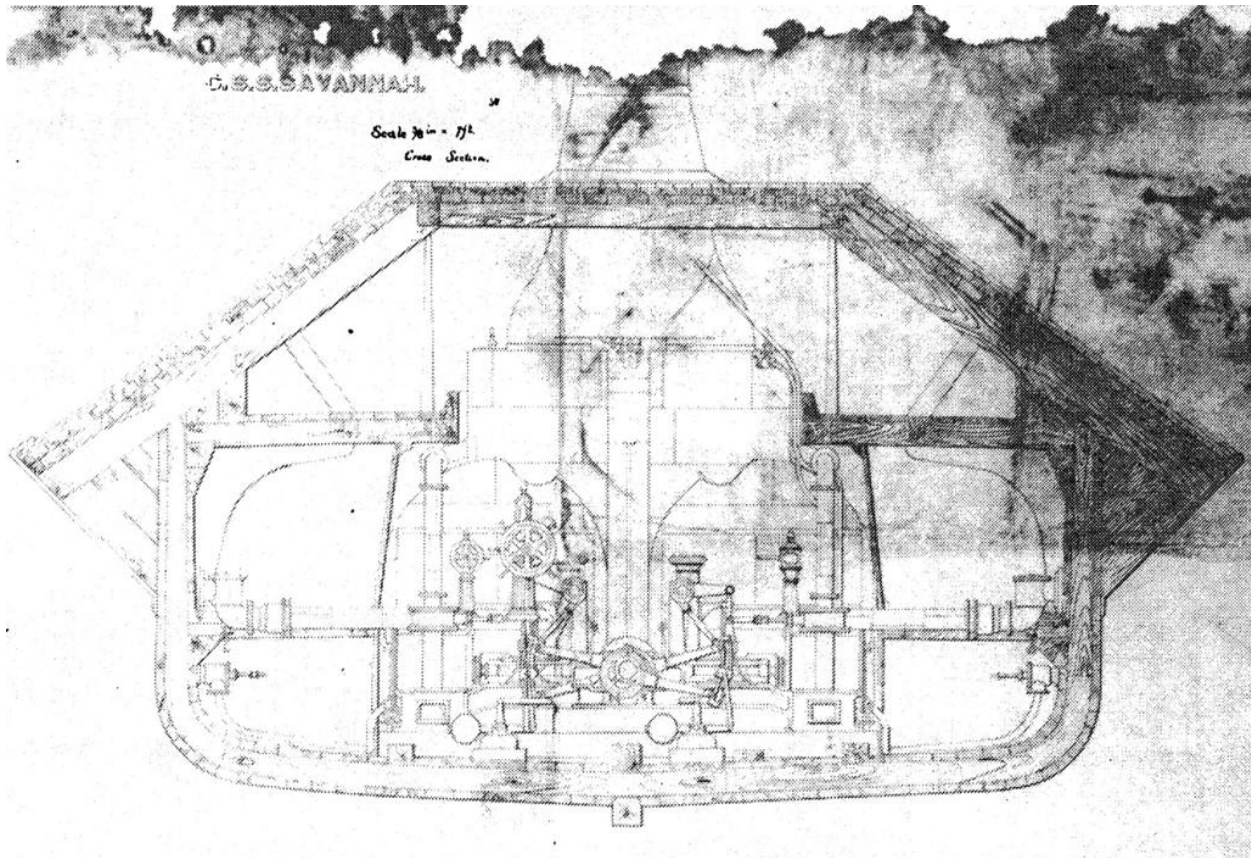

FIGURE VI.26. Plans of engine room cross-section of *Savannah*. The connecting rods, eccentrics, and links for the reversing gear can be seen on the propeller shaft. Note the engineer's platform with throttle wheel and other controls at berth deck level on the left. (Still 1985:103)

It is fortunate that *Savannah*'s detailed machinery plans survive, because although the ironclad was scuttled in December 1864 and survives in the archaeological record, it was heavily salvaged in the 1890s. In those operations, the ship's boilers and machinery were removed (Judy Wood 2011, elec. comm.). There appears to be little left at the wreck site, but future archaeological investigations are needed to verify its overall layout and condition.

CSS *Tennessee*

Tennessee was built by Henry D. Bassett at Selma and finished in Mobile, Alabama. It was another Confederate ironclad forced to rely on secondhand machinery. This powerful ship was launched on 28 February 1863 but not finished until a year later due to shortages of men, materials, and modifications made during construction (Still 1985:192,195). As completed, *Tennessee* differed from the original design in having a shorter octagonal casemate with six guns. Dimensions were 217 feet in overall length, 209 feet length on deck, 48 feet in beam, and an average draft of 14 feet (Holcombe 1993:71-72; *Official Records, Navies* 1987 [Ser. 1, Vol. 21]:547). Fortunately, several photographs exist of *Tennessee* after its capture by the U.S. Navy in August 1864 (Figure VI.27).

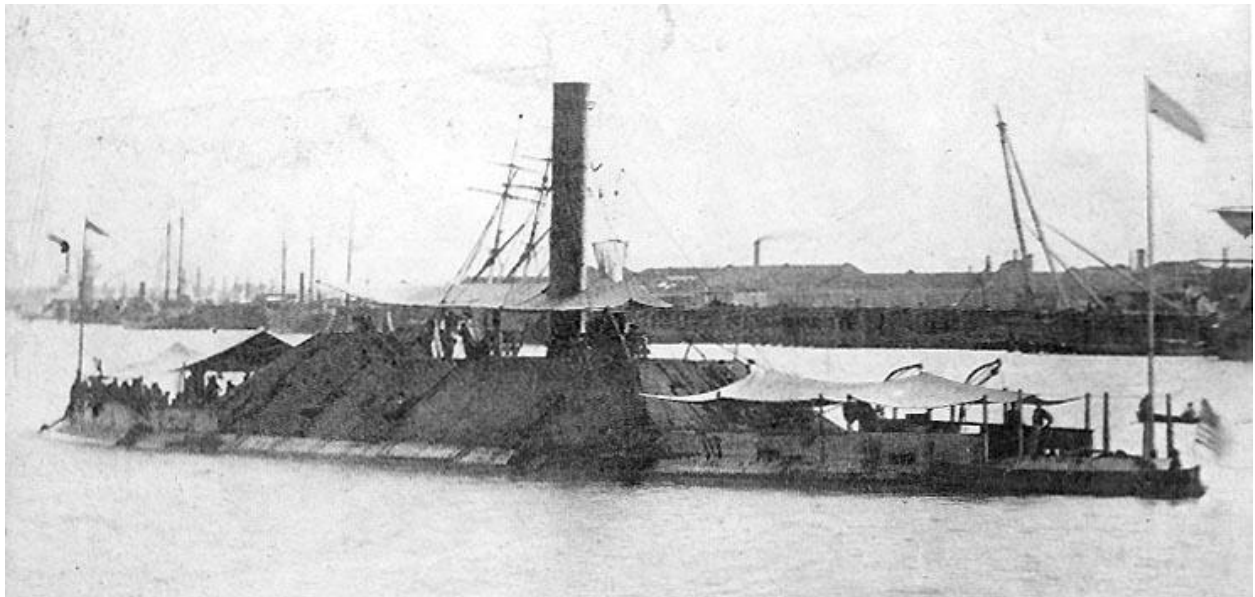

FIGURE VI.27. Circa 1865 photograph of *Tennessee* off New Orleans after its capture and induction into the U.S. Navy. (Online Library of Selected Images, Naval Historical Center, Department of the Navy, Washington, DC, 2012)

At the time of *Tennessee*'s construction no adequate engines could be built, so salvaged machinery was instead substituted (Still 1985:191). It has been widely stated, presumably beginning with the Union survey report, that this machinery came from the river steamer *Alonzo*

Child. The dimensions of that vessel's engines do not match those of *Tennessee*, nor does the time of their removal fit with time of installation on the ironclad (Still 1985:191-192). As previously discussed, it appears instead that the engines came from the river steamer *Vicksburg*. This vessel was a 635-ton sidewheeler 244.5 feet in length and 36 feet in beam with a draft of 7.5 feet built at New Albany, Indiana, in 1857 (Way 1983:468). It was powered by 5 boilers and two 24-inch diameter engines with a 7-foot stroke. These numbers fit with those given in the survey report of *Tennessee* (*Official Records, Navies* 1987 [Ser. 1, Vol. 21]:548-549).

The official report on *Tennessee* described the engines as being the typical single-cylinder non-condensing riverboat type with poppet valves, placed fore and aft in the ship. In order to make them effectively turn *Tennessee*'s single 12-foot diameter screw they were "...geared to an idler shaft by spur gearing with wooden teeth, and from the idler shaft to the propeller shaft by bevel cast-iron gear". This interesting and surprisingly reliable arrangement is shown in Figure VI.28.

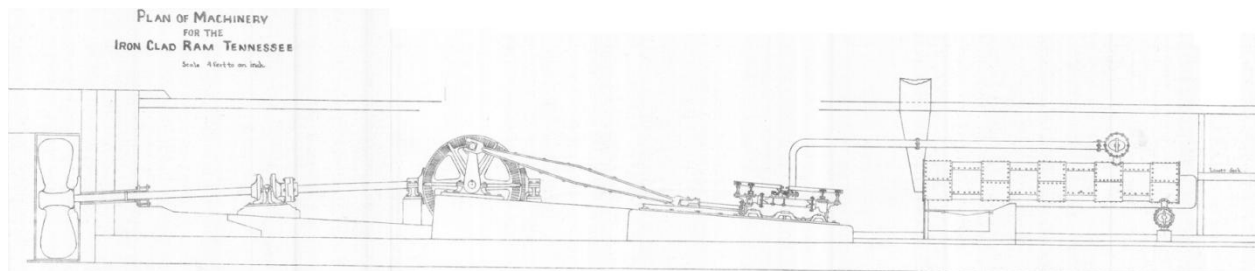

FIGURE VI.28. Plans of *Tennessee*'s improvised propulsion system, redrawn by Robert Holcombe in 1982. The original was donated to the Port Columbus Civil War Naval Museum by descendants of Samuel J. Whiteside, a civilian engineer who was involved in the installation of the machinery. Note the large wooden gear wheels used to connect the horizontal paddlewheel engines to the single propeller shaft. (Courtesy of Robert Holcombe 2012)

The ship's 4 boilers were of the horizontal flue type and 24 feet long with a single furnace under all of them (*Official Records, Navies* 1987 [Ser. 1, Vol. 21]:548-549). *Tennessee* was also unusual among Confederate ironclads in that it was fitted with a mechanical blower (or forced-draft fan) to assist in drawing the fires for better steaming. The only other Southern

ironclads so equipped were CSS *Atlanta* and *Missouri* (Still 1985:101). Nothing remains of *Tennessee* in the archaeological record, for following its U.S. Navy service the famous vessel was sold for scrap on 27 November 1867 (*Dictionary of American Naval Fighting Ships* 1963 [Vol. 2]:574).

CSS Columbia

Columbia was the much-modified sister ship of *Tennessee* and was one of the most powerful vessels commissioned by the Confederates, with an armament of four pivot and two broadside guns (Holcombe 1993:74). This ironclad was built by Francis M. Jones at Charleston—laid down in December 1862 and launched on 10 March 1864 (Holcombe 1993:72,88). *Columbia* was modified in the course of construction to a refined knuckle shape: instead of sloping back from the waterline to main deck level as on other ironclads, the new design continued to flare up to main deck level (Figure VI.29).

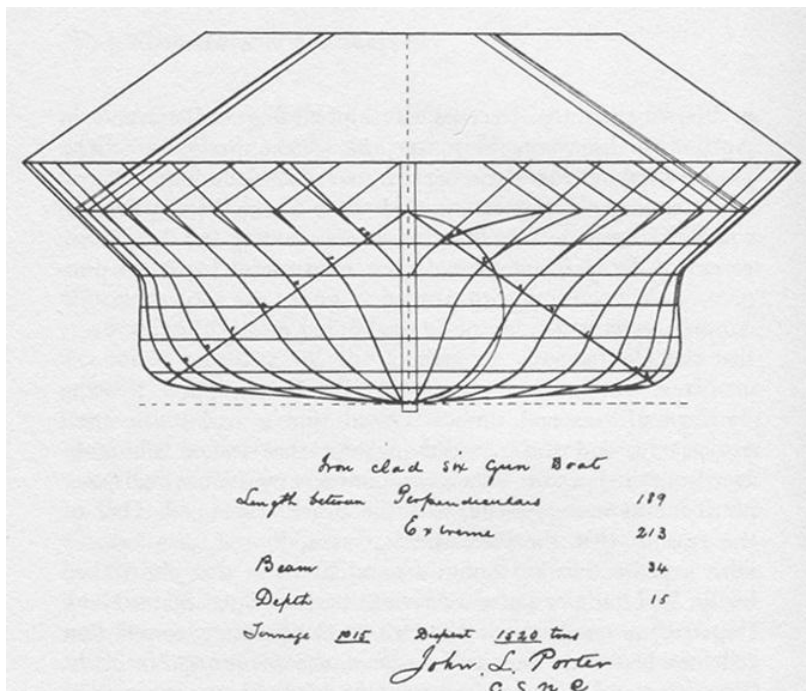

FIGURE VI.29. Lines of CSS *Columbia*, “Iron clad six gun boat, Length between Perpendiculars 189 [feet], Extreme 213, Beam 34, Draft 15, Tonnage 1015, Dispcmt [displacement] 1520 tons, John L. Porter, C.S.N.C.” Note the improved casemate and knuckle layout superimposed over the old design. (Still 1987:60)

This improved layout increased seaworthiness and gundeck room, allowing more pivot guns to be carried (Holcombe 1993:74). *Columbia* was also originally designed to be driven by 2 propellers (Figure VI.30) but was finished with a single 3-bladed screw 10 feet 8 inches in diameter turning on an 8-inch diameter shaft (*Official Records, Navies* 1987 [Ser. 2, Vol. 1]:251). All of these design changes resulted in an ironclad 215.78 feet in length and 48.5 feet in beam, with a draft of 13.5 feet (Holcombe 1993:73). Figure VI.31 shows the inboard profile.

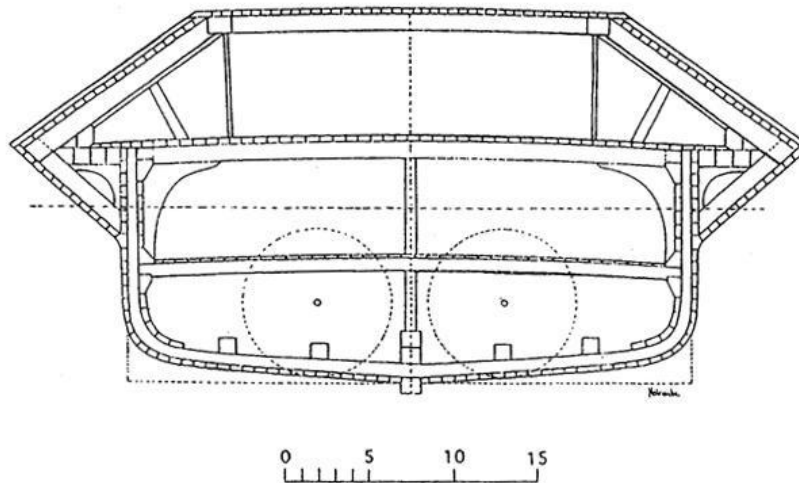

FIGURE VI.30. *Columbia*'s original layout with two propellers. (Holcombe 1993:74)

Columbia's power plant was brand new and manufactured specifically for the ship by the Columbus Naval Iron Works (Turner 1999:158). Five 5-flued horizontal boilers 22 feet long and 4 feet wide, for a total grate area of 129 square feet, with a lower flue diameter of 12 inches and an upper one of 10.5 inches powered 2 non-condensing horizontal single-cylinder engines of 36-inch diameter and 24-inch stroke (*Official Records, Navies* 1987 [Ser. 2, Vol. 1]:251). *Columbia* was never effectively tested in Confederate service, for just days after commissioning in January 1865 the ship ran hard aground on a sunken wreck in Charleston Harbor. The ship seemed to severely crack its keel and was abandoned. Later, the Union surveyed and salvaged the powerful ironclad in April 1865, after which *Columbia* was taken to Norfolk (*Dictionary of American Naval Fighting Ships* 1963 [Vol. 2]:510). It was laid up and later scrapped.

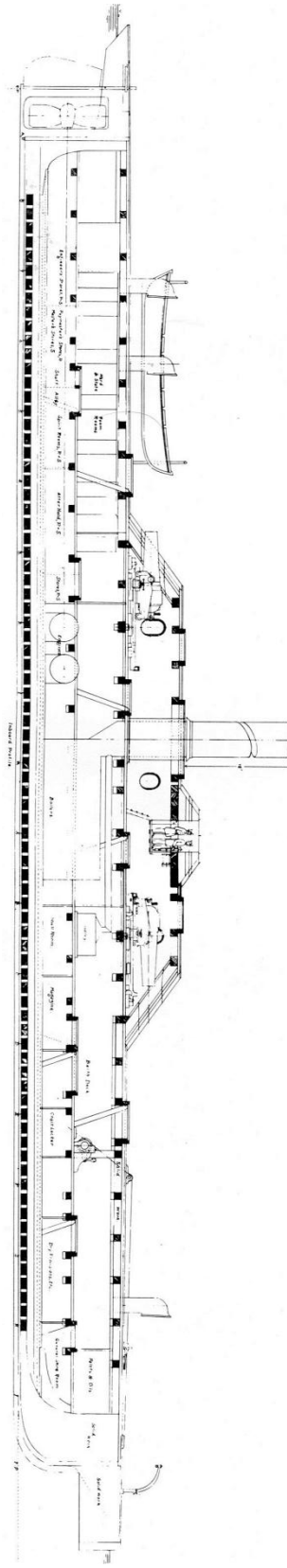

FIGURE VI.31. Inboard profile of *Columbia*, showing machinery layout. (Coker 1987:233)

CSS *Charleston*

Very little is known about the machinery of the third ironclad to be constructed in Charleston. *Charleston* was built by the firm of J.M. Eason & Brother, who began construction in December 1862 (Wexler 2008:64). The design of this ironclad is attributed to Acting Naval Constructor William A. Graves and is notable chiefly for its flat floors and soft bilge turns compared to Porter's designs as well as an unusually long protruding ram. Figure VI.32 shows plans of the original design of *Charleston*, although during construction the ship was modified to carry two pilothouses (one forward and one aft) and the casemate was changed to the simpler four-sided layout. In addition, the upper bow was modified for carrying a spar torpedo. The end product of all this was a large ironclad measuring 180 feet between perpendiculars, 201 feet overall, 44 feet in extreme beam, 14 feet in depth of hold, and a little over 12 feet in draft (Holcombe 1993:77-79).

Charleston was apparently finished in early 1863 and commissioned on 19 August of that year. The ship was driven by a single nine-foot diameter screw powered by one or two direct-acting low-pressure engines which pushed *Charleston* along at approximately six miles per hour. The number and type of boilers are unknown. All of the existing information presented here comes from an August 1863 entry in the John Horry Dent Papers, a restricted collection kept by the University of Alabama. No other information on *Charleston*'s machinery or its source has been found. It is likely that the ship's builder, the Eason foundry, manufactured it. *Charleston* was blown up along with the other Charleston Squadron ironclads to prevent capture in February 1865. Like those vessels, it lies in shallow but dark, polluted, and heavily traveled waters. Future dedicated archaeological investigation of the wreck site in this difficult environment may uncover more details.

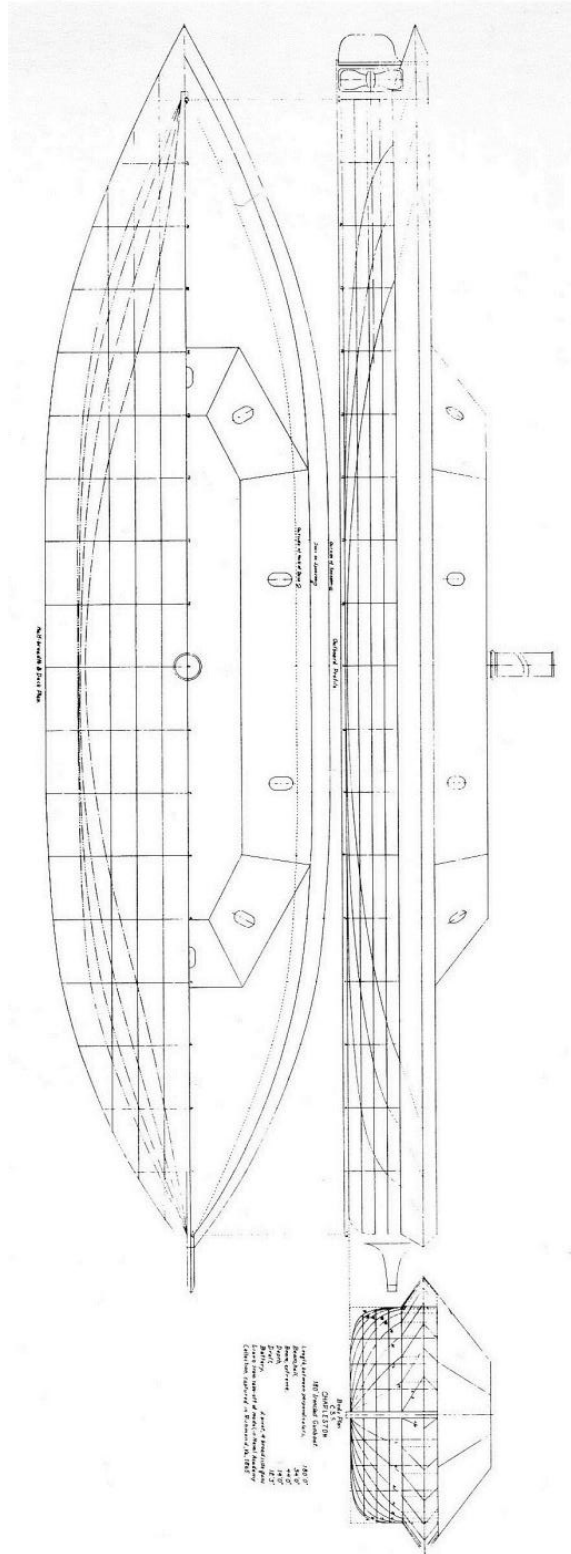

FIGURE VI.32. Plans of *Charleston*, drawn from a half-model located at the Navy Department in Richmond, 1865. The model is one of two located in the U.S. Naval Academy Collection at the Smithsonian Institution. (Coker 1987:230)

CSS Virginia II

The second Confederate ironclad named *Virginia* was quite similar to *Charleston* as originally designed by Graves. Due to wartime experience and delays in construction, the final product ended up being quite different and resulted in the most powerful ironclad commissioned by the Confederacy. *Virginia II* was modified to carry a shorter, stronger octagonal casemate for four guns and additional armor—six inches in thickness on the sides and eight on the ends. In addition, cambered and sloped flush decks just forward and aft of the casemate were installed. These provided more ablative and angled armored surfaces for projectiles to glance off. Fortunately, all these design changes can be seen in the surviving blueprint drawings of the ship as shown in Figure VI.33. (Holcombe 1993:81)

Virginia II was built at the site commonly referred to as “Graves’s Yard” directly across the James River from the more prominent Rocketts yard east of downtown Richmond (Coski 2005:237). William Graves, the ship’s designer, had direct control over its construction from keel laying to launch on 29 June 1863 (Coski 2005:86). *Virginia II* differed slightly from *Charleston* in measurements: 203 feet long overall, 48.5 feet in beam, and a 14-foot draft (Holcombe 1993:90). Its general hull form remained the same.

There is some uncertainty about the provenance and final layout of *Virginia II*’s power plant. Several records suggest that the ironclad’s machinery was built new either at Tredegar Iron Works or the Shockoe Foundry (Confederate Naval Works) just a few miles away from the shipyard (Coski 2005:72). The most prominent of these sources are *Official Records, Navies* (1987 [Ser. 2, Vol. 2]:269), and Dew (1987:122,265). The *Virginia II* plans also appear to show 2 single-cylinder horizontal direct-acting engines approximately 40 inches in diameter and 38 inches in stroke that were of the typical design manufactured for several ironclads. Overhead

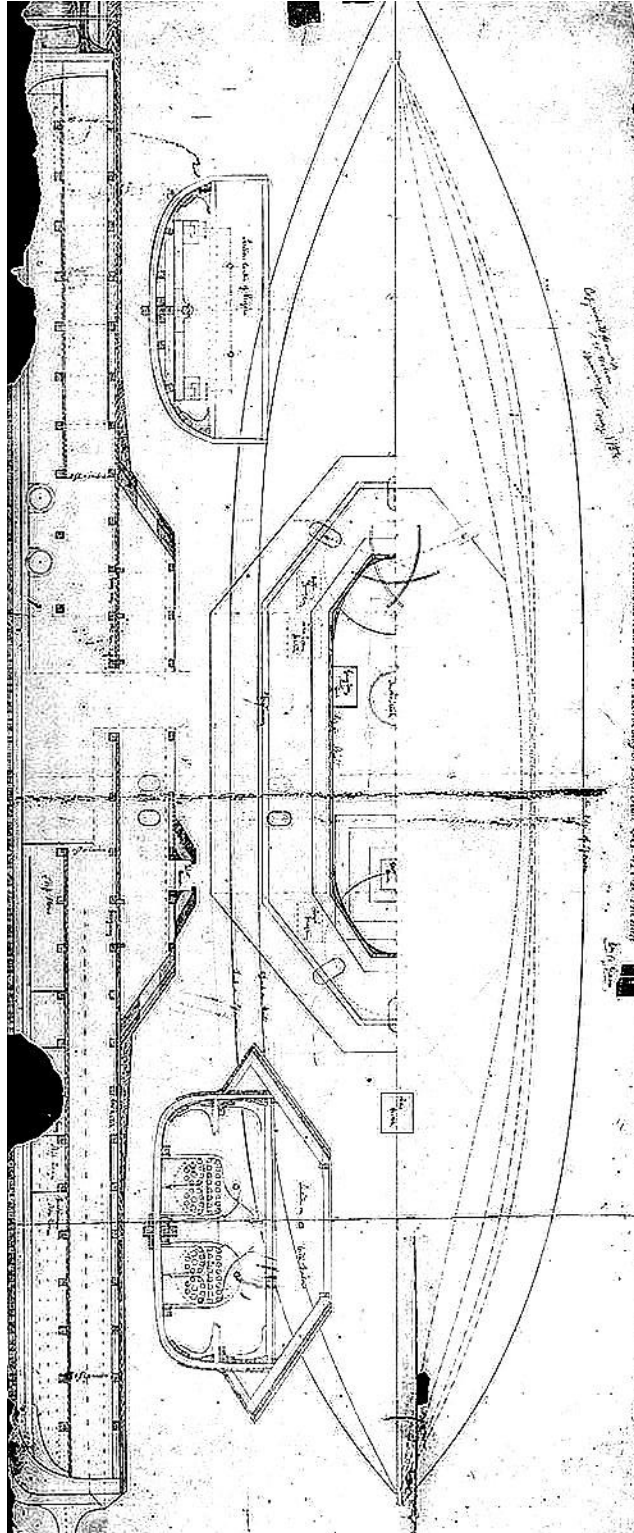

FIGURE VI.33. 1863 plans of *Virginia II*, showing machinery layout in addition to hull construction. It is not known if this view represents final configuration of the engines. Several other details are unclear. Fortunately, the boilers are shown much more clearly. (Online Library of Selected Images, Naval Historical Center, Department of the Navy, Washington, DC, 2012)

valve chests like those on *Raleigh*'s engines can be seen as well. Despite all this evidence, a 25 April 1865 survey report made by Commander William Radford, USN, of the captured Confederate Naval Works lists "One pair of double engines, 30" cylinder and 28" stroke, high pressure and similar to those used on Ram Virginia [II]" (National Archives RG 45 [PN File]: Roll 42). "Double engine" in 19th-century parlance generally meant a two-cylinder engine, lending credence to reports of *Virginia II* carrying British engines (Still 1994:67). British and Scottish manufacturers were the world leaders in iron construction for both hulls and engines by the 1860s. Twin-cylinder engines were successfully employed by them long before the type was common in the United States.

According to the surviving plans of *Virginia II* and assuming they can be trusted in regards to boiler if not engine layout, the ship was powered by 2 horizontal boilers with 2 furnaces each. The boilers were 22 feet long, 8 feet in diameter, and 9 feet high. Propulsion was provided by a single 10-foot diameter screw turning at the end of a 54-foot long, 11-inch diameter shaft.

Virginia II still exists as an archaeological resource in the James River near Drewry's Bluff due its destruction on the night of 2-3 April 1865 (Coski 2005:220). Future archaeological investigation may finally be able to resolve the question of its engine type.

CSS Nashville

Nashville was the only Confederate ironclad completed to take advantage of the availability of sidewheel riverboat machinery. Four such ironclads were originally contracted for but only *Nashville* was placed into service (Holcombe 1993:83). Contemporary sketches reveal its key design features (Figure VI.34), but no builders' drafts are known to exist. Fortunately, a Union survey of the captured *Nashville* provides significant details of the machinery layout.

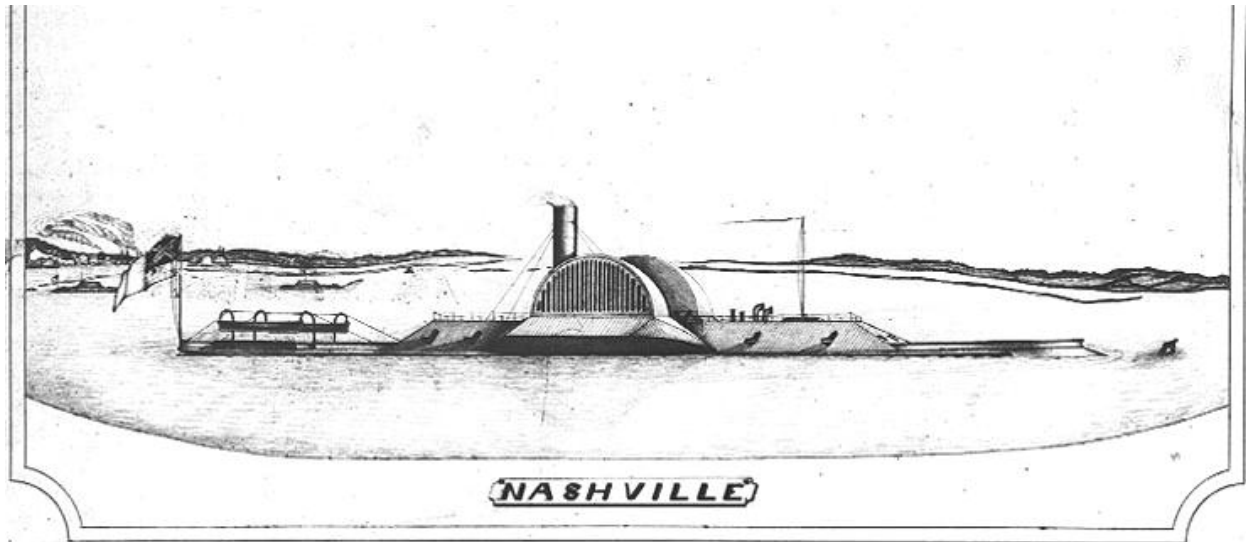

FIGURE VI.34. Contemporary drawing, circa 1865, of the large sidewheel ironclad *Nashville* (Online Library of Selected Images, Naval Historical Center, Department of the Navy, Washington, DC, 2012)

This ironclad was constructed at Montgomery, Alabama, by J.E. Montgomery and A. Anderson and was one of the largest in the Confederacy. *Nashville* measured 271 feet long overall with a hull beam of 62 feet, beam over the paddleboxes of 95.5 feet, 13-foot depth of hold, and a draft of 10 feet 9 inches (Holcombe 1993:83,91). It was taken downriver after its launch in May or June 1863 for completion at Mobile, but the usual lack of materials and labor severely delayed progress (Still 1985:195). Not least among these problems was an almost total lack of iron plating for armor and the new ship's increasingly-apparent structural weakness due to sheer size. Enough armor to cover the fore and aft casemate ends and pilot house was obtained from the rotten *Baltic* but even with this light covering, extensive use of hogging trusses and chains, and a reduced armament of three guns, *Nashville* continued to hog (Holcombe 1993:83). It was eventually surrendered at Nanna Hubba Bluff on the Tombigbee River, 40 miles above Mobile, along with several other vessels on 8 May 1865 (Still 1985:226).

Two Union reports, one by Rear-Admiral H.K. Thatcher, USN, and another by Acting Volunteer Lieutenant George P. Lloyd, USN, described *Nashville*'s power plant. There are some

minor discrepancies: Thatcher listed the engines (1 per wheel) as 30 inches in diameter with a 9-foot stroke while Lloyd listed the cylinder diameter as 32 inches (*Official Records, Navies* 1987 [Ser. 1, Vol. 22]:225; *Supplement to the Official Records of the Union and Confederate Armies* 1999 [Part 3, Vol. 3]:320). These numbers may represent bore diameter versus outside diameter of the engine cylinders. *Nashville's* 7 boilers were reported as being of the double-flued type, 30 feet long and either 40 inches (as reported by Thatcher) or 42 inches in diameter (as reported by Lloyd). Lloyd's report also listed the paddlewheels as 28 feet in diameter and 12 feet wide (*Official Records, Armies* 1999 [Part 3, Vol. 3]:320).

There is some uncertainty about the source of *Nashville's* machinery, largely due to the confusion in Union reports between this ironclad and the propeller-driven *Tennessee*. At least two reports state that the river steamer *Vicksburg's* engines were used for *Nashville* (*Official Records, Armies* 1999 [Part 3, Vol. 3]:320; *Official Records, Navies* 1987 [Ser. 1, Vol. 20]:735). It has already been discussed that the given dimensions of *Vicksburg's* engines and the time of their removal fit with the available data for *Tennessee*. Fortunately, evidence also exists for the source of *Nashville's* engines in yet another Union statement confusing *Nashville* with *Tennessee*. That report suggests they came from a wrecked Yazoo River steamboat (*Official Records, Navies* 1987 [Ser. 1, Vol. 25]:653). The only vessel in that river with machinery salvaged by the Confederates and with matching engine dimensions was the large sidewheeler *Magenta*, a wooden packet of 782 tons built at New Albany, Indiana, in 1861. *Magenta* was 265 feet long, 40 feet in beam, and 8.5 feet in draft (Way 1983:302). Given specifications for the engines and boilers fit with those reported onboard *Nashville*.

Dimensions of the steamer *Capitol's* machinery also match those of *Nashville*. *Capitol* was a fast sidewheel packet built in 1854 at Jeffersonville, Indiana. The vessel measured 224 feet

long, 32 feet wide, and 6 feet in draft (Way 1983:71). The Confederates salvaged the ship's machinery after *Capitol* was burned to prevent capture at Liverpool, Mississippi, in June 1862 (Warner 1864:229; National Archives RG 45 [AC File]: Roll 6).

CSS *Tuscaloosa*

This obscure ironclad was built in Selma, Alabama, by Henry D. Bassett and launched on 7 February 1863 (Still 1985:192). No plans of *Tuscaloosa* have been identified, but a single draft labeled “Gun Boat No. 1 with Prattville Engines” appears to depict a never-completed sister ship, one of the Tombigbee River ironclads (Figure VI.35).

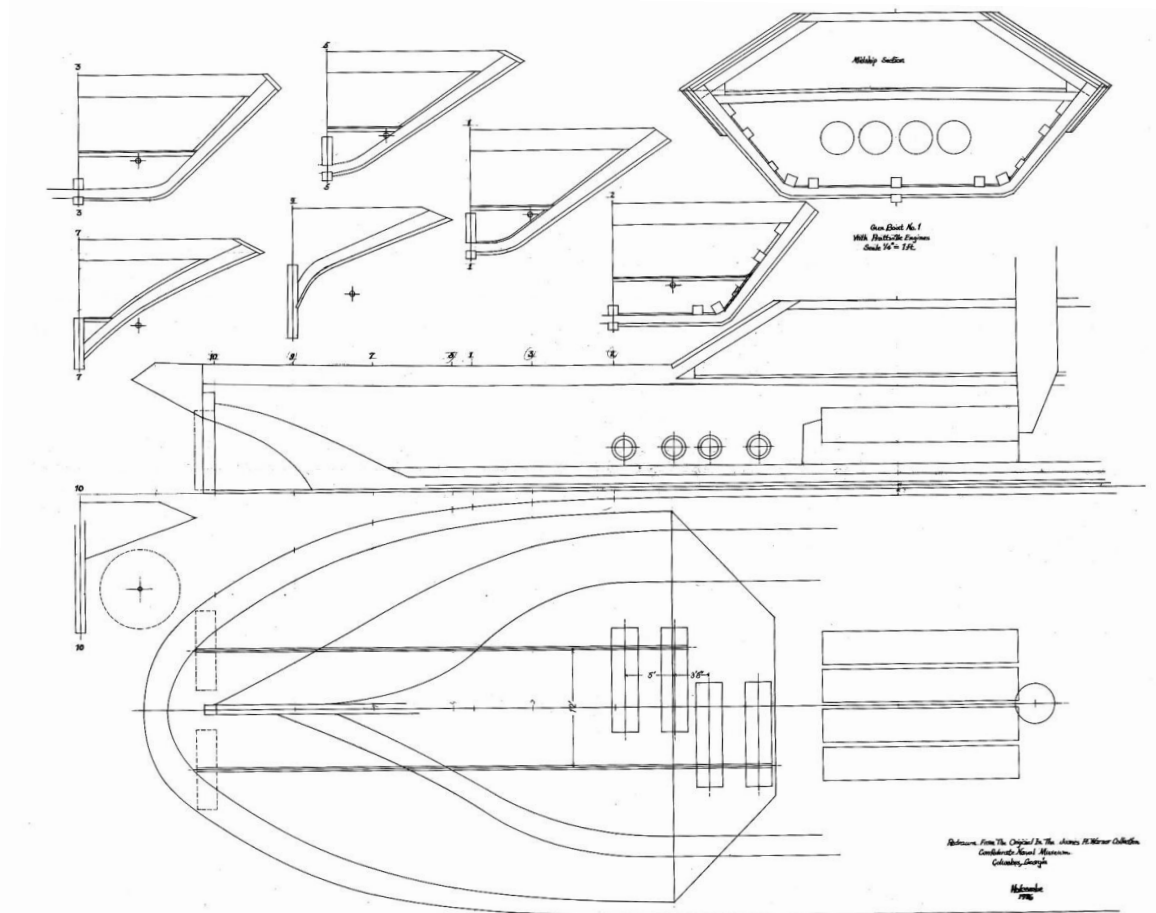

FIGURE VI.35. Partial plan view, inboard profile, and transverse sections of “Gunboat No. 1 with Prattville Engines”, redrawn by Robert Holcombe in 1976. Note the four Western river-type boilers and four engines, as well as the unusual chine construction, reminiscent of Western riverboats. *Tuscaloosa* and *Huntsville* are thought to have been constructed in a similar manner. (Courtesy of Robert Holcombe 2012)

Recent research has revealed that this vessel is probably not *Tuscaloosa* as originally thought; the unusual machinery and contemporary accounts provide the evidence (Buchanan 1863:Folder 2; Holcombe 1993:95-96). Measurements taken from the drawing show a diamond hull ironclad 43.5 feet in beam and 10.5 feet in depth of hold, with an estimated length between perpendiculars of 160 feet on a 9-foot draft (Holcombe 1993:93). These dimensions approximate those generally attributed to *Tuscaloosa* in contemporary accounts.

Tuscaloosa's machinery source is better-documented. Like *Tennessee* it was originally intended that the machinery for this vessel be built by the Columbus Naval Iron Works but there was not time or materials available to prepare purpose-built engines (Still 1985:191). Instead, high-pressure riverboat machinery from the steamer *Chewala* was reworked for *Tuscaloosa* (Turner 1999:145). *Chewala* was a 372-ton sternwheeler built in 1852 at Brownsville, Pennsylvania (Neville 1961:42). Its engines and boilers were taken out and the engines were geared to *Tuscaloosa*'s propeller shafts. If the "Gun Boat No. 1" draft indeed represents a sister vessel to *Tuscaloosa*, its machinery would have had similar dimensions if not so complicated a layout. "Gun Boat No. 1" is unusual for its 4 single-cylinder engines of 30-inch diameter and 10.25-foot stroke turning twin 7.75-foot diameter propellers. Steam was supplied by 4 boilers 3.25 feet in diameter and 19.5 feet long. *Tuscaloosa* itself had two engines and an unknown number of boilers from *Chewala*.

While the geared engine arrangement worked for *Tennessee*, *Tuscaloosa*'s was a failure. The ironclad could not make more than 2 or 3 knots even with 125 pounds of steam pressure (Still 1985:194). Consequently it served out the war as little more than a floating battery and was scuttled at the confluence of the Mobile and Spanish rivers on 12 April 1865 by the retreating Confederates (Still 1985:224-225). The wreck was located in 1983 but exploratory surveys of the

seemingly well-preserved remains failed to uncover anything new (Holcombe 1993:95). Future in-depth investigation of this valuable Civil War archaeological resource has the potential to uncover a wealth of new data.

CSS Huntsville

It appears that *Huntsville* was nearly identical to *Tuscaloosa*, but even less is known about this second Selma ironclad. *Huntsville* was built alongside *Tuscaloosa* and launched the same day. The ship was less complete than *Tuscaloosa* when launched and had to be towed to Mobile minus its boilers and engines (Still 1985:191). The origin and type of power plant eventually supplied by the Columbus Naval Iron Works is unknown—all that is stated is that it was a high-pressure system taken from a riverboat (*Official Records, Navies* 1987 [Ser. 1, Vol. 21]:363). The machinery may have come from *John C. Calhoun*, which was salvaged by the Confederates after a disastrous explosion (Way 1983:250; Mueller 1990:102). This vessel was built in 1859 at West Brownsville, Pennsylvania, and displaced 165 tons (Way 1983:250). Its engines supposedly matched those of *Chewala*, source of *Tuscaloosa*'s machinery.

During trials, *Huntsville* performed just as poorly as *Tuscaloosa*. It presumably used the same geared layout as its sister ship. Also like *Tuscaloosa*, the ironclad was relegated to a floating battery and later scuttled on 12 April 1865. Their well-preserved wrecks lie close together near Mobile, awaiting further investigation.

CSS Albemarle

The shallow-draft diamond hull ironclad type was well-suited to the rivers and sounds of coastal North Carolina and the most famous example, *Albemarle*, was completed in that state. This vessel and its sisters differed from *Tuscaloosa* and *Huntsville* based on considerable surviving evidence. A simplified, hexagonal design with integrated casemate and shallow keel

was laid out by Porter. *Albemarle* was the first of these ironclads to be completed and closely followed this pattern. The design was 139 feet long between perpendiculars, 155 feet long overall, 34 feet in beam, 9 feet in depth of hold, and 6.5 feet of draft (Holcombe 1993:96-99).

Albemarle was laid down near the Roanoke River at Edward's Ferry, North Carolina, in early January 1862 under contract to Colonel William F. Martin and Lieutenant Gilbert Elliott, CSA (Holcombe 1993:96). The ship was launched incomplete 15 months later, on 6 October 1863. Some damage to the keel was incurred, but the small ironclad was towed downstream to Halifax, North Carolina, and completed there in April 1864. The finishing touches were still being put on even as *Albemarle* was commissioned on 17 April and steamed downriver to attack Federal forces at Plymouth (Elliott 2005:115,166). The ironclad's final design differed from the original plans with an overall length of 158 feet, extreme beam of 35 feet 3 inches, on-deck width of 32 feet, 8 feet 2 inch depth of hold, and loaded draft of 9 feet (Elliott 1993:164). These dimensions come from an 18 May 1864 Union survey of the captured ship (Figures VI.36-38).

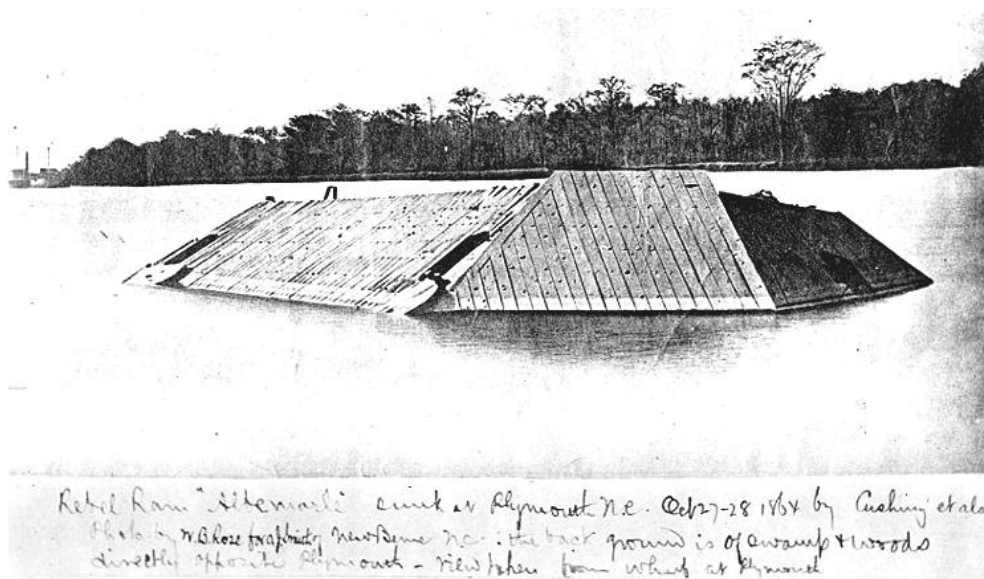

FIGURE VI.36. Original photograph of *Albemarle* sunk in the Roanoke River; the caption reads, “Rebel Ram ‘Albemarle’ sunk at Plymouth, N.C. Oct. 27-28 1864 by Cushing et als [sic]. Photo by W.B. Rose for J. Smith [?] of New Bern, N.C. The back ground is of swamp & woods directly opposite Plymouth—view taken from wharf at Plymouth.” (Online Library of Selected Images, Naval Historical Center, Department of the Navy, Washington, DC, 2012)

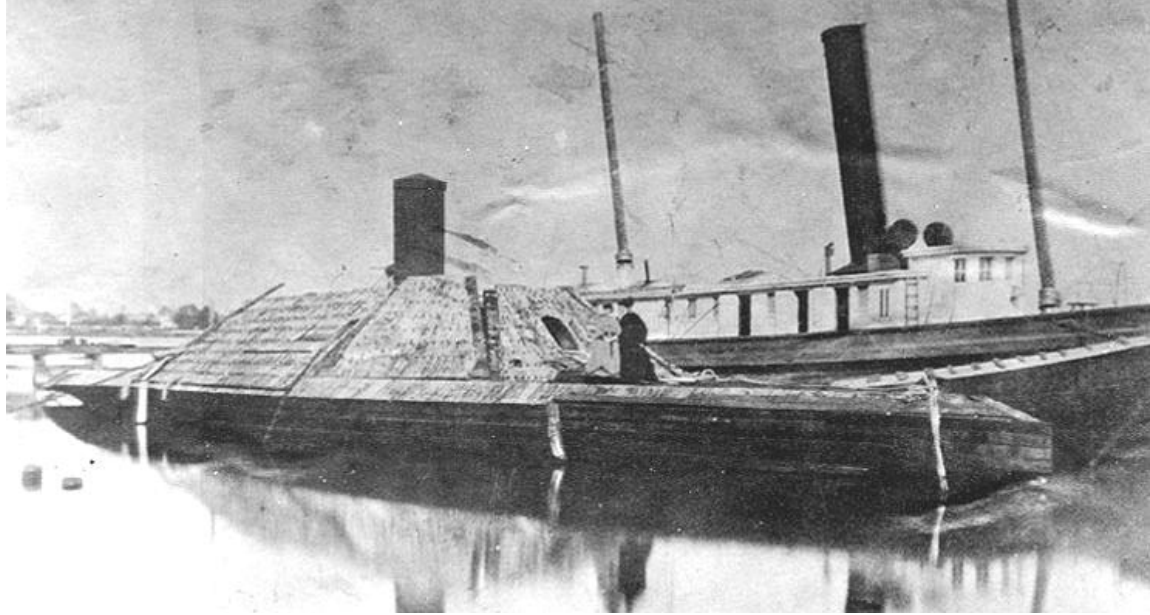

FIGURE VI.37. Photograph of the salvaged *Albemarle* at the Norfolk Navy Yard, circa 1865. The vessel is riding high in the water due to the removal of its armor. (Online Library of Selected Images, Naval Historical Center, Department of the Navy, Washington, DC, 2012)

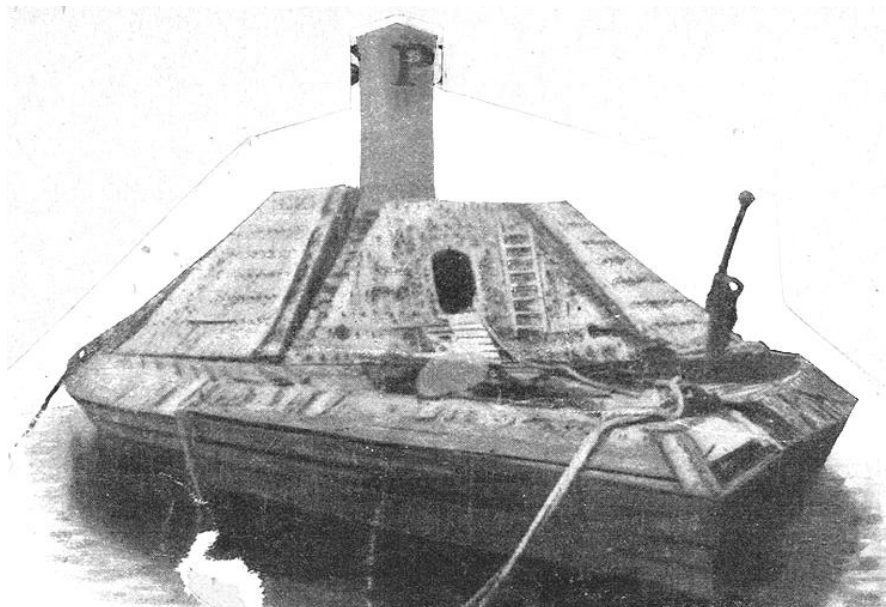

FIGURE VI.38. Close-up bow view of *Albemarle* at Norfolk. Note the lack of iron armor and dislodged casemate face at left—a result of the Confederate abandonment and attempted destruction of the ironclad after its sinking in October 1864. (Online Library of Selected Images, Naval Historical Center, Department of the Navy, Washington, DC, 2012)

Other sources suggest that the length was decreased slightly to 152 or 153 feet. The four corner gunports were also not cut, leaving only six total (Holcombe 1993:99). Figure VI.39 shows the original plans, where the differences from the finished product can be readily seen.

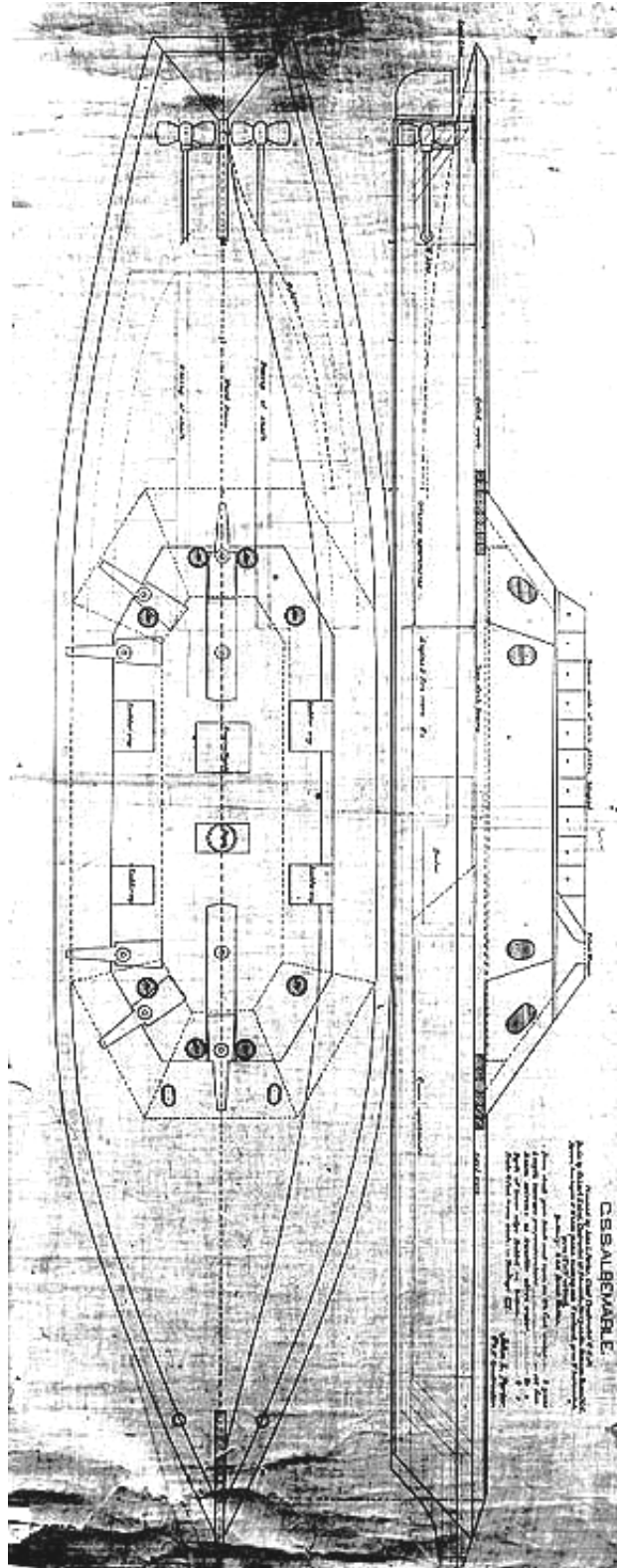

FIGURE VI.39. Original plans of *Albemarle*, showing boilers and gundeck arrangement. Note the quarter-panel gunports, eliminated on *Albemarle* but kept on *Neuse*. (Online Library of Selected Images, Naval Historical Center, Department of the Navy, Washington, DC, 2012)

Albemarle's machinery was well-documented due to its sinking and salvage by the Union in 1864, although the source remains a mystery. It has been variously listed as having been manufactured new by the Tredegar Iron Works in Richmond, reworked from a sawmill engine, or even built from scratch (Scharf 1887:404; Elliott 2005:141-142). The exact source will likely remain a mystery due to *Albemarle's* sale in 1867 (Elliott 2005:267).

The Union report described *Albemarle's* 2 engines in detail as the non-condensing horizontal type, 18 inches in cylinder diameter with a 19-inch stroke and geared to twin 3-bladed 6-foot diameter propellers by 4 gear wheels. These measured 2 feet 9.5 inches in diameter at the pitch line and the pinions measured 2.5 feet in diameter. Powering the engines were 2 vertical watertube boilers with 1 furnace each, 15 feet 4 inches in length, 5 feet 2 inches in height, and 4 feet 7 inches in diameter. The furnaces measured 4 feet 6 inches in length and 4 feet in width, while the flues were 1 foot 9 inches high and 9 inches in diameter. Each boiler was equipped with 120 watertubes and a steam drum 2 feet 8 inches in diameter and 1 foot 6 inches high. The report also made note that all the pipes and steam lines were made of cast iron (Elliott 2005:274).

CSS *Neuse*

Neuse was very similar to *Albemarle*, but generally conformed more closely to the original plans (Holcombe 1993:100). This is seen in a contemporary sketch (Figure VI.40). The ship was laid down at Whitehall (now Seven Springs) on the Neuse River in October 1862 and completed by Thomas S. Howard and Elijah W. Ellis. During construction, concerns over the ship's draft led to a significant reduction in armor plate. Changes were otherwise minimal, and *Neuse* was launched in mid-March 1863. Its completion was delayed by materials shortages after being towed downstream to Kinston. The extremely makeshift nature of this ironclad's steam machinery reflects the difficulties encountered by the Confederates. (Bright et al. 1981:8,150).

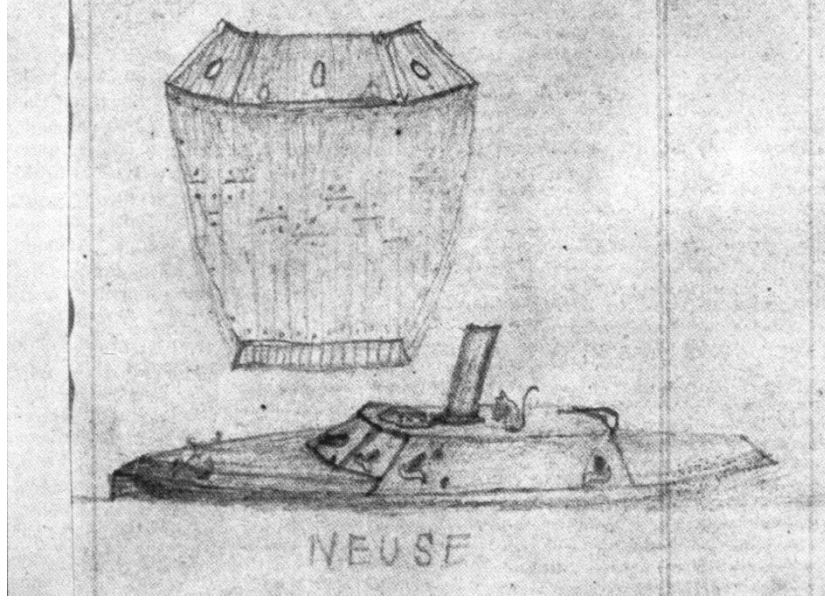

FIGURE VI.40. Contemporary sketches of *Neuse* by Lieutenant Richard H. Bacot, showing lack of armor on horizontal surfaces, an attempt to minimize draft. (Bright et al. 1981:159)

The source of *Neuse*'s two engines is uncertain—they may have come from Richmond, but are also listed as having come from Pugh's Mill in New Bern, North Carolina (*Official Records, Navies* 1987 [Ser. 1, Vol. 23]:290). It seems more likely that the engines were obtained from the same source as *Neuse*'s single 15-foot long boiler: a Baltimore & Ohio Railroad 0-8-0 “mud digger” steam locomotive (Bright et al. 1981:153). The locomotive is thought to be No. 34 “Gladiator”, built in 1844. If the engines indeed were the scavenged cylinders of this locomotive, they would have measured 17 inches in diameter with a 24-inch stroke (Bell 1912:57). Although *Neuse* was scuttled on 12 March 1865, it is unknown what happened to the machinery due to postwar salvage (Bright et al. 1981:153). Several conflicting accounts exist (Bright et al. 1981:153; Campbell 2009:58-59).

The wreck of *Neuse* was excavated and raised from 1961 to 1966. It is one of only three Civil War ironclads so preserved and is on display in Kinston, North Carolina. Unfortunately, the salvage effort resulted in the destruction of large portions of the wreck (Figures VI.41 and 42), but enough of the lower hull has been preserved for valuable construction information to be

learned (Figure VI.43). Archaeological evidence in the form of wooden mounting blocks for the engines and boiler shows that the engines were mounted next to each other on the starboard side to balance the weight of the boiler to port and must have been geared to the twin propeller shafts. The gearing arrangement was probably similar to that on *Albemarle*.



FIGURE VI.41. When first excavated, *Neuse* was largely intact, and large portions of the casemate base were preserved along with the ironclad's knuckle and main deck. (Bright *et al.* 1981:22)

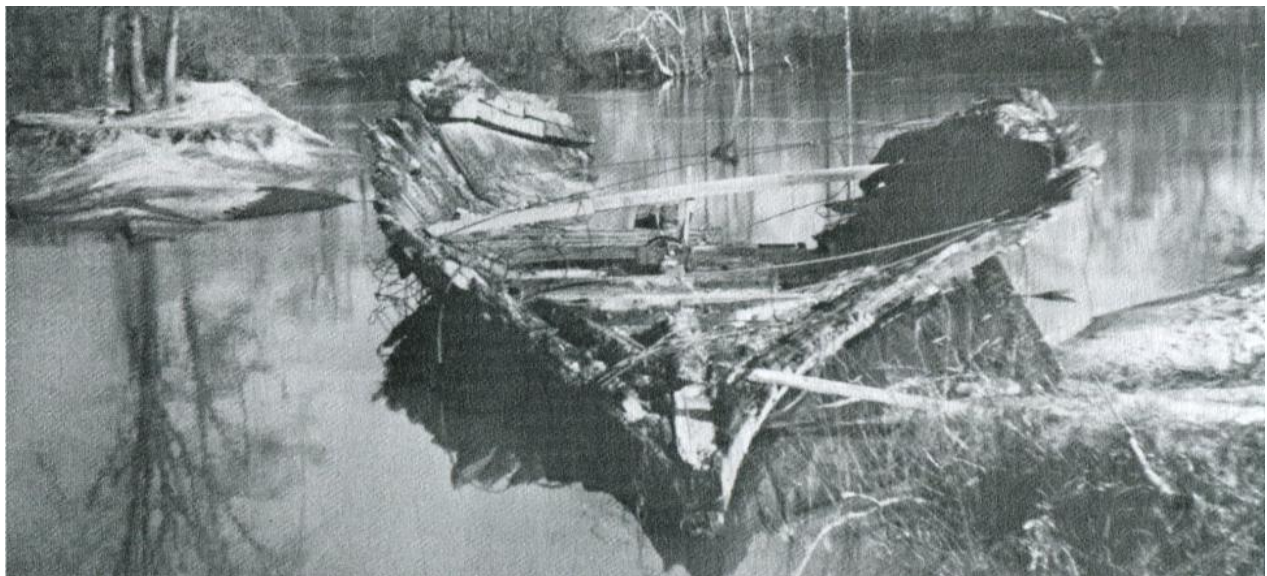

FIGURE VI.42. The salvage effort resulted in the destruction of large portions of the wreck by mishandling, vandalism, exposure, and flooding, eventually leaving only a portion of the bottom and lower hull sides. (Bright *et al.* 1981:25)



FIGURE VI.43. Until June 2012 the remains of *Neuse* lay under a roofed enclosure in Kinston, North Carolina, not far from the Neuse River. The remains of the engine, boiler, and propeller shaft mounting timbers can be seen in this view from the stern. *Neuse* has now been moved to an indoor climate-controlled facility. (Photo by author 2010)

CSS Fredericksburg

Fredericksburg was the first ironclad to be built entirely in Richmond, at a newly-established shipyard in the Rocketts suburb (Coski 2005:81). This vessel was laid down in the spring of 1862 and designed from the outset by Constructor Porter as an enlarged *Albemarle* type capable of carrying four guns. As a result, *Fredericksburg*'s dimensions were increased to 170 feet long between perpendiculars, 188 feet overall, 40 feet in beam, 10 feet 10 inches depth of hold, and a 9 or 10-foot draft (Holcombe 1993:103-105). In overall appearance it closely resembled *Albemarle* but had twin pilothouses and a rectangular casemate (Figure VI.44).

Fredericksburg was successfully launched on 11 June 1863 after a failed attempt on 6 June, but was not completed until early 1864 for want of materials (Coski 2005:85-86). Little is known about the exact source and dimensions of its machinery. It is currently thought that either Tredegar Iron Works or the Shockoe Foundry (Confederate Naval Works) in Richmond built and installed the ship's boilers and other mechanical components (Dew 1966:265; Still 1994:68; Coski 2005:72). No definitive information has yet been found.

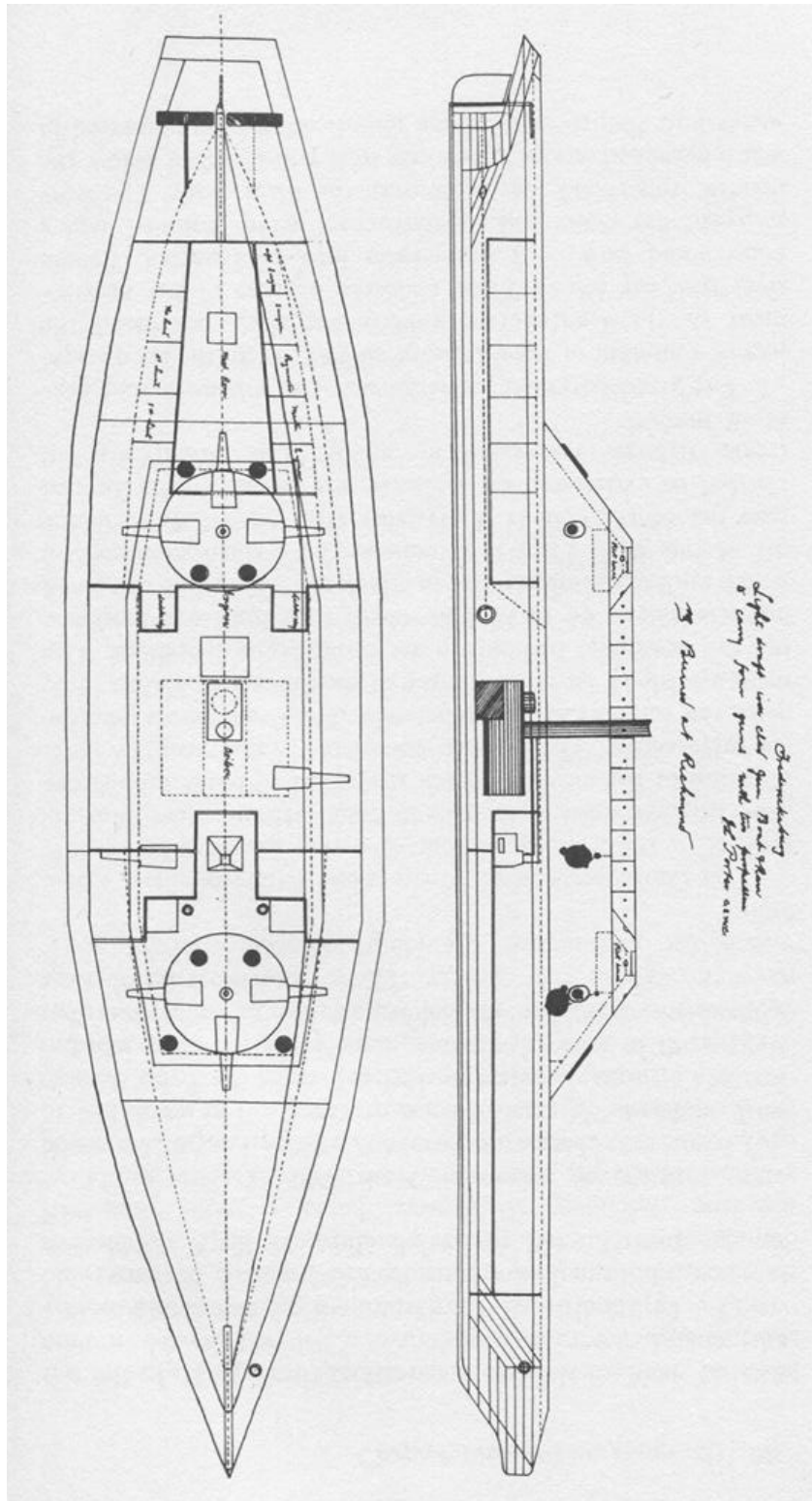

FIGURE VI.44. Original plans of *Fredericksburg*: “Light draft iron clad gun Boat & Ram, to carry four guns with two propellers—J.L. Porter, C.S.N.C. Burned at Richmond.” The single engine cylinder shown does not present enough detail for any conclusions to be made on the power plant’s source or final configuration. (Still 1987:22)

According to the extant plans, *Fredericksburg* was powered by 3 cylindrical boilers approximately 15 feet long, 5 feet in diameter, and 7 feet high. The engine layout is shown by a single circle scaled to 24 inches in diameter. There is no way of knowing if this represents the actual engine size as installed because no other information has been found. Two propeller shafts are shown turning twin 7-foot diameter screws, but the method of their connecting with the engines is also not shown—they may have been geared similarly to *Albemarle* and *Neuse*. Fortunately, this missing information has the potential to be uncovered by archaeological investigation. *Fredericksburg* was blown up and sunk to prevent capture on the night of 2-3 April 1865 (Coski 2005:220). Its wreck lies in unknown condition in the mud of the James River.

CSS *Missouri*

In addition to the light draft twin-screw design of diamond hull ironclad, Constructor Porter designed a vessel of similar form and draft to be driven by a center (or recessed) paddlewheel (Holcombe 1993:105). The first and only example of this ironclad type to be constructed as designed was *Missouri*, laid down in December 1862 and completed by steamboat captains Thomas Moore and John Smoker (Jeter 1987:267-268). *Missouri* was launched on 4 April 1863 and retained the same layout on different dimensions from the original plans. They illustrate a vessel 193 feet long overall, 56 feet in molded beam, 58 feet in extreme beam, 9 feet 9 inches in depth of hold, and a loaded draft of 6 feet. *Missouri* measured 183 feet in overall length, 53 feet 8 inches in beam, 10 feet 3 inches in depth of hold, and 8.5 feet in draft (Holcombe 1993:108).

Interestingly, *Missouri* shared a number of characteristics with a widely-used class of Union river ironclad: the seven “City-class” vessels constructed in the autumn of 1861. These were also centerwheel casemate ironclads with similar dimensions. They measured 175 feet long

on deck, 51 feet 2 inches in beam, 6 feet in depth of hold, and 6 feet in draft (Holcombe 1993:108). One of these vessels, USS *Cairo* (Figure VI.45), was sunk by a torpedo (mine) on 12 December 1862 and raised 102 years later in December 1964 (Sheppard 1990). Compare its appearance with the Confederate centerwheel ironclad plans (Figure VI.46). *Cairo* is now on display at Vicksburg, Mississippi, and represents one of three preserved Civil War ironclads. It is also the only one with paddlewheel machinery, making for an effective comparison with the Confederate *Missouri*. It is unknown whether the design of these two ironclads was conceived independently for operation in a similar environment or knowingly adapted for Confederate use by Constructor Porter (Holcombe 1993:107-108).

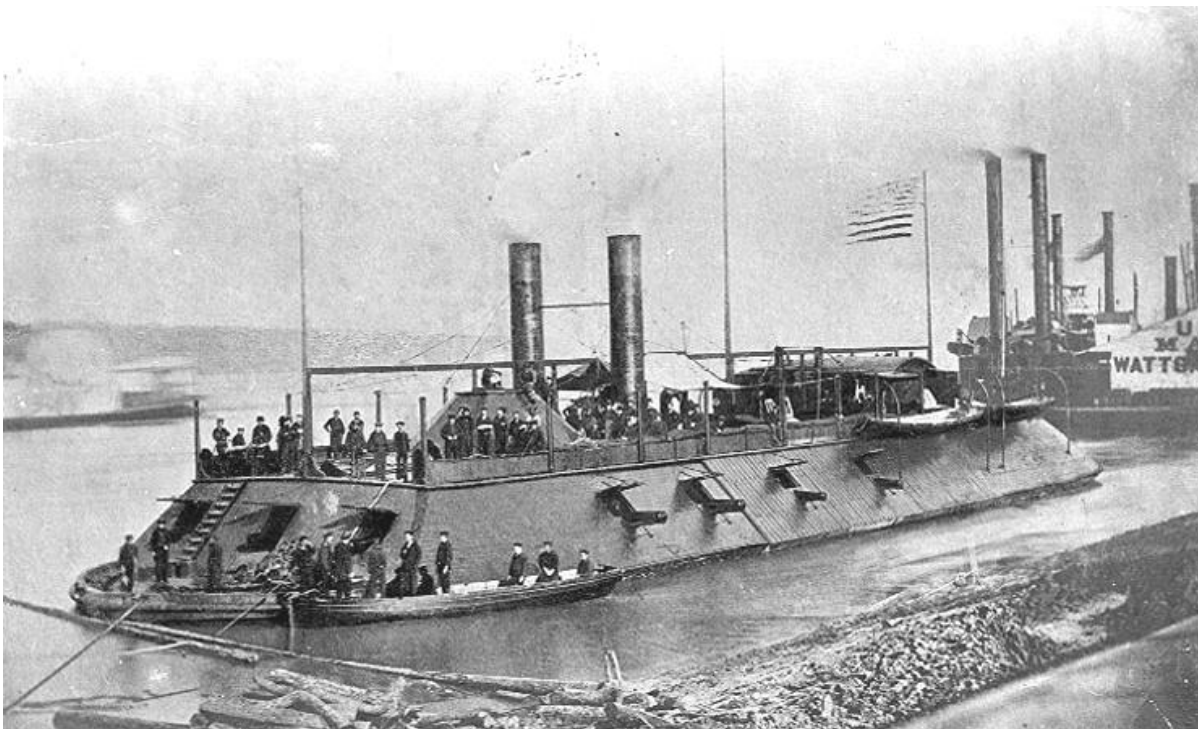

FIGURE VI.45. USS *Cairo* was the first of seven “City-class” Union gunboats to serve on the Western rivers. They were very similar in design to CSS *Missouri*. (Online Library of Selected Images, Naval Historical Center, Department of the Navy, Washington, DC, 2012)

Missouri's 2 engines and 4 boilers may have been removed from a 240-foot long, 40-foot beam, 7.5-foot draft sidewheel riverboat named *Grand Era* (ex-*R.W. McRea*) that was built at Jeffersonville, Indiana, in 1853 (Way 1983:196). The steamboat *T.W. Roberts* is another possible

candidate (A. Robert Holcombe, Jr. 2012, elec. comm.). This vessel was a 288-ton sidewheel packet measuring 158 feet long and 32 feet wide with a 6.1-foot draft (Way 1983:443). There is some confusion regarding the exact whereabouts, identities, and fates of these two boats during and after *Missouri*'s construction. Evidence currently points towards *T.W. Roberts* due to statements in contemporary correspondence noting the former owner of the boat purchased for *Missouri*'s machinery (Jeter 1996:6).

A Union survey of the captured *Missouri* in June 1865 revealed its machinery details. The single-cylinder inclined poppet-valve engines measured 24 inches in diameter, 7.5 feet in stroke, and were fitted to turn a single 22.5-foot diameter, 17-foot wide paddlewheel. A major design fault was that the top 8 feet 4 inches of the wheel were exposed above the casemate top. Powering the ship were 4 horizontal double-flued boilers 26 feet long and 40 inches in diameter with 15-inch diameter flues. The report also noted a single doctor engine, 1 donkey boiler 8 feet long and 26 inches in diameter, and 2 donkey engines—one for running the capstan and the other turning a 3-foot diameter fan blower. The only other Confederate ironclads known to be so equipped were *Atlanta* and *Tennessee* (Jeter 1987:287).

A look at USS *Cairo*'s preserved propulsion system reveals the same layout: the boilers were placed in the hold for protection and the inclined engines extend up onto the gundeck to turn the wheel (Figure VI.47). Although *Cairo* had 5 boilers, they were the same high-pressure horizontal type as most riverboats and even had similar dimensions to *Missouri*'s. They measured 36 inches in diameter and 26 feet long with 7.5-inch diameter flues (Sheppard 1990). The 2 cast iron engines were the typical riverboat type and closely resembled *Missouri*'s: they were mounted at a 15-degree angle and were 22 inches in cylinder bore with a 72-inch stroke (Sheppard 1990). Figures VI.48 and VI.49 show schematics of the engines and boilers.

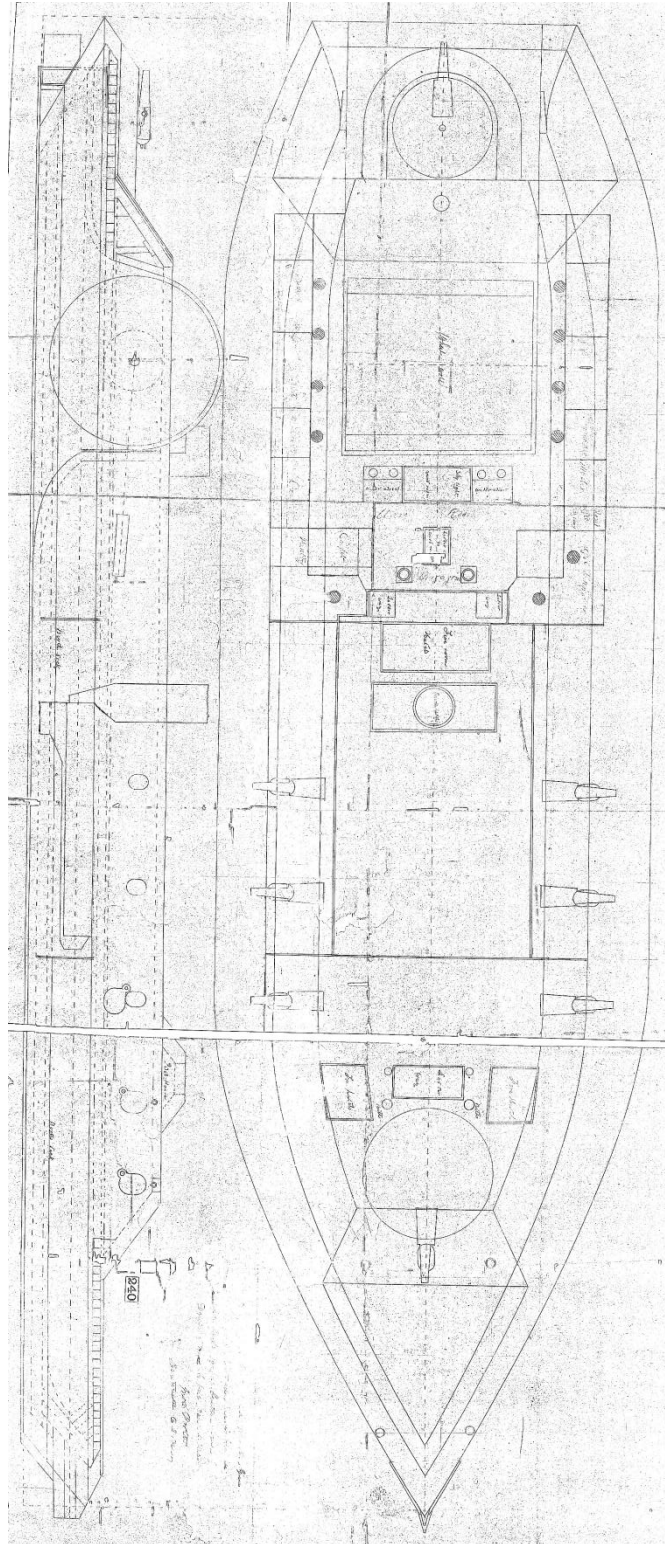

FIGURE VI.46. Original plans of Porter's light draft diamond hull centerwheel ironclad. The only ironclad completed with this general layout was *Missouri*, although it was altered to carry two pivot guns forward and the exposed stern gun position was eliminated. (Courtesy of Robert Holcombe 2012)



FIGURE VI.47. A view looking aft along the reconstructed *Cairo*'s port side gundeck, showing the port engine and pitman arm angling up through the deck to connect with the center paddlewheel. The internal arrangement of *Missouri* would have been similar. (Sheppard 1990)

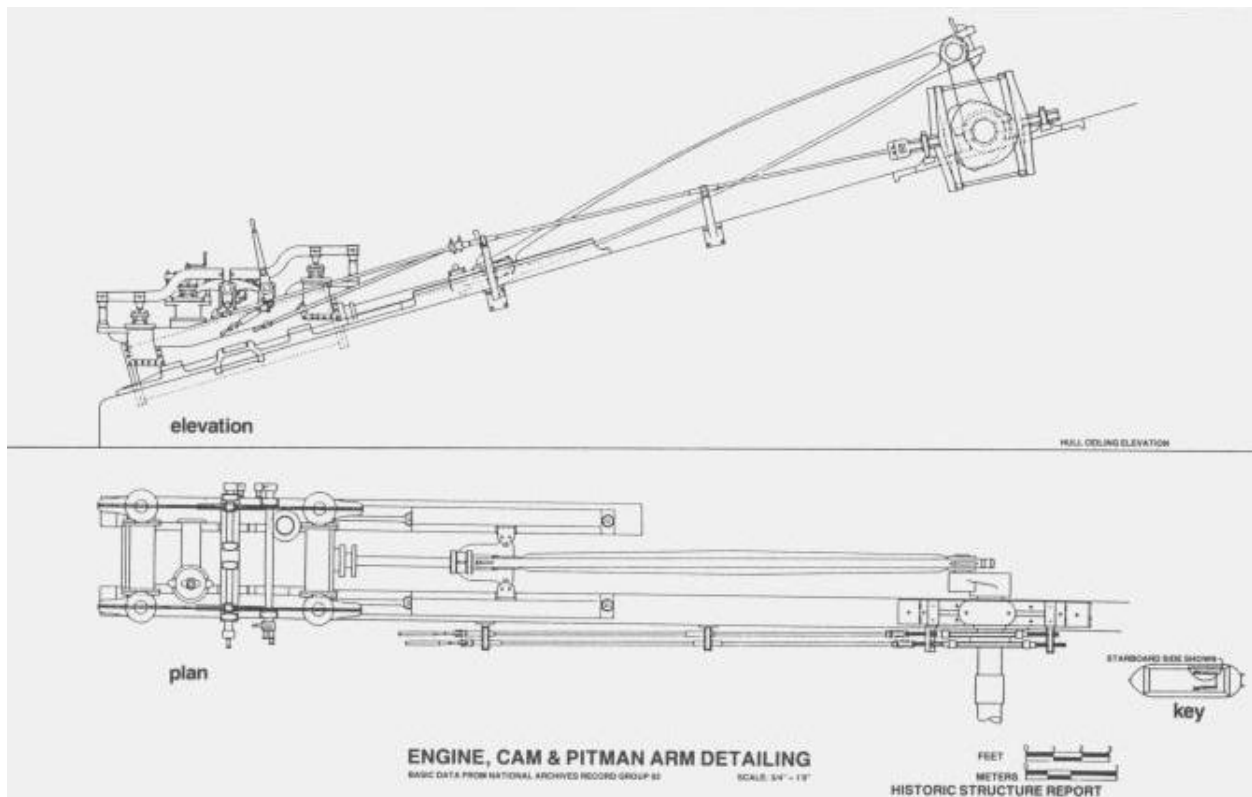

FIGURE VI.48. Engineering drawing of *Cairo*'s engine configuration (Sheppard 1990)

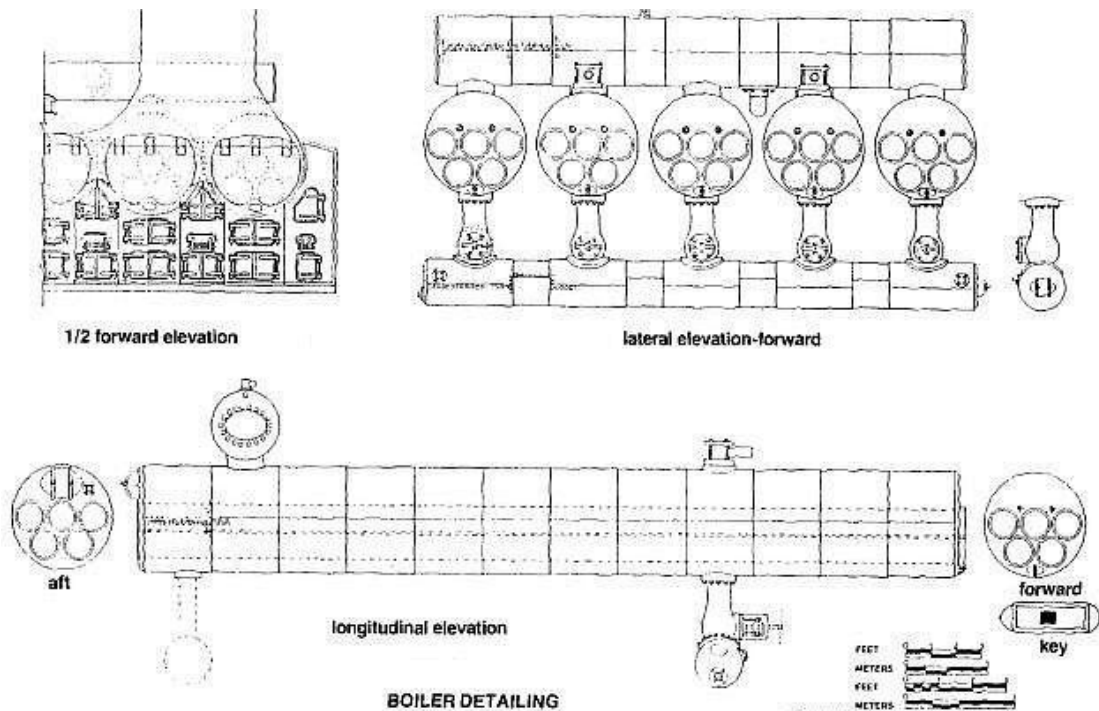

FIGURE VI.49. Engineering drawing of *Cairo*'s boiler configuration (Sheppard 1990)

Unlike the Union vessel, *Missouri* was never sunk or preserved but instead taken to Mound City, Illinois, and sold for scrap (Jeter 1987:287-288). It is therefore quite fortunate that *Cairo* survives, for it is the only preserved paddlewheel-driven Civil War vessel in existence.

CSS *Mississippi*

The construction of the largest and most powerful ironclad built in the Confederacy was begun at the same time as *Louisiana* in a new shipyard at Jefferson City, Louisiana, just upriver from New Orleans (Still 1985:43). Asa and Nelson Tift, who had no shipbuilding experience but were prewar friends of Secretary Mallory, submitted plans for an enormous vessel to be driven by three screws and built without curved surfaces. This conception was a result of the brothers' perceptive realization that the South lacked experienced shipwrights (Holcombe 1993:44). *Mississippi* was, therefore, constructed more like a ferry or flat than a ship (CSA 1863:125). Two rough sketches drawn by the Tifts of this unusual design exist in the Confederate inquiry records on the loss of New Orleans (Figures VI.50 and 51).

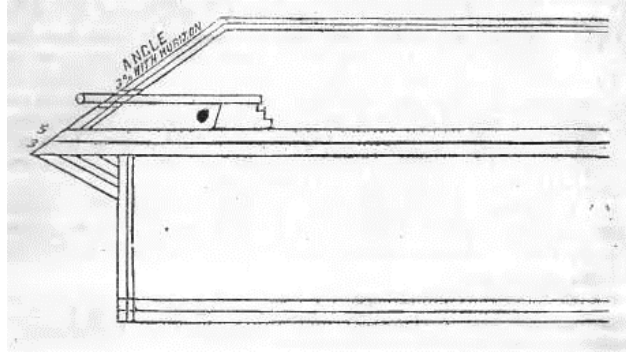

FIGURE VI.50. Sketch by Asa or Nelson Tift of *Mississippi*'s cross-sectional shape (Confederate States of America [CSA] 1863:165)

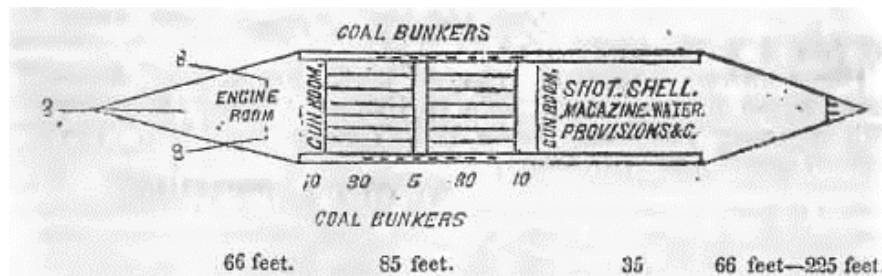

FIGURE VI.51. The Tift's sketch of *Mississippi*'s general machinery layout (CSA 1863:159)

The first plank of *Mississippi* was laid on 14 October 1861, but construction lagged despite the simplicity of the ship's design and its location adjacent to the South's largest shipbuilding center (Still 1985:44). Among the most significant reasons for delay was *Mississippi*'s sheer size: 240 feet long between perpendiculars, 58 feet in extreme beam, and 15 feet in depth of hold (Holcombe 1993:44). The length was increased by 20 feet during the course of construction when it was found during a consultation with experienced engineers that the existing boiler layout had insufficient grate and fire surface area to effectively propel the ship (CSA 1863:159). *Mississippi*'s original design called for "...11 boilers 32 feet long and 42 inches in diameter, 2 return flues [sic], with mat [mud] drum 24 inches in diameter, steam driver [drum] 30 inches in diameter, about 40 feet long..." (CSA 1863:155). This already-large system had to be upgraded to 16 double-flued boilers 42 inches in diameter and 30 feet long, capable of generating approximately 1,500 horsepower (CSA 1863:159).

Mississippi's triple 11-foot diameter propeller arrangement was one of the first such systems ever built and required powerful engines of 36-inch bore and 30-inch stroke (Holcombe 1993:45). These engines were high-pressure horizontal direct-acting and were optimistically projected to drive *Mississippi* at 14 knots (Holcombe 1993:45). Both boilers and engines, in addition to two doctor engines, two blowers, and two steam pumps were constructed by the Patterson Iron Works (formally known as Jackson & Co.) of New Orleans (CSA 1863:155-156). The large central propeller shaft was forged with some difficulty by Tredegar while the wing shafts were forged by Clark & Co. of New Orleans (CSA 1863:112). The delays occasioned by the machinery revisions and making the shafting delayed *Mississippi's* launch date until 19 April 1862, just days before the Union captured New Orleans. As a result, the Confederacy's greatest warship was burned to prevent capture after several attempts to tow the hulk upriver failed (Still 1985:59). Figure VI.52 shows *Mississippi* as it would have appeared if completed.

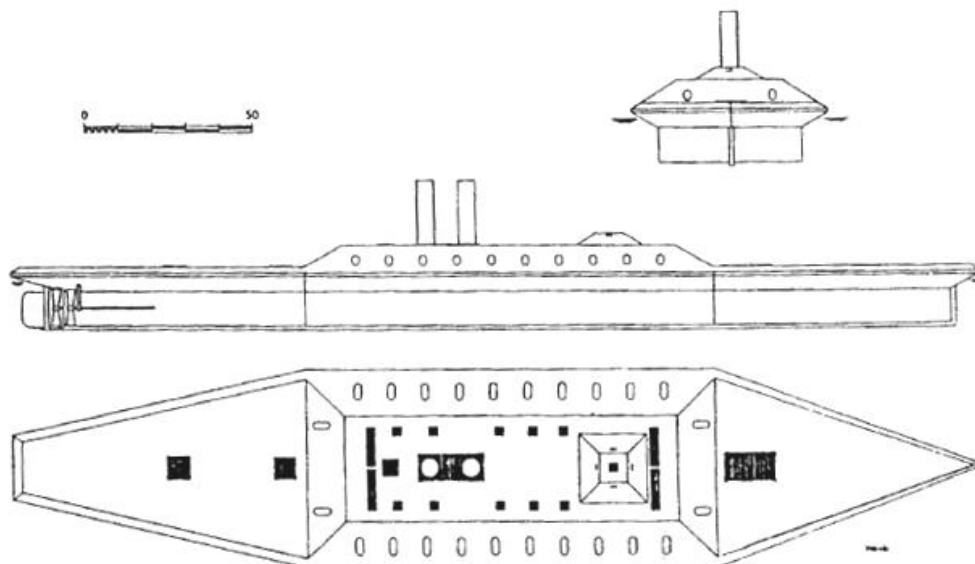

FIGURE VI.52. *Mississippi* as it would have appeared completed (Holcombe 1993:45)

CSS Jackson

Jackson, also commonly called *Muscogee*, was the second diamond hull centerwheel ironclad to be laid down. The ship was built at the great industrial center of Columbus, Georgia,

next to the Naval Iron Works but suffered from continuous construction problems and became “...the most altered ironclad built in the Confederacy” (Holcombe 1993:109). These changes were not represented in the historical record but are well-documented archaeologically due to the ironclad’s recovery in the early 1960s (Holcombe 1993:110).

Jackson was originally laid down in December 1862 but was not successfully launched until after its major reconstruction into a twin-propeller vessel was recommended by Constructor Porter (Turner 1999:176). Porter’s visit was a result of a failed launch attempt on 1 January 1864 in which it was revealed that *Jackson* was too heavy to float off the blocks even with the bow partially afloat (Turner 1999:170). This disturbing fact, coupled with a realization of the design’s unsuitably deep draft, called for the reconstruction (Figure VI.53) and further delayed completion. *Jackson* was not successfully launched until 22 December 1864 (Turner 1999:214). The single existing photograph of the ship (Figure VI.54) was apparently taken soon afterward.

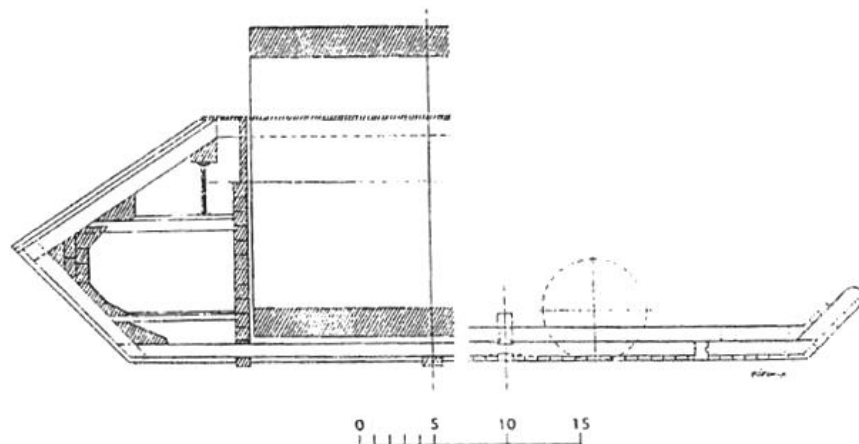

FIGURE VI.53. *Jackson*’s original centerwheel design, left, and final twin-screw design, right (Holcombe 1993:110)

Jackson’s original design conformed closely to Porter’s centerwheel ironclad plans but had to be extensively lengthened at the stern for twin-screw propulsion. This ultimately resulted in a vessel approximately 225 feet long overall, 59 feet in extreme beam, and 7 or 8 feet in loaded draft (Holcombe 1993:110-111). The paddlewheel machinery previously obtained for and

installed in the ship had to be removed (McLaughlin 1864:13 July Letter). Its source is known—the 263-ton sidewheeler *Time*, built in 1860 at Louisville, Kentucky (Neville 1961:42).

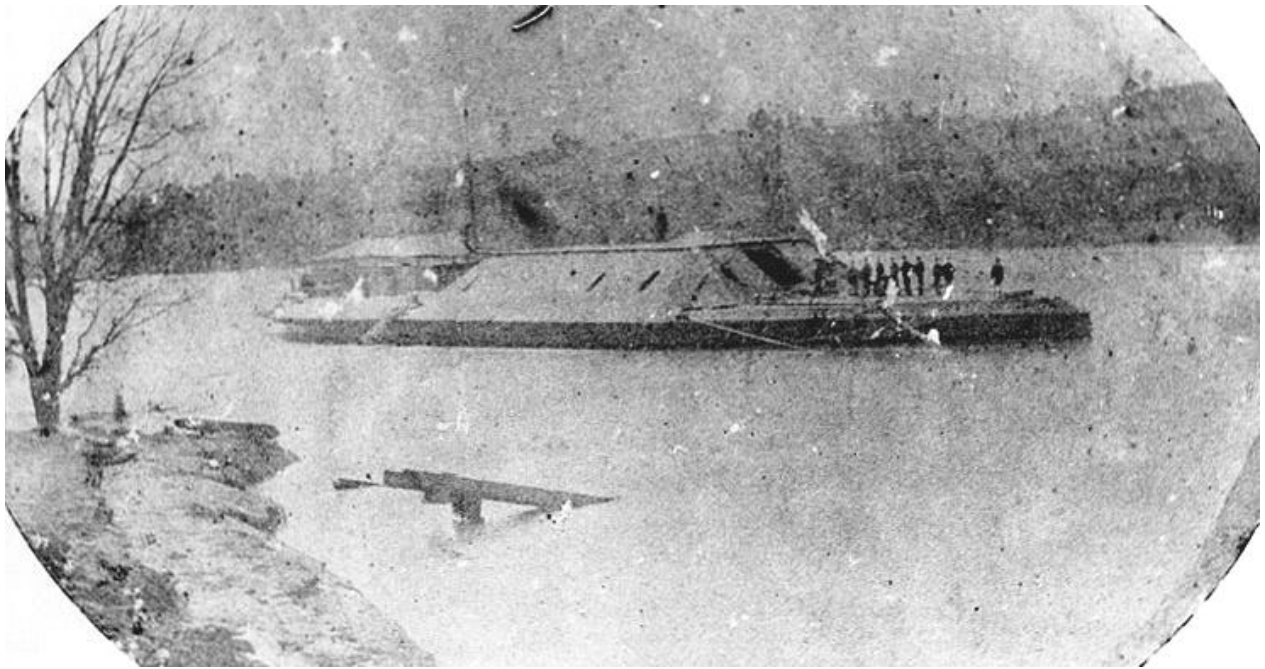

FIGURE VI.54. Original photograph of *Jackson* taken soon after launching, December 1864. The ship floats high in the water without armor or machinery—the opening in the front of the casemate was left for installation of the latter. An awning spread on the aft flush deck nearly obscures the wooden gunboat CSS *Chattahoochee* moored behind the ironclad. (Online Library of Selected Images, Naval Historical Center, Department of the Navy, Washington, DC, 2012)

A recently-discovered drawing of this ship's engines, labeled "Muscogee's Engines", along with another un-labeled drawing that appears to represent the same machinery (Figures VI.55-56) reveal the approximate cylinder diameter to be 30 inches. Other measurements regarding the boilers and stroke length are unknown because they are not represented. The four boilers from *Time* in the original design seem to have been kept in *Jackson*'s second incarnation as a propeller-driven vessel (Campbell 2009:82).

The second set of engines supplied for *Jackson* were purpose-built by the adjacent Columbus Naval Iron Works and were of the typical horizontal single-cylinder direct-acting type, measuring 36 inches in bore and stroke (Campbell 2009:83). Each engine independently

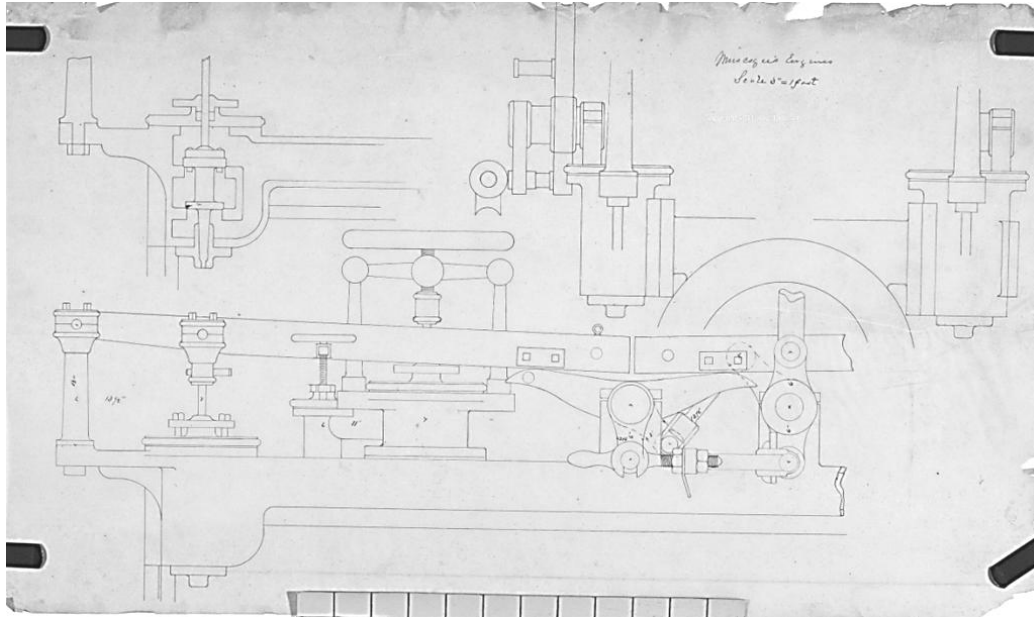

FIGURE VI.55. Original engineering diagram of “Muscogee’s Engines”. Unfortunately, the whole cylinder is not shown, nor is the identity of the draftsman given. (Courtesy of David Rousar 2012)

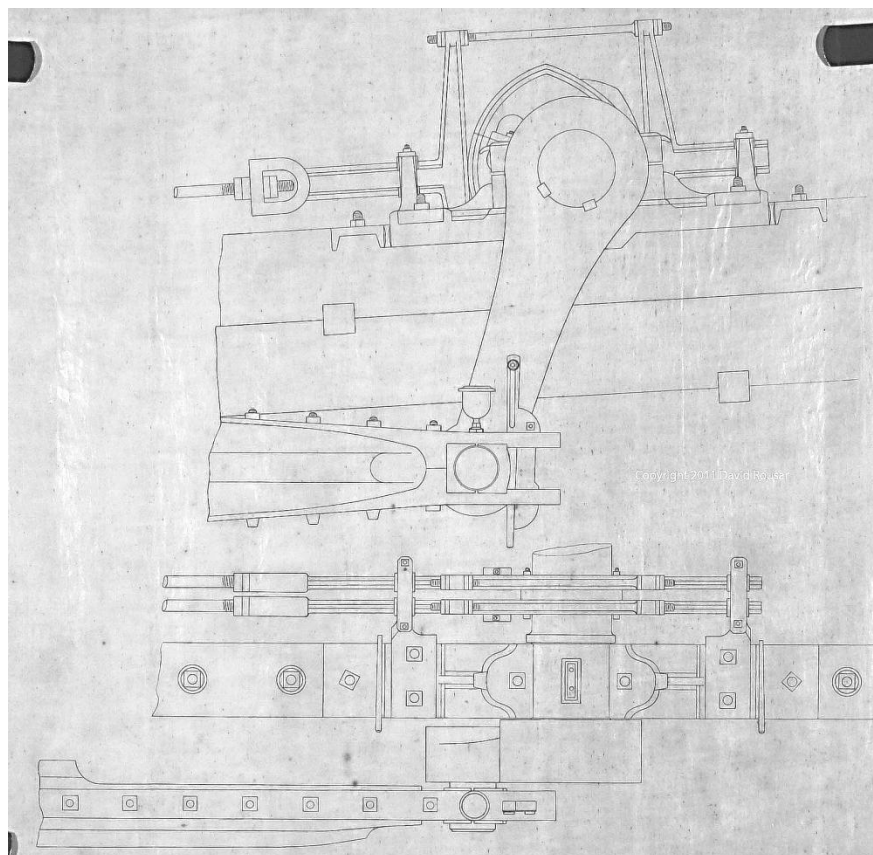

FIGURE VI.56. Original engineering diagram of unidentified pitman arm, crank, and cams. The style of the drawing matches that of the previous figure and suggests *Jackson’s* original paddlewheel engines. (Courtesy of David Rousar 2012)

turned a 7.5-foot diameter screw mounted on a 6.75-inch diameter shaft. The mounting timbers of the engines are preserved today (Figure VI.57), as are the ends of the shafts (Figure VI.58).



FIGURE VI.57. Large timbers for supporting the engine mounts of *Jackson* as preserved today. They are approximately 12 inches square. The boiler bed mountings were farther forward, but those timbers were not preserved. (Photo by author 2011)



FIGURE VI.58. *Jackson*'s twin 7.5-foot diameter iron propellers and the sections of the shafts where they pass through the hull are preserved on the wreck today. (Photo by author 2011)

While the engines of *Jackson* no longer exist, those of the wooden Columbus-built gunboat CSS *Chattahoochee* are preserved at the Port Columbus Civil War Naval Museum (Figures VI.59-63). These represent the only preserved examples of the preferred engine type for Confederate ironclads and measure 28 inches in bore, 34.5 inches in exterior diameter, and 20 inches in stroke. In addition, *Chattahoochee*'s preserved stern effectively shows how the machinery was mounted (Figure VI.64).

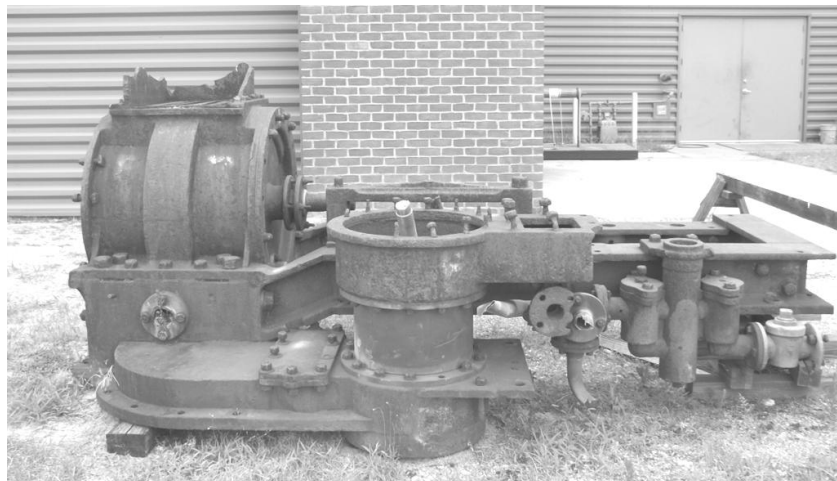

FIGURE VI.59. Starboard engine of *Chattahoochee*, which turned the port propeller. Both of the gunboat's massively-constructed engines are preserved, but this one is in better condition. The remains of the valve chest can be seen on top of the cylinder, and the condenser is prominent in the center of the assembly. (Photo by author 2011)



FIGURE VI.60. Front of the starboard engine. The cylinder head has been removed, showing the 28-inch diameter piston. (Photo by author 2011)



FIGURE VI.61. *Chattahoochee*'s starboard engine seen from above. The condenser, left, part of the crosshead guides for the connecting rod, and piston rod can be clearly seen. (Photo by author 2011)



FIGURE VI.62. The 34.5-inch diameter cylinder head for one of *Chattahoochee*'s engines. The valve was used for the occasional drainage of condensed steam from the cylinder. (Photo by author 2011)



FIGURE VI.63. Side view of the cylinder head, showing thickness of solid iron construction. (Photo by author 2011)



FIGURE VI.64. Engine mounting timberwork for the starboard engine in the preserved stern section of *Chattahoochee*. The timbers measure 9 inches sided by 12 inches molded on average, and the bolts measure 1.25 inches in diameter. Part of the port propeller shaft connecting assembly can be seen at the top of the image. (Photo by author 2011)

The machinery mountings on *Jackson* were similar but more working room was provided by the large ironclad's wide hull. Other machinery parts representing a thrust bearing and parts of a reversing gear (Figures VI.65-67) from one of these two vessels are also located on the museum grounds.



FIGURE VI.65. Large cast iron thrust bearing mounting block from either *Jackson* or *Chattahoochee*. (Photo by author 2011)



FIGURE VI.66. Part of reversing gear assembly for either *Jackson* or *Chattahoochee*. (Photo by author 2011)



FIGURE VI.67. More parts of reversing gear assembly. The bricks at right were initially thought to be boiler bed firebricks but are not from either vessel. (Photo by author 2011)

Jackson's late launch date resulted in its never being finished, and the ship was set on fire by invading Union troops on 17 April 1865 (Turner 1999:237). The burning ironclad drifted downstream for 30 river miles before grounding; in 1910 the Army Corps of Engineers dredged around the wreck and removed the machinery (Campbell 2009:79). The recovered remains are now on display at Port Columbus. They have provided significant information on the construction of diamond hull ironclads, as well as *Jackson's* ill-fated design changes.

CSS Milledgeville

This one-off vessel was a late-war design intended to be an improvement over the earlier standard hull types such as the *Richmond*-class (Holcombe 1993:123). As such, *Milledgeville* had a similar hull structure to earlier ironclads but incorporated significant design changes. Fortunately, these changes are shown in extant plans of the ironclad bearing Constructor Porter's signature (Figure VI.68). *Milledgeville* was a twin-screw standard hull ironclad laid down in February 1863 by H.F. Willink, constructor of *CSS Savannah*. It was 175 feet in length between perpendiculars, 185 feet in overall length, 35 feet 2 inches in molded beam, and 48.5 feet in

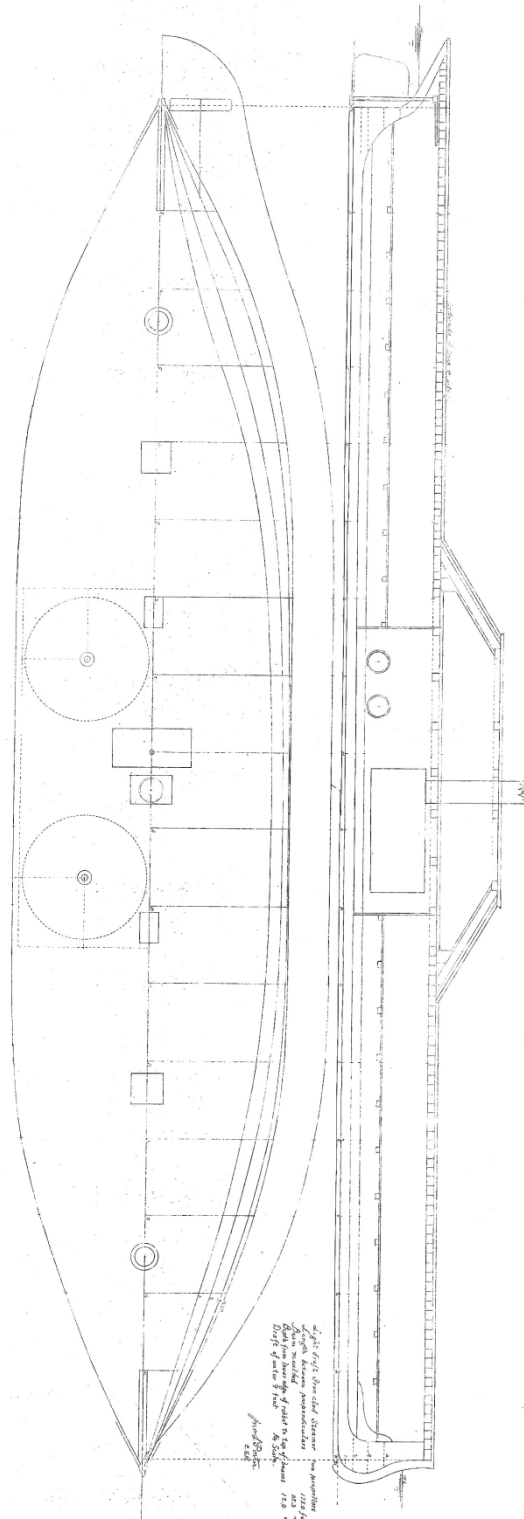

FIGURE VI.68. Porter's plans of *Milledgeville*, showing details of engineering and gundeck arrangements. The final configuration of *Milledgeville*'s power plant was reportedly nearly identical to other Columbus-built examples. (Emory University Archives 2011: Collection Number 243, Plan File CX1)

extreme beam (Holcombe 1993:125). It featured the late-war improved flush deck design of *Columbia* and a shortened casemate with 6 inches of armor. Most importantly, the ship had an increased depth of hold of 12 feet, resulting in a reduced draft of 9 feet (Holcombe 1993:125).

The *Milledgeville* plans also show the general machinery arrangement of the ship, although its final configuration may have differed slightly. Two approximately 30-inch diameter single-cylinder horizontal engines are shown in the starboard plan view along with a 14-foot long, 6-foot diameter boiler. Dimensions taken off the plans show that *Milledgeville* had two boilers, although the half-breadth / gundeck plans do not show them from above. Twin 7-foot diameter propellers are shown at the stern. All of the machinery was built by the Columbus Naval Iron Works and should have given good service (Holcombe 1993:126).

Milledgeville's completion was severely delayed like many other Confederate ironclads. Willink's prior commitments and design changes made to the ship while under construction were the biggest factors (Holcombe 1993:123). *Milledgeville* was launched in early fall 1864 and nearly complete when burned to prevent capture by Union forces on 21 December 1864 (*Dictionary of American Naval Fighting Ships* 1963 [Vol. 2]:549). The ship's engines and most of its armor had been installed by that time, but were mostly salvaged by the Army Corps of Engineers in the 1890s (Judy Wood 2011, elec. comm.). The current condition of the wreck is unknown—future archaeological survey of the site may uncover new details.

CSS *Wilmington*

The design of the last ironclad constructed at Wilmington and informally named for that city (an official naming ceremony never seems to have occurred) reflected both lessons learned in ironclad design and the unique nature of its probable mission. *Wilmington* was one of the very last Southern ironclads to approach completion. It was never launched and was burned on the

stocks as Federal troops reached the Confederacy’s last open port in February 1865 (Holcombe 1993:127,130). Fortunately, enough information exists on this unique vessel for an accurate reconstruction to be made—an engineering diagram (Figure VI.69) and the original plans (Figure VI.70) have been preserved.

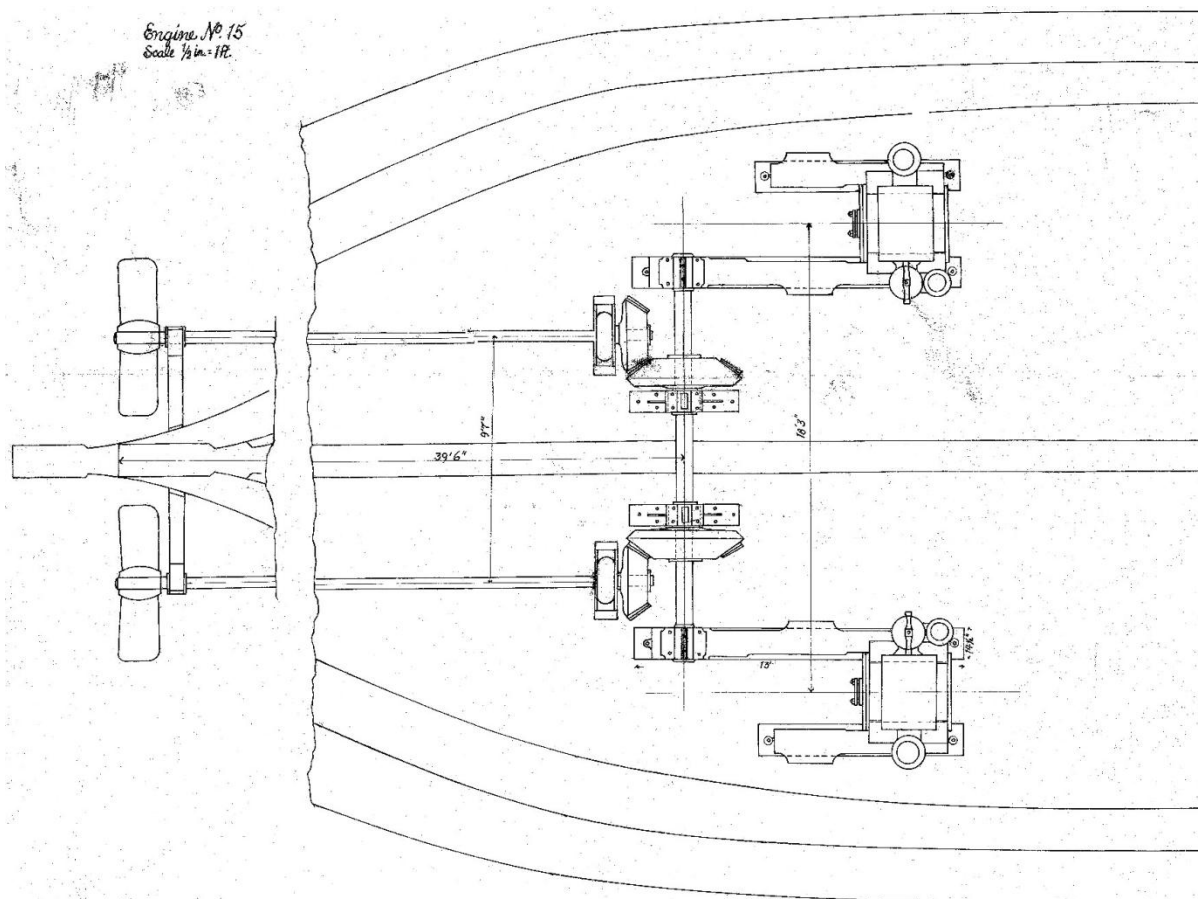

FIGURE VI.69. Robert Holcombe’s 1981 re-drawing of an engineering diagram of a twin-screw vessel fitted with “Engine No. 15.” Dimensions and layout indicate that this vessel is *Wilmington*. Note that the plans do not show the piston or connecting rods. (Courtesy of Robert Holcombe 2012)

Wilmington was designed by Constructor Porter as an effective replacement for the wrecked *Raleigh* and rotten *North Carolina* in May 1864. It was laid down at the Beery shipyard on Eagles Island where *North Carolina* was built and some of the armor from that ship was actually used in construction. The design of this ironclad reflects a possible intention for use as a blockade-breaker: *Wilmington* had very sleek lines, with a length between perpendiculars of 224

feet and a molded beam of 34 feet. An overall length of 233 feet 4 inches, extreme beam of 41 feet, depth of hold of 12 feet, and draft of 9.5 feet resulted in an ironclad not only very different from the *Richmond*-class vessels, but superiorly adapted to its operating environment (Holcombe 1993:130). A high design speed and low, rakish appearance with twin single-gun casemates only adds to the hypothesis that "...*Wilmington* was to be used for other than harbor defense purposes" (Holcombe 1993:127-130). A severe lack of iron for armor at that late stage of the war certainly cannot alone explain these sleek design features.

The engineering diagram showing this ironclad's high-speed machinery is also quite informative. *Wilmington*'s power plant was built by the Columbus Naval Iron Works but never delivered (National Archives RG 56: Case File 825). The ironclad was to be equipped with 4 triple-furnace boilers approximately 16 feet long, 6.5 feet high, and 8 feet wide powering 2 high-pressure single-cylinder horizontal engines 28 inches in bore, 24 inches in stroke, and placed fore and aft in the hull. Each engine was connected to the propeller shafts by 2 gears, one 4.5 feet and one 3 feet in diameter, which allowed for potentially greater speed through higher revolutions (Holcombe 1993:130). Twin eight-foot diameter propellers were prevented from independent maneuvering by the use of an idler shaft. The reasoning behind this design handicap is unknown.

The engines and boilers of *Wilmington* never left Columbus and were captured in April 1865 (National Archives RG 56: Case File 825). In many ways it is a shame that this ironclad and other late-war designs were never completed because not only did they reflect significant design improvements, but their purpose-built machinery should have been among the best built by either side at that late stage of the war. *Wilmington* perhaps emphasizes best of all the incredible growth and development of Confederate naval industry during the Civil War and at the same time that system's failure.

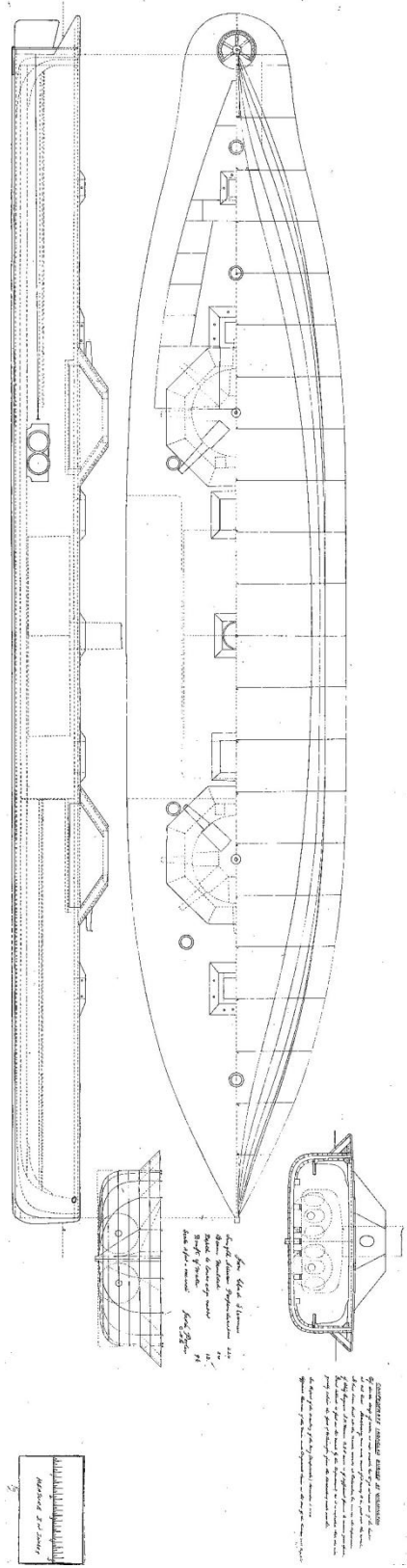

FIGURE VI.70. Porter's plans of *Wilmington*, showing hull construction and some engineering detail. (Courtesy of Robert Holcombe 2012)

Conclusions

The preceding pages have compiled for the first time most relevant available data on Confederate ironclad steam engines and propulsion systems. Hopefully, this will lead the way for further studies. More data may become available to fill the existing gaps as new documents are discovered or funding and time appropriated for archaeological surveys of the many remaining ironclad wrecks. In the meantime, the information presented has revealed the three main types of engine installed on Confederate ironclads: inverted vertical single-cylinder direct-acting models taken from tugs, inclined single-cylinder high-pressure direct-acting models taken from river steamers, and purpose-built horizontal single-cylinder direct-acting engines. It has been seen that the latter, most of which were made in Columbus, Georgia, generally proved superior.

CHAPTER 7: CONCLUSIONS

The general failure of the Confederate Navy to effectively construct quality marine steam machinery until war's end played an important role in the outcome of its shipbuilding programs. The ironclad program was the most important of these in resources allocated and sheer numbers. By 1865, approximately 50 ironclads had been laid down or contracted for, and of these 23 were placed into service (Still 1985:227). These numbers far exceeded those of the wooden gunboats and other small craft actually constructed (as compared to the vast numbers initially intended) in the early years of the war. As a result, the ironclads demanded a huge amount of material and technical knowhow that was often not available in time or of usable quantity. It is all the more remarkable, then, to consider the fact that any suitable steam machinery was obtained and that Secretary Mallory's program achieved as much as it did.

A significant lack of experience in machinery manufacturing was just one of many hurdles Mallory and the fledgling Confederate Navy had to overcome in 1861. It is remarkable that the South started with essentially nothing but a set of experienced officers resigned from the Union Navy, but had pioneered the organizational and technical basis of a modern navy by 1865. This included not only an ironclad fleet, but also mine, submarine, and commerce raiding warfare. All of these elements reflected the revolutionary new nature of war at sea (Luraghi 1996:346). Several Southern industries greatly scaled up production and achieved significant successes in heavy industrial manufacturing in order to provide these modern weapons to the Confederate cause. The Tredegar Iron Works, Shockoe Foundry (later the Confederate Naval Works), Charlotte Navy Yard, and Columbus Naval Iron Works were the greatest among these. The latter especially contributed to the manufacture of steam machinery in the Confederacy, and by war's end several complete and well-built sets had been delivered for installation in ironclads.

The various sets of machinery supplied to the Confederate ironclads ultimately reflected a combination of sources. Single-cylinder vertical inverted direct-acting tugboat engines, high-pressure inclined riverboat systems, and horizontal single-cylinder direct-acting engines were the three most important groups utilized. The purpose-built specimens represented by the horizontal direct-acting type were overwhelmingly the best of these. This was largely due to the simple fact that each set of new engines was specifically intended for a certain ironclad from the outset, and also as a result of refinements in manufacture during the war years. The secondhand power plants were usually unsatisfactory, although it appears that many of the scavenged riverboat systems such as those on *Missouri* and *Tennessee* performed surprisingly well.

Many ironclads, especially those of the *Richmond*-class, utilized former tugboat engines. These were often the most temperamental sets of machinery due to hard usage, age, and overstressed working when placed in a heavy ironclad. Those vessels so equipped were invariably underpowered. This was not necessarily a crippling problem, as virtually all the Confederate ironclads built after 1862 were intended for harbor defense (Still 1985:228). Lack of speed did render ramming more difficult in many cases, perhaps best emphasized by the January 1863 sortie of *Chicora* and *Palmetto State* from Charleston Harbor. In at least one case, that of *North Carolina*, a weak engine indirectly resulted in sinking by shipworm damage. Often the purpose-built boilers and auxiliary equipment manufactured by local industry were the best part of the power plants of the ironclads equipped with tug engines.

Civil War-era steam boilers came in a variety of types like the engines they powered, but onboard the Confederate ironclads the most common were the low-pressure horizontal “Scotch” firetube type and the Western rivers-style horizontal high-pressure flue type. Both were ideally suited to their purpose, although the high-pressure type was generally more prone to explosion.

Boilers were fairly easy to maintain or build unlike steam engines and the Confederates had no problem in procuring them for ironclads. Several local firms in Wilmington, Charleston, Savannah, and elsewhere had the capability of producing even the newer designs, rendering effective construction times and local deliveries. As a whole, the boilers and auxiliary equipment of the Confederate ironclads were standard for the day and much less troublesome to manufacture and operate than the engines.

Propellers and paddlewheel propulsion existed simultaneously by the Civil War, sometimes even on the same ship (such as *Louisiana*). Propellers had only just begun to supersede paddlewheels, and only then mostly on oceangoing vessels. Despite its seemingly-vulnerable and antiquated form, the paddlewheel continued to be a viable and effective means of propelling shallow-draft coastal and riparian vessels well into the 20th century. As regards the Confederate ironclads, no truly effective comparison can be made between those vessels fitted with paddlewheels and those with propellers due to differences in construction and operating environment, and the general prevalence of screw propeller designs. In fact, the only ironclads driven by paddlewheels that were finished (*Baltic*, *Louisiana*, *Missouri*, and *Nashville*) reflected different operating philosophies and layouts. Of the paddlewheel ironclads, *Baltic* and *Nashville* were sidewheelers and *Louisiana* and *Missouri* were centerwheelers. Only *Missouri* can be considered as somewhat of a success out of these. This was largely a result of design rather than engine type, as the Western riverboat-style power plants provided for these vessels generally functioned well even under the strain of guns and armor.

The vast majority of the Confederate ironclads were screw-propelled. This was mostly a result of the desire to protect the ship's drive system from battle damage and ramming. As emphasized spectacularly by *Nashville*, paddlewheels, especially sidewheels, were not suited for

coupling to the angled casemate and often resulted in vessels too large to effectively move themselves or support their own weight. The submerged, recessed nature of the propeller allowed for greater protection, although its more complicated emplacement and machinery connections often caused trouble in those early days of steam propulsion. In addition, the use of twin propellers on shallow draft designs like *Albemarle* potentially allowed for greater maneuvering ability. Often this layout was handicapped for unknown reasons by complicated gearing or coupling to prevent independent turning of the screws. Propellers were also more difficult to manufacture and maintain than paddlewheels but no significant problems in this area seem to have been encountered, even with ironclads operating in extremely shallow water such as *Neuse*.

It has been commonly emphasized since the Civil War that all Southern ironclads were inherently defective. This is not true—while their machinery often left much to be desired, the Confederate ironclads were strongly-built and adequately (most of the time, anyway) armed. Even the use of green wood in many cases did not negate their strength in battle; for example, *Louisiana* withstood the heavy guns of Farragut's fleet with only superficial damage and *Arkansas* was able to survive the gauntlet of the combined Union fleets above Vicksburg. It must be remembered that Union officers often made every effort to capture a Confederate ironclad when possible. Two, *Tennessee* and *Atlanta*, served effectively later in the war as Union vessels.

This thesis has resulted in a compilation of data on 27 Confederate ironclads and their steam machinery—23 finished and 4 nearly finished. It has put together for the first time detailed descriptions of machinery types commonly used on ironclads of the Civil War and afforded a view of those vessels in action. The firsthand engineering accounts from Confederate officers have proven to be quite rare and represent only a handful of ironclads, but offer an invaluable insight into the lives and dedication of these early steam pioneers. Without their services, which

in the agrarian Confederacy were scarce to begin with, Mallory's new state-of-the-art steam navy could not have functioned. The testimony of these men also offers valuable insight into the defects of their charges and aids in a final summation.

Trends in building and purchasing marine steam machinery, and also the testimony of engineers, have been clearly revealed by this thesis. Only one large gap remains—a conclusive appraisal of Confederate Engineer-in-Chief William P. Williamson's career and contributions. Unfortunately, this may never be possible due to the dearth of information relating to his work. The overall conclusions have not changed regarding Confederate marine steam machinery, particularly onboard ironclads, and this study has only corroborated them. The final summation is best made by Dr. William N. Still, Jr., author of the landmark *Iron Afloat: The Story of the Confederate Armorclads* (1985:102-104):

Of all aspects of the Confederate shipbuilding program, the marine engineering industry was by far the most backward, as it was in the United States as a whole. There was little scientific study of engineering before the war; construction of marine engines was frequently by rule of thumb. This was true throughout the war, in the North as well as in the South. All parts were generally made by hand, and although the concept of interchangeable parts for engines was quite common in the arms industry, it had not reached the marine engineering industry. In a field where all knowledge was empirical, it was inevitable that the Confederacy's first engines and other machinery would be inefficient. Nevertheless, Confederate marine engines, like the vessels themselves, improved with time, and by the end of the war a few satisfactory engines were being produced.

Credit for this was due to the dedication and drive of the men in charge of the Southern industries and their leadership in Navy Secretary Mallory. They made incredible gains in the face of overwhelming odds to not only industrialize during wartime, but to render a navy from scratch. Although the Confederate Navy and its ironclads played mostly a defensive role, several major ports such as Wilmington, Charleston, and Mobile were kept open until nearly war's end by the presence of steam-powered armored vessels. Thus the crucible of war in the United States

paved the way for the birth of a modern navy: steam-powered sail-less warships, mines, submarines, and commerce raiding; all hallmarks of those great naval actions beginning half a century later in the First World War. It is remarkable to consider the fact that an agrarian nation was able to make such gains in four short years and just as remarkable that the North was able to improve upon and counter these gains, leading to an explosion of new technical developments at sea. Just 20 short years after the Civil War these continuing developments allowed the United States Navy to compete successfully on the world stage for the first time with the launch and shakedown of its first modern seagoing armored cruisers.

Although it is not widely appreciated today, or even was in its own time, the Confederate Navy was responsible in large part for many new technical developments. The ironclad program is probably the best-known of these. Secretary Mallory's vision allowed for the creation of what may be tentatively labeled the first "all-modern" navy. The Confederate Navy represented an impressive achievement, especially in the development of the naval-industrial complex and marine machinery manufacture, despite lasting only four years. These facts were certainly not lost on Mallory, who despite his deficiencies can be considered a visionary and the South's best man for the job (Luraghi 1996:10). The final statement on the Confederate Navy is in his words:

I am satisfied that, with the means at our control and in view of the overwhelming force of the enemy at the outset of the struggle, our little navy accomplished more than could have been looked or hoped for; and if I have ever felt any surprise connected with its operations, it was that we accomplished so much. (Still 1985:227, from James H. Rochelle Papers, Duke University)

APPENDIX A: CONFEDERATE IRONCLAD STEAM MACHINERY SPECIFICATIONS

Conversions

CSS *Manassas* (ex-*Enoch Train*).....un-surveyed archaeological resource

- ❖ Engine Type: 2 single-cylinder inclined direct-acting
Engine Dimensions: 36-inch diameter x 34-inch stroke
Engine Builder: Loring’s City Point Works, Boston, MA
Engine Notes: low-pressure, condensing
- ❖ Boiler Type: 1 or 2 horizontal
Boiler Dimensions: unknown
Boiler Builder: Loring’s City Point Works, Boston, MA
Boiler Notes: low-pressure
- ❖ Propulsion System: 2 propellers, 9-foot diameter
Propulsion System Builder: Loring’s City Point Works, Boston, MA
Propulsion System Notes: independently turning

CSS *Virginia* (ex-USS *Merrimack*).....un-surveyed archaeological resource

- ❖ Engine Type: 2 single-cylinder horizontal return piston rod (“back-acting”)
Engine Dimensions: 72-inch diameter x 36-inch stroke
Engine Builder: West Point Foundry, Cold Springs, NY
Engine Notes: low-pressure, condensing
- ❖ Boiler Type: 4 Martin vertical watertube, 3 furnaces each
Boiler Dimensions: 15 feet high, 14 feet wide, 12 feet long
Boiler Builder: West Point Foundry, Cold Springs, NY
Boiler Notes: low-pressure
- ❖ Propulsion System: 1 propeller, 17-foot 4-inch diameter
Propulsion System Builder: West Point Foundry, Cold Springs, NY
Propulsion System Notes: Griffiths-patent propeller with variable pitch

CSS *Baltic*.....scrapped postwar

- ❖ Engine Type: 2 single-cylinder inclined direct-acting
Engine Dimensions: 22-inch diameter x 7-foot stroke
Engine Builder: unknown
Engine Notes: high-pressure, standard Western river type
- ❖ Boiler Type: 4 horizontal return flue
Boiler Dimensions: 24 feet long x 3 feet diameter
Boiler Builder: unknown
Boiler Notes: high-pressure, standard Western river type

- ❖ Propulsion System: 2 sidewheels, 29 feet diameter x 8 feet wide
 Propulsion System Builder: unknown
 Propulsion System Notes: independently turning

Early Non-standard Types

CSS *Arkansas*.....un-surveyed archaeological resource

- ❖ Engine Type: 2 single-cylinder horizontal direct-acting
 Engine Dimensions: 30-inch diameter x 30-inch stroke
 Engine Builder: Union Foundry & Machine Shop or S.M. Coates foundry, Memphis, TN
 Engine Notes: high-pressure, non-condensing
- ❖ Boiler Type: 6 horizontal
 Boiler Dimensions: unknown
 Boiler Builder: Union Foundry & Machine Shop or S.M. Coates foundry, Memphis, TN
 Boiler Notes: high-pressure
- ❖ Propulsion System: 2 propellers, 8-foot diameter
 Propulsion System Builder: Leeds & Co., New Orleans, LA
 Propulsion System Notes: independently turning

CSS *Louisiana*.....un-surveyed archaeological resource

- ❖ Engine Type: 2 single-cylinder inclined direct-acting, 2 unknown
 Engine Dimensions: 28-inch diameter x 7-foot stroke, propeller engines unknown
 Engine Builder (paddlewheel): Roach & Long, Louisville, KY
 Engine Builder (propeller): Kirk & Co., New Orleans, LA
 Engine Notes: high-pressure paddlewheel engines taken from river steamboat *Ingomar*
- ❖ Boiler Type: 6 horizontal return flue
 Boiler Dimensions: unknown
 Boiler Builder: unknown
 Boiler Notes: high-pressure, taken from river steamboat *Ingomar*
- ❖ Primary Propulsion System: 2 centerwheels, 27 feet diameter x 19 feet wide
 Secondary Propulsion System: 2 propellers, 4-foot diameter
 Primary Propulsion System Builder: E.C. Murray, Jefferson City, LA
 Secondary Propulsion System Builder: Kirk & Co., New Orleans, LA
 Propulsion System Notes: completely ineffectual

CSS *Georgia*.....extensively surveyed archaeological resource, plans for conservation

- ❖ Engine Type: 2 single-cylinder horizontal direct-acting
 Engine Dimensions: 24-inch diameter x 39.5-inch stroke
 Engine Builder: probably Alvin N. Miller foundry, Savannah, GA
 Engine Notes: low-pressure, condensing

- ❖ Boiler Type: 1 or 2 horizontal firetube
Boiler Dimensions: approximately 18 feet long x 7.5 feet wide
Boiler Builder: probably Alvin N. Miller foundry, Savannah, GA
Boiler Notes: low-pressure, standard marine variant of locomotive boiler
- ❖ Propulsion System: 2 propellers, 8-foot diameter
Propulsion System Builder: probably Alvin N. Miller foundry, Savannah, GA
Propulsion System Notes: completely ineffectual

Richmond-class Vessels

CSS *Richmond*.....partially surveyed archaeological resource

- ❖ Engine Type: 1 single-cylinder vertical inverted direct-acting
Engine Dimensions: unknown
Engine Builder: probably Reaney, Neafie & Co., Penn Works, Philadelphia, PA
Engine Notes: taken from steamer CSS *Arctic* (ex-USS *Arctic*, ex-*Lightship No. 8*)
- ❖ Boiler Type: 2 horizontal “Scotch” firetube
Boiler Dimensions: approximately 10 feet long, 11 feet high, 6 feet 9 inches wide
Boiler Builder: Tredegar Iron Works or Shockoe Foundry, Richmond, VA
Boiler Notes: low-pressure
- ❖ Propulsion System: 1 propeller, 8 or 10-foot diameter
Propulsion System Builder: Tredegar Iron Works or Shockoe Foundry, Richmond, VA
Propulsion System Notes: standard single-propeller design

CSS *Chicora*.....partially surveyed archaeological resource

- ❖ Engine Type: 1 single-cylinder vertical inverted direct-acting
Engine Dimensions: 30-inch diameter x 28-inch stroke
Engine Builder: Reaney, Neafie & Co., Penn Works, Philadelphia, PA
Engine Notes: low-pressure, taken from steam tug *Aid*
- ❖ Boiler Type: 2 horizontal “Scotch” firetube
Boiler Dimensions: approximately 10 feet long, 11 feet high, 6 feet 9 inches wide
Boiler Builder: James M. Eason & Brother, Charleston, SC
Boiler Notes: low-pressure
- ❖ Propulsion System: 1 propeller, 8-foot diameter
Propulsion System Builder: James M. Eason & Brother, Charleston, SC
Propulsion System Notes: standard single-propeller design

CSS *Palmetto State*.....un-surveyed archaeological resource

- ❖ Engine Type: 2 single-cylinder horizontal direct-acting
Engine Dimensions: 30-inch diameter x 26-inch stroke

Engine Builder: Reaney, Neafie & Co., Penn Works, Philadelphia, PA
Engine Notes: low-pressure, taken from CSS *Lady Davis* (ex-steam tug *James Gray*)

- ❖ Boiler Type: 2 horizontal “Scotch” firetube
Boiler Dimensions: approximately 10 feet long, 11 feet high, 6 feet 9 inches wide
Boiler Builder: Cameron & Co., Charleston, SC
Boiler Notes: low-pressure
- ❖ Propulsion System: 1 propeller, 8 or 10-foot diameter
Propulsion System Builder: Cameron & Co., Charleston, SC
Propulsion System Notes: standard single-propeller design

CSS *North Carolina*.....partially surveyed archaeological resource

- ❖ Engine Type: 1 single-cylinder vertical inverted direct-acting
Engine Dimensions: unknown
Engine Builder: Bidwell and Banta, Buffalo, NY
Engine Notes: low-pressure, taken from steam tug *Uncle Ben*, weak and ineffectual
- ❖ Boiler Type: 2 horizontal “Scotch” firetube
Boiler Dimensions: approximately 10 feet long, 11 feet high, 6 feet 9 inches wide
Boiler Builder: Hart & Bailey Iron Works, Wilmington, NC
Boiler Notes: low-pressure
- ❖ Propulsion System: 1 propeller, 8 or 10-foot diameter
Propulsion System Builder: Hart & Bailey Iron Works, Wilmington, NC
Propulsion System Notes: standard single-propeller design

CSS *Raleigh*.....partially surveyed archaeological resource

- ❖ Engine Type: 2 single-cylinder horizontal direct-acting
Engine Dimensions: 24-inch diameter x 36-inch stroke
Engine Builder: Tredegar Iron Works or Shockoe Foundry, Richmond, VA
Engine Notes: probably from unfinished wooden gunboat at Washington, NC
- ❖ Boiler Type: 2 horizontal “Scotch” firetube
Boiler Dimensions: approximately 10 feet long, 11 feet high, 6 feet 9 inches wide
Boiler Builder: Clarendon Iron Works, Wilmington, NC
Boiler Notes: low-pressure
- ❖ Propulsion System: 1 propeller, 8 or 10-foot diameter
Propulsion System Builder: Clarendon Iron Works, Wilmington, NC
Propulsion System Notes: standard single-propeller design

CSS *Savannah*.....un-surveyed archaeological resource

- ❖ Engine Type: 2 single-cylinder horizontal direct-acting
Engine Dimensions: 28-inch bore (34.5 inch external diameter) x 20-inch stroke
Engine Builder: Columbus Naval Iron Works, Columbus, GA
Engine Notes: low-pressure, originally for unfinished wooden gunboat at Milton, FL
- ❖ Boiler Type: 2 horizontal “Scotch” firetube, 3 furnaces each
Boiler Dimensions: 11 feet 2 inches long, 12 feet high, 7 feet 10 inches wide
Boiler Builder: Columbus Naval Iron Works, Columbus, GA
Boiler Notes: low-pressure
- ❖ Propulsion System: 1 propeller, 8-foot diameter
Propulsion System Builder: Columbus Naval Iron Works, Columbus, GA
Propulsion System Notes: standard single-propeller design

Tennessee-class Vessels

CSS *Tennessee*.....scrapped postwar

- ❖ Engine Type: 2 adapted single-cylinder inclined direct-acting
Engine Dimensions: 24-inch diameter x 7-foot stroke
Engine Builder: unknown
Engine Notes: high-pressure, taken from river steamboat *Vicksburg*
- ❖ Boiler Type: 4 horizontal return flue, 1 furnace under all
Boiler Dimensions: 24 feet long, other dimensions unknown
Boiler Builder: unknown
Boiler Notes: high-pressure, taken from river steamboat *Vicksburg*
- ❖ Propulsion System: 1 propeller, 12-foot diameter
Propulsion System Builder: Charlotte Navy Yard, Charlotte, NC
Propulsion System Notes: geared to engines

CSS *Columbia*.....scrapped postwar

- ❖ Engine Type: 2 single-cylinder horizontal direct-acting
Engine Dimensions: 36-inch diameter x 24-inch stroke
Engine Builder: Columbus Naval Iron Works, Columbus, GA
Engine Notes: high-pressure, non-condensing
- ❖ Boiler Type: 5 horizontal return flue
Boiler Dimensions: 22 feet long x 4 feet diameter
Boiler Builder: Columbus Naval Iron Works, Columbus, GA
Boiler Notes: high-pressure
- ❖ Propulsion System: 1 propeller, 10 feet 8-inch diameter

Propulsion System Builder: Columbus Naval Iron Works, Columbus, GA
Propulsion System Notes: standard single-propeller design

Vessels Designed by William Graves

CSS *Charleston*.....un-surveyed archaeological resource

- ❖ Engine Type: 1 or 2 unknown direct-acting types
Engine Dimensions: unknown
Engine Builder: probably J.M. Eason & Brother, Charleston, SC
Engine Notes: reportedly underpowered
- ❖ Boiler Type: unknown
Boiler Dimensions: unknown
Boiler Builder: probably J.M. Eason & Brother, Charleston, SC
Boiler Notes: probably low-pressure
- ❖ Propulsion System: 1 propeller, 9-foot diameter
Propulsion System Builder: probably J.M. Eason & Brother, Charleston, SC
Propulsion System Notes: standard single-propeller design

CSS *Virginia II*.....un-surveyed archaeological resource

- ❖ Engine Type: 2 single-cylinder horizontal or 2 British 2-cylinder compound
Engine Dimensions (if American): approximately 40-inch diameter x 38-inch stroke
Engine Dimensions (if British): unknown
Engine Builder (if American): Tredegar Iron Works or Shockoe Foundry, Richmond, VA
Engine Builder (if British): unknown
Engine Notes: referenced as having “nearly 800 horse[power]”
- ❖ Boiler Type: 2 horizontal firetube, 2 furnaces each
Boiler Dimensions: 22 feet long, 9 feet high, 8 feet wide
Boiler Builder: Tredegar Iron Works or Shockoe Foundry, Richmond, VA
Boiler Notes: probably low-pressure
- ❖ Propulsion System: 1 propeller, 10-foot diameter
Propulsion System Builder: Charlotte Navy Yard, Charlotte, NC
Propulsion System Notes: standard single-propeller design

Large Sidewheelers

CSS *Nashville*.....scrapped postwar

- ❖ Engine Type: 2 single-cylinder inclined direct-acting
Engine Dimensions: 30 or 32-inch diameter x 9-foot stroke
Engine Builder: unknown
Engine Notes: high-pressure, taken from river steamboats *Capitol* or *Magenta*

- ❖ Boiler Type: 7 horizontal return flue
Boiler Dimensions: 30 feet long x 40 or 42-inch diameter
Boiler Builder: unknown
Boiler Notes: high-pressure, taken from river steamboats *Capitol* or *Magenta*
- ❖ Propulsion System: 2 sidewheels, 28 feet diameter x 12 feet wide
Propulsion System Builder: J.E. Montgomery and A. Anderson, Montgomery, AL
Propulsion System Notes: independently turning

Diamond Hull Vessels

CSS *Tuscaloosa*.....partially surveyed archaeological resource

- ❖ Engine Type: 2 adapted single-cylinder inclined direct-acting
Engine Dimensions: unknown
Engine Builder: unknown
Engine Notes: high-pressure, taken from river steamboat *Chewala*
- ❖ Boiler Type: probably horizontal return flue
Boiler Dimensions: unknown
Boiler Builder: unknown
Boiler Notes: high-pressure, taken from river steamboat *Chewala*
- ❖ Propulsion System: 2 propellers, approximately 8-foot diameter
Propulsion System Builder: William Penny & Co., Prattville, AL
Propulsion System Notes: geared to engines, completely ineffectual

CSS *Huntsville*.....partially surveyed archaeological resource

- ❖ Engine Type: 2 adapted single-cylinder inclined direct-acting
Engine Dimensions: unknown, probably similar to *Tuscaloosa*
Engine Builder: unknown
Engine Notes: high-pressure, possibly taken from river steamboat *John C. Calhoun*
- ❖ Boiler Type: probably horizontal return flue
Boiler Dimensions: unknown, probably similar to *Tuscaloosa*
Boiler Builder: unknown
Boiler Notes: high-pressure, possibly taken from river steamboat *John C. Calhoun*
- ❖ Propulsion System: 2 propellers, approximately 8-foot diameter
Propulsion System Builder: Columbus Naval Iron Works, Columbus, GA
Propulsion System Notes: geared to engines, completely ineffectual

CSS *Albemarle*.....scrapped postwar

- ❖ Engine Type: 2 single-cylinder horizontal direct-acting
Engine Dimensions: 18-inch diameter x 19-inch stroke

Engine Builder: uncertain; possibly Tredegar Iron Works, Richmond, VA
Engine Notes: high-pressure, non-condensing, may have been scratch-built

- ❖ Boiler Type: 2 vertical watertube, 1 furnace each
Boiler Dimensions: 15 feet 4 inches long, 5 feet 2 inches high, 4 feet 7 inches wide
Boiler Builder: uncertain; possibly Tredegar Iron Works, Richmond, VA
Boiler Notes: high-pressure, may have been scratch-built
- ❖ Propulsion System: 2 propellers, 6-foot diameter
Propulsion System Builder: Charlotte Navy Yard, Charlotte, NC
Propulsion System Notes: geared to engines

CSS *Neuse*.....raised and preserved, on display at Kinston, NC

- ❖ Engine Type: 2 single-cylinder horizontal direct-acting
Engine Dimensions: probably 17-inch diameter x 24-inch stroke
Engine Builder: probably Baltimore & Ohio Railroad
Engine Notes: high-pressure, probably taken from B. & O. locomotive # 34 “Gladiator”
- ❖ Boiler Type: 1 horizontal firetube, 1 furnace
Boiler Dimensions: 15 feet long, other dimensions unknown
Boiler Builder: Baltimore & Ohio Railroad
Boiler Notes: taken from B. & O. locomotive # 34 “Gladiator”
- ❖ Propulsion System: 2 propellers, 6-foot diameter
Propulsion System Builder: unknown
Propulsion System Notes: geared to engines

CSS *Fredericksburg*.....un-surveyed archaeological resource

- ❖ Engine Type: 2 single-cylinder horizontal direct-acting
Engine Dimensions: 24-inch diameter, other dimensions unknown
Engine Builder: Tredegar Iron Works or Shockoe Foundry, Richmond, VA
Engine Notes: probably high-pressure
- ❖ Boiler Type: 3 horizontal
Boiler Dimensions: approximately 15 feet long, 7 feet high, 5 feet diameter
Boiler Builder: Tredegar Iron Works or Shockoe Foundry, Richmond, VA
Boiler Notes: probably high-pressure
- ❖ Propulsion System: 2 propellers, 7-foot diameter
Propulsion System Builder: Tredegar Iron Works or Shockoe Foundry, Richmond, VA
Propulsion System Notes: unknown method of connection with engines

CSS *Missouri*.....scrapped postwar

- ❖ Engine Type: 2 single-cylinder inclined direct-acting
Engine Dimensions: 24-inch diameter x 7.5-foot stroke
Engine Builder: unknown
Engine Notes: high-pressure, taken from river steamboats *Grand Era* or *T.W. Roberts*
- ❖ Boiler Type: 4 horizontal return flue
Boiler Dimensions: 26 feet long x 40-inch diameter
Boiler Builder: unknown
Boiler Notes: high-pressure, taken from river steamboats *Grand Era* or *T.W. Roberts*
- ❖ Propulsion System: 1 centerwheel, 22.5 feet diameter x 17 feet wide
Propulsion System Builder: probably Thomas Moore and John Smoker
Propulsion System Notes: similar to Union “City-class” ironclad gunboats

Uncompleted Vessels (>50% complete)

CSS *Mississippi*.....partially-destroyed remains scrapped 1862

- ❖ Engine Type: 3 single-cylinder horizontal direct-acting
Engine Dimensions: 30-inch bore x 36-inch stroke
Engine Builder: Patterson Iron Works (Jackson & Co.), New Orleans, LA
Engine Notes: high-pressure
- ❖ Boiler Type: 16 horizontal return flue
Boiler Dimensions: 30 feet long x 42-inch diameter
Boiler Builder: Patterson Iron Works (Jackson & Co.), New Orleans, LA
Boiler Notes: high-pressure, capable of approximately 1,500 horsepower
- ❖ Propulsion System: 3 propellers, 11-foot diameter
Propulsion System Builder (center shaft): Tredegar Iron Works, Richmond, VA
Propulsion System Builder (wing shafts): Clark & Co., New Orleans, LA
Propulsion System Notes: one of first triple-screw systems designed

CSS *Jackson*.....raised and preserved, on display at Columbus, GA

Original Design

- ❖ Engine Type: 2 single-cylinder inclined direct-acting
Engine Dimensions: 30-inch diameter, other dimensions unknown
Engine Builder: unknown
Engine Notes: high-pressure, taken from river steamboat *Time*
- ❖ Boiler Type: 4 horizontal return flue
Boiler Dimensions: unknown
Boiler Builder: unknown
Boiler Notes: high-pressure, taken from river steamboat *Time*

- ❖ Propulsion System: 1 centerwheel, approximately 20 feet diameter x 20 feet wide
 Propulsion System Builder: Columbus Naval Iron Works, Columbus, GA
 Propulsion System Notes: similar to *Missouri*

Final Design

- ❖ Engine Type: 2 single-cylinder horizontal direct-acting
 Engine Dimensions: 36-inch bore x 36-inch stroke
 Engine Builder: Columbus Naval Iron Works, Columbus, GA
 Engine Notes: high-pressure
- ❖ Boiler Type: 4 horizontal return flue
 Boiler Dimensions: unknown
 Boiler Builder: unknown
 Boiler Notes: high-pressure, retained from original design
- ❖ Propulsion System: 2 propellers, 7.5-foot diameter
 Propulsion System Builder: Columbus Naval Iron Works, Columbus, GA
 Propulsion System Notes: independently turning

CSS *Milledgeville*.....un-surveyed archaeological resource

- ❖ Engine Type: 2 single-cylinder horizontal direct-acting
 Engine Dimensions: approximately 30-inch diameter, other dimensions unknown
 Engine Builder: Columbus Naval Iron Works, Columbus, GA
 Engine Notes: probably low-pressure, similar to *Columbia*
- ❖ Boiler Type: 2 horizontal
 Boiler Dimensions: 14 feet long x 6 feet diameter
 Boiler Builder: Columbus Naval Iron Works, Columbus, GA
 Boiler Notes: probably low-pressure
- ❖ Propulsion System: 2 propellers, 7-foot diameter
 Propulsion System Builder: Columbus Naval Iron Works, Columbus, GA
 Propulsion System Notes: unknown method of connection with engines

CSS *Wilmington*.....burned on stocks 1865

- ❖ Engine Type: 2 single-cylinder horizontal direct-acting
 Engine Dimensions: 28-inch bore x 24-inch stroke
 Engine Builder: Columbus Naval Iron Works, Columbus, GA
 Engine Notes: high-pressure
- ❖ Boiler Type: 4 horizontal, 3 furnaces each
 Boiler Dimensions: approximately 16 feet long, 6.5 feet high, 8 feet wide
 Boiler Builder: Columbus Naval Iron Works, Columbus, GA
 Boiler Notes: high-pressure

- ❖ Propulsion System: 2 propellers, 8-foot diameter
Propulsion System Builder: Columbus Naval Iron Works, Columbus, GA
Propulsion System Notes: geared to engines

APPENDIX B: AUXILIARY EQUIPMENT

An obscure but vital part of any steamship's power plant is the auxiliaries; as Alan Bates writes on page 53 of his 1996 work *The Western Rivers Engineroom Cyclopoedium*: "Every transportation vehicle must do more than move." Everything from automobiles to steamships must have auxiliary systems that run off the main engine to do any number of lesser tasks. Especially onboard ships these duties revolve mostly around pumping. There were a number of auxiliary systems in use on steam vessels during the Civil War era, but they remained highly non-standardized for many years. This more often than not reflected the business practices of the Western rivers, where the adoption of new technology was often seen as unnecessary. Nevertheless, by the 1860s important advancements had been made.

There were some important differences in auxiliary equipment between riverboats and oceangoing vessels. The latter, including warships, utilized low-pressure engines. These lent themselves to a process termed condensing which allowed for the exhaust steam from the engines to be recycled into water and returned to the boilers via a small reservoir and filter called the "hot well." This was an important function on oceangoing steamships without a constant supply of freshwater for the boilers, and condensers often took up a great deal of space in the engine room. Condensers were rare onboard high-pressure riverboats, which instead simply filtered boiler water from fresh river water.

The most common type of condenser up to the 1870s was the jet. It worked by mixing a jet of cold water with the exhaust steam, condensing the water and creating a vacuum, which allowed for pumping into the hot well. Jet condensation had no real competition until the 1830s with the development of the closed (or surface) condenser by Samuel Hall (Smith 1937:153). Surface condensing worked as a sort of "reverse" boiler: cold water tubes were surrounded by

exhaust steam. As the steam cooled it created a partial vacuum which allowed for pumping and removal of air (Bates 1996:20). Both condenser types were considerably less common on American rivers, but did see use when there was assurance of deep, relatively clean water. The surface condenser came to be the preferred type. Figure B.1 shows both condensers.

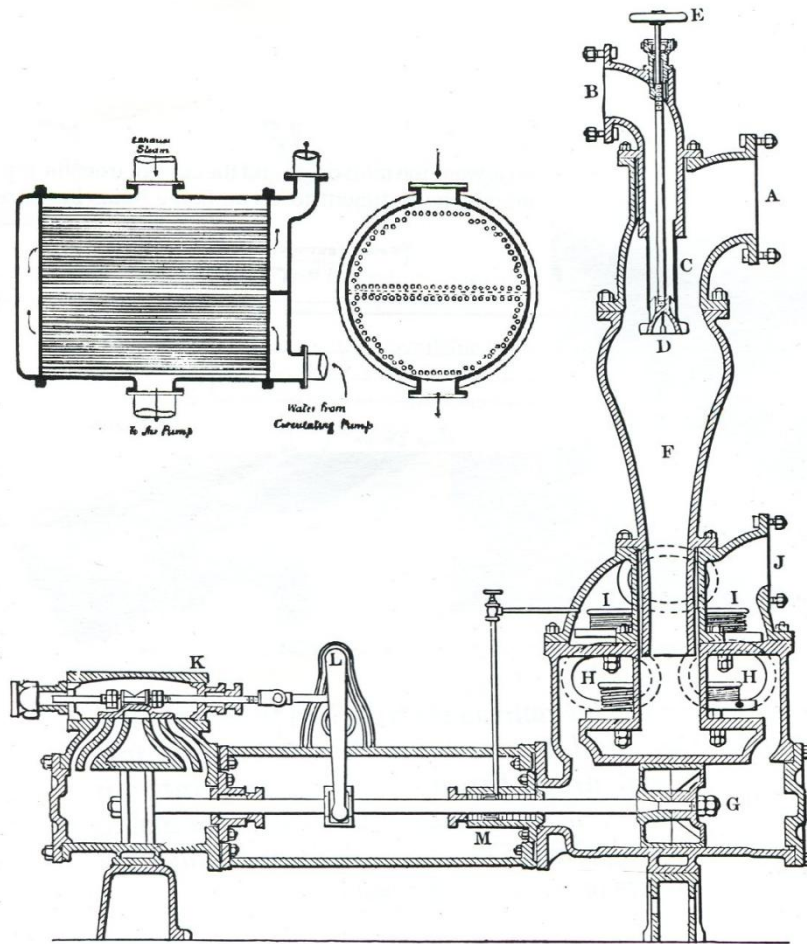

FIGURE B.1. Upper left: cross-section of a typical surface, or closed, condenser. Lower right: cross-section of a typical jet condenser. (Adapted from Bates 1996:20-21)

Other auxiliary equipment was common onboard both riverboats and blue water vessels. By the Civil War, systems had been introduced for powering capstans, fan blowers, bilge pumps, firefighting equipment, and boiler feedwater devices. The steam whistle had also been introduced on the rivers in the 1840s, but is not known to have been used on any Confederate ironclad. The other systems listed were common by the 1860s but any one ship did not necessarily have all of

them. Fan blowers in particular were a recent innovation. In this system a small vertical boiler, usually called a “donkey”, coupled to a small engine turned a fan or fans placed in the smokebox, the entrance to the funnel(s). This created a forced draft for the boiler fires. Only three Southern ironclads, *Atlanta*, *Tennessee*, and *Missouri*, are known to have used this system. Forced draft fans never became common during the Civil War because of scarcity of materials for them, excessive wear, and the common belief that natural draft was better.

Donkey boilers, seen in Figure B.2, and their engines could be used to power other auxiliaries such as steam capstans. This arrangement was not common on warships because of the abundance of manpower but at least one ironclad, CSS *Missouri*, had it. Steam-driven capstans were considerably more abundant onboard sailing merchantmen, which had small crews for economical reasons. A diagram of this system is shown in Figure B.3.

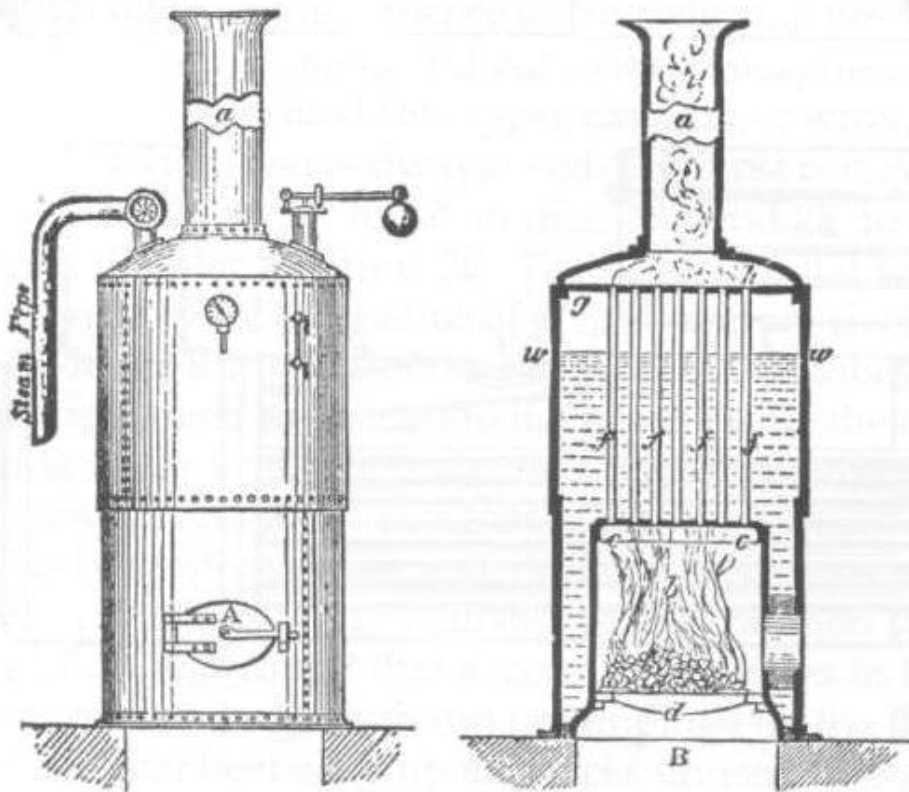

FIGURE B.2. Profile and cutaway of typical small vertical firetube boiler, or “donkey” (Bates 1996:12)

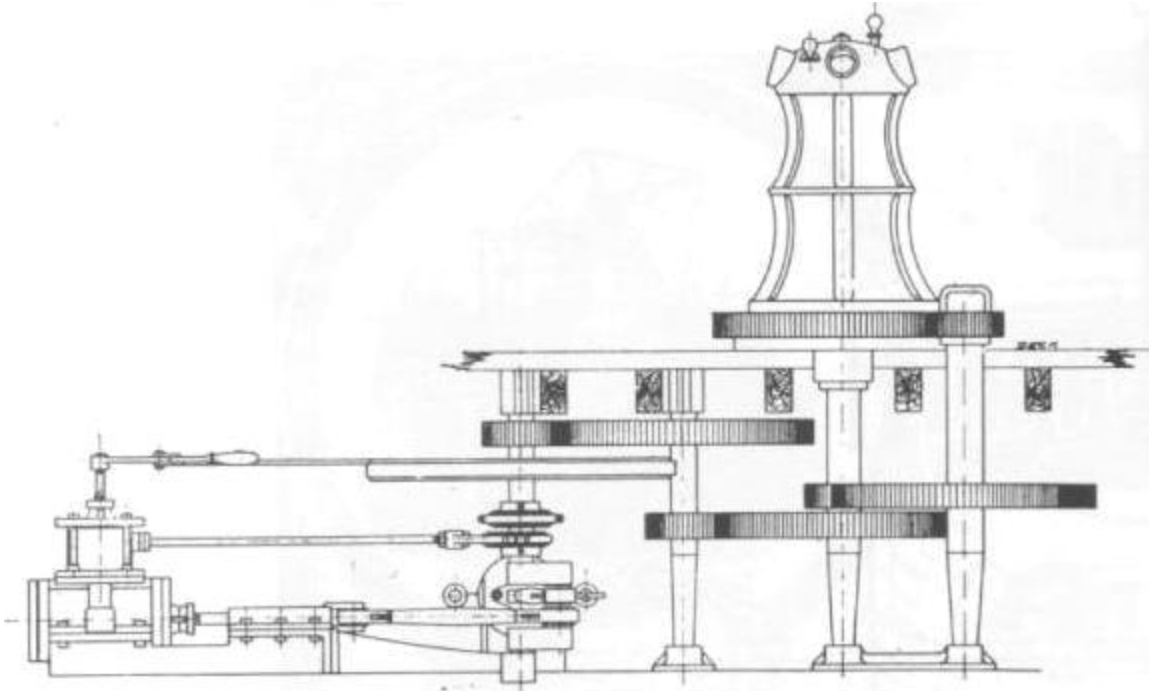

FIGURE B.3. Steam-driven capstan with horizontal below-deck engine, similar to that onboard *CSS Missouri* (Bates 1996:54)

The rest of the auxiliary machinery carried onboard steamships during the 1860s related to boiler feedwater and pumping. Pumping duties not directly connected with the boilers were absorbed by the hand-powered main force pump, seen in Figure B.4. Every vessel had at least one of these placed near the boilers. In the early days before steam pumps were common onboard ship, the main force pump was used for filling the boilers, making hydrostatic tests, and emptying the bilges. As can be imagined, this was time-consuming and strenuous work, but even when more automated systems came along the manual pumps were retained as backup.

Vessels were fitted with improved and powerful pumps driven by steam beginning in the 1860s. Probably the best of these was that invented by Henry Worthington. His design was a compact single-cylinder “simplex” pump in which the steam and water pistons were attached to the same rod (Bates 1996:16). A larger duplex pump was also developed by Worthington and saw widespread use onboard larger vessels. Figure B.5 shows both Worthington pumps.

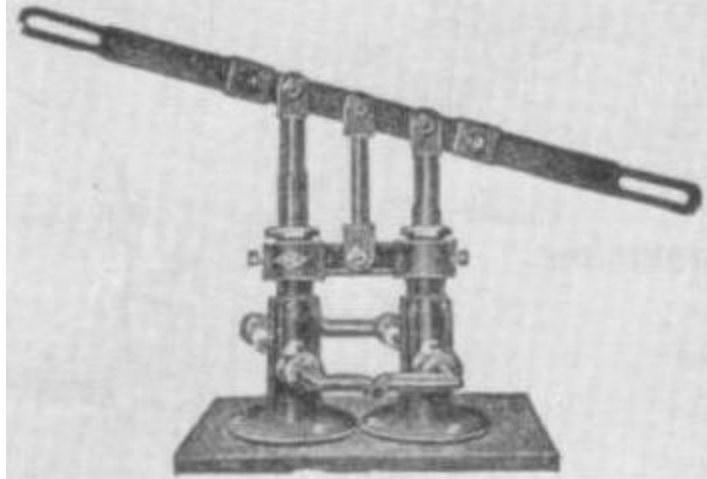

FIGURE B.4. Typical main force pump. Wooden cross-handles are fitted in time of use. (Bates 1996:25)

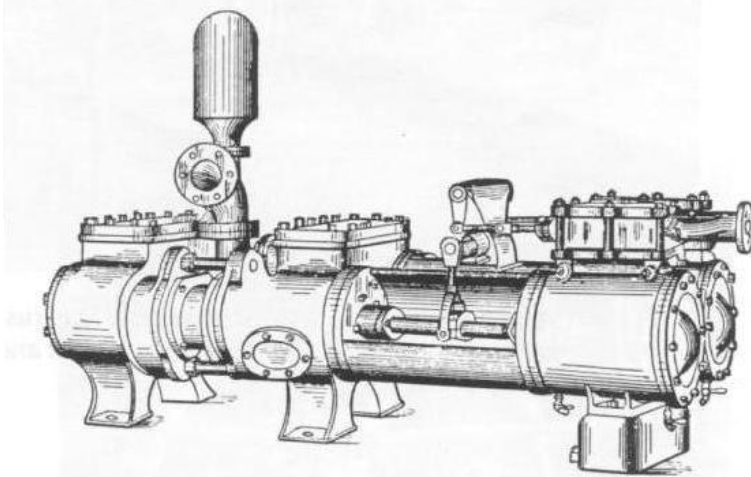
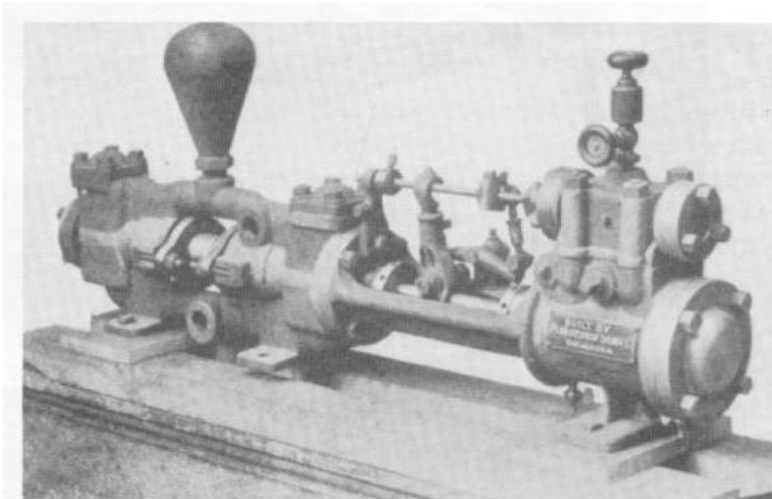

FIGURE B.5. Top: photograph of Worthington simplex (single-cylinder) pump. Bottom: Drawing of Worthington duplex (two-cylinder) pump. The balloon-shaped extensions are air expansion chambers. (Adapted from Bates 1996:16)

The final sets of auxiliaries in common use by the Civil War were related to boiler feedwater. As Bates 1996:13 states:

Boilers absorb the work of a lot of machinery that has nothing to do with propelling the boat. The most vital of these is the feedwater system, for without water there can be no steam. Too little water can result in a disastrous explosion. To prevent that, steamboats are required to have more than one feedwater system.

The earliest steamships had pumps that ran directly off the main propelling engine. While simple and effective when the vessel was in operation, no water could be supplied when the engines were stopped. This caused many explosions. Beginning in the late 1830s the “doctor” engine became common. It got its name because it “cured” the ills of the previous system. A doctor engine was simply a small vertical walking beam type of one or two cylinders attached to pumps (Figure B.6). This arrangement was efficiently used for supplying the boilers, supplying firefighting water, and pumping the bilges. Doctors were equipped with at least one feedwater heater which heated the water before returning it to the boilers, lessening the chances of cold shock and explosion. Figure B.7 shows a typical closed feedwater heater.

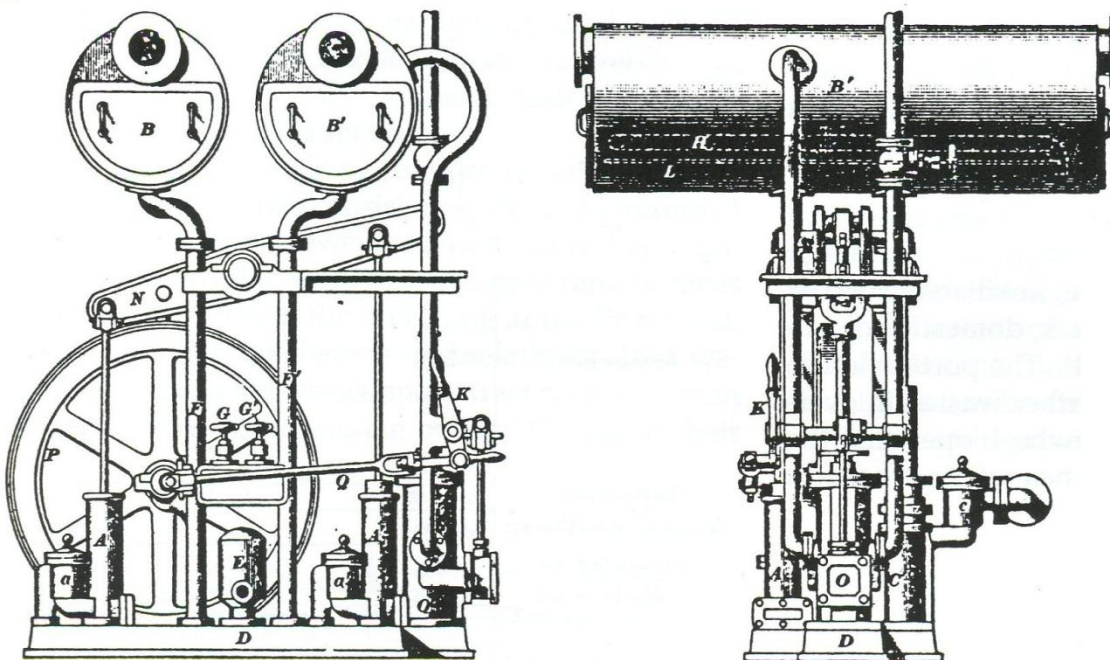

FIGURE B.6. Typical doctor engine with two feedwater heaters (Bates 1996:14)

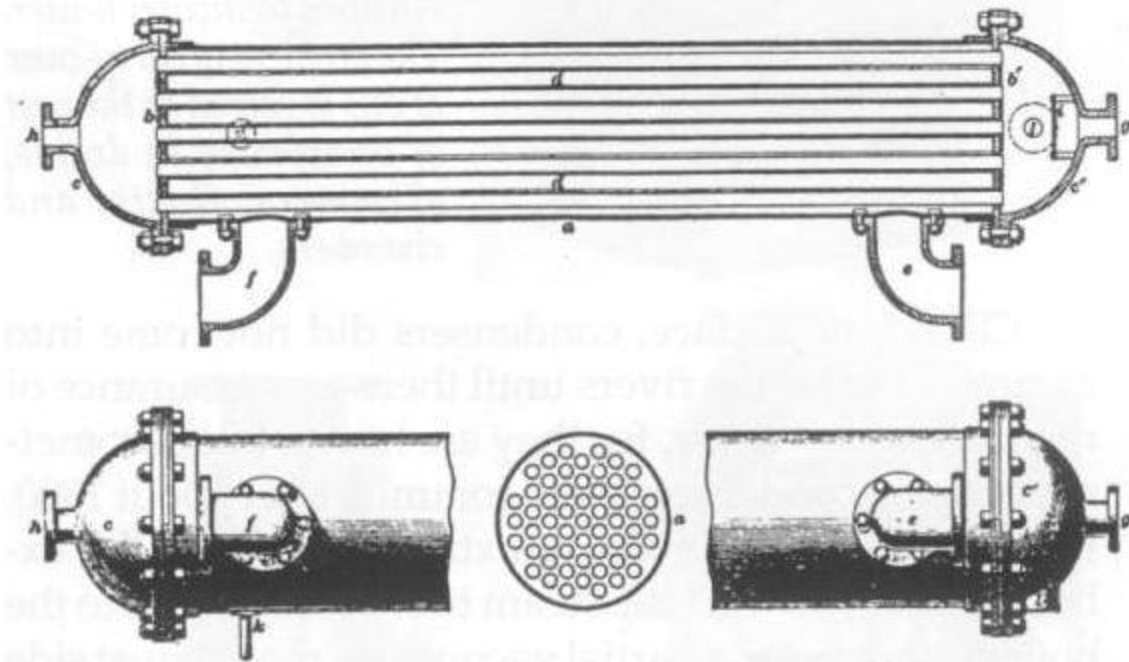

FIGURE B.7. Typical closed feedwater heater (Bates 1996:19)

A final important piece auxiliary equipment connected with the boilers was the live steam injector, first invented by M.H. Gifford in the 1850s (Bates 1996:15). This elegantly simple device augmented the doctor engine as a feedwater supply, contained no moving parts, and was compact and cheap. Injectors worked by firing a steam jet through a Venturi tube in the feedwater line. Sufficient velocity was therefore created to drive the mix into the boiler. The water-steam mixture was effectively introduced at high pressure and temperature like that inside the boiler. This efficient system is shown in Figure B.8.

Aside from other small components such as gauge cocks for determining boiler water levels, simple lever safety valves, and hydrostatic lubricators for supplying cylinder oil (Figure B.9), auxiliary systems onboard 1850s-1860s steam vessels were primarily concerned with pumping and feedwater supply tasks. This was also the case on ironclad warships. Often, the arrangement of these systems only added to the great complexity of the steam power plant. The early days of a simple layout of boilers, engines, and manual pumps were long gone by the

1860s. Steam propulsion was quickly becoming the amazingly complex, powerful, and reliable mode of power generation utilized until the mid-20th century. In the midst of all this progress, auxiliary systems continued to perform their important but obscure role in steam navigation.

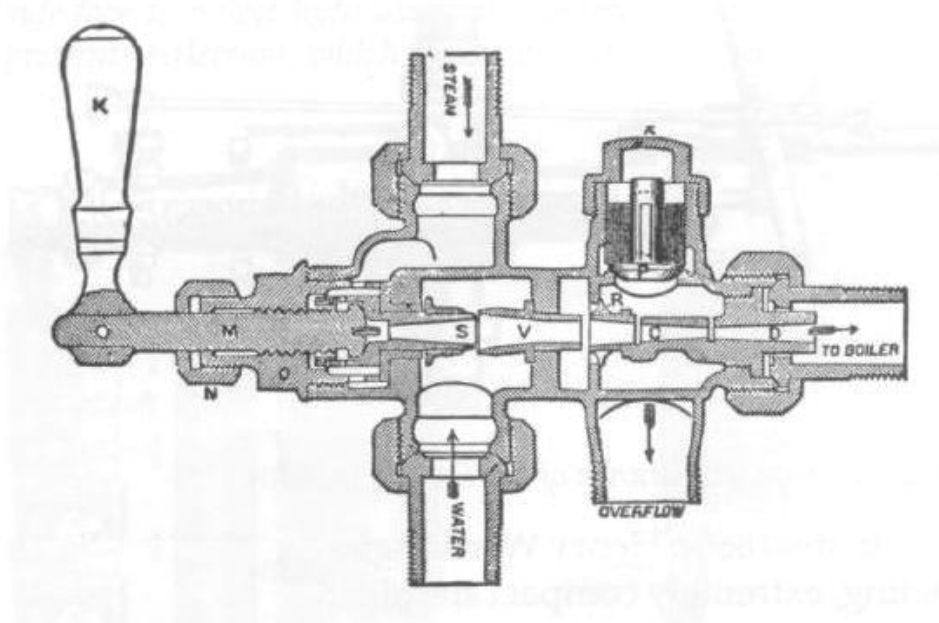

FIGURE B.8. Typical live steam injector (Bates 1996:15)

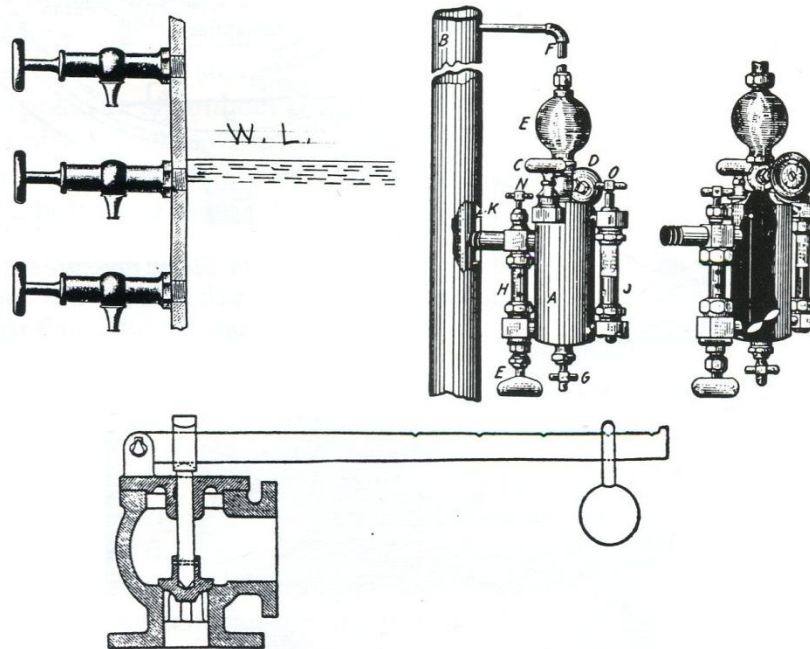

FIGURE B.9. Upper left: typical boiler gauge cocks. Upper right: typical hydrostatic lubricator with cutaway view. Bottom: Cross section of typical lever safety valve, showing movable weight, or “pea” (Adapted from Bates 1996:17,19,28)

REFERENCES

Amadon, George F.

1988 *Rise of the Ironclads*. Pictorial Histories Publishing Company, Missoula, MT.

Atherton, Charles

1851 *On Marine Engine Construction and Classification*. John Weale, Architectural Library, London, United Kingdom.

Bates, Alan

1968 *The Western Rivers Steamboat Cyclopoedum, or American Riverboat Structure & Detail, Salted with Lore, with a Nod to the Modelmaker*. Hustle Press, Leonia, NJ.

1996 *The Western Rivers Engineroom Cyclopoedum*. Cyclopoedum Press, Louisville, KY.

Bathe, Granville

1951 *Ship of Destiny: A record of the U.S. steam frigate Merrimac, 1855-1862*. Press of Allen, Lane, and Scott, Philadelphia, PA.

Baxter, James Phinney, III.

1933 *The Introduction of the Ironclad Warship*. Harvard University Press, Cambridge, MA.

Bell, Joseph Snowden

1912 *The Early Motive Power of the Baltimore and Ohio Railroad*. Angus Sinclair Co., Publishers, New York, NY.

<<http://books.google.com/books/reader?id=dlpAAAAIAAJ&printsec=frontcover&output=reader&pg=GBS.PP7>>.

Bishop, J. Leander

1864 *A History of American Manufacturers from 1608 to 1860*. Edward Young & Co., Philadelphia, PA.

<<http://books.google.com/ebooks/reader?id=K1YdAAAAIAAJ&printsec=frontcover&output=reader&pg=GBS.PA9>>. Accessed 25 Jan. 2012.

Bright, Leslie S., William H. Rowland, and James C. Bardon

1981 *CSS Neuse: A Question of Iron and Time*. Division of Archives and History, North Carolina Department of Cultural Resources, Raleigh.

Brooke, George M., Jr. (editor)

2002 *Ironclads and Big Guns of the Confederacy: The Journal and Letters of John M. Brooke*. Studies in Maritime History Series, University of South Carolina Press, Columbia.

Brown, David K.

1990 *Before the Ironclad: Development of Ship Design, Propulsion, and Armament in the Royal Navy, 1815-60*. US Naval Institute Press, Annapolis, MD.

1993 *Paddle Warships: The Earliest Steam Powered Fighting Ships, 1815-1850*. Conway Maritime Press, London, UK.

Bruce, Kathleen

1931 *Virginia Iron Manufacture in the Slave Era*. The Century Company, New York, NY.

Buchanan, Franklin

1862-1863 Buchanan and Screven Family Papers, 1801-1913. Southern Historical Collection, University of North Carolina, Chapel Hill.

Campbell, Peter B.

2009 The Development of Confederate Ship Construction: An Archaeological and Historical Investigation of Confederate Ironclads *Neuse* and *Jackson*. Master's Thesis, Program in Maritime Studies, East Carolina University, Greenville, NC.

Campbell, R. Thomas

2002 *Southern Service on Land and Sea: The Wartime Journal of Robert Watson CSA/CSN*. University of Tennessee Press, Knoxville.

2005 *Engineer in Gray: Memoirs of Chief Engineer James H. Tomb, CSN*. McFarland & Company, Jefferson, NC.

2006 The First Confederate Ironclad. *America's Civil War*: 46-52.

Canney, Donald L.

1990 *The Old Steam Navy: Frigates, Sloops, and Gunboats, 1815-1885*. US Naval Institute Press, Annapolis, MD.

Combs, Edwin L., III

1996 On Duty at Wilmington: The Confederate Navy on the Cape Fear River. Master's Thesis, Department of History, East Carolina University, Greenville, NC.

Confederate States of America

1863 *Report of Evidence Taken Before a Joint Special Committee of Both Houses of the Confederate Congress to Investigate the Affairs of the Navy Department*. G.P. Evans, Richmond, VA.

Continental Eagle Corporation

2009 Factory at War. PrattHistory.com, Continental Eagle Corporation, Prattville, AL. <http://www.pratthistory.com/factory_at_war.htm>. Accessed 20 Jan. 2012.

Coski, John M.

2005 *Capital Navy: The Men, Ships and Operations of the James River Squadron*. Savas Beatie LLC, New York, NY.

Daniel, Larry J., and Riley W. Gunter

1977 *Confederate Cannon Foundries*. Pioneer Press, Union City, TN.

Dent, John Horry

1840-1892 John Horry Dent Papers. W.S. Hoole Special Collections Library, University of Alabama, Tuscaloosa.

- Dew, Charles B.
1987 *Ironmaker to the Confederacy: Joseph R. Anderson and the Tredegar Iron Works*. Broadfoot, Wilmington, NC.
- Donnelly, Ralph W.
1959 The Charlotte, North Carolina, Navy Yard, CSN. *Civil War History* V: 72-79.
- Duffield, Ulysses Grant
1896 *The Neafie & Levy Ship and Engine Building Company (Penn Works)*. Franklin Printing Co., Philadelphia, PA.
- Durkin, Joseph T.
1954 *Confederate Navy Chief: Stephen R. Mallory*. University of Alabama Press, Tuscaloosa.
- Elliott, Robert G.
2005 *Ironclad of the Roanoke: Gilbert Elliott's Albemarle*. White Mane Publishing Co., Inc., Shippensburg, PA.
- Flanders, Alan B. and Neale O. Westfall (editors)
1998 *Memoirs of E. A. Jack: Steam Engineer, CSS Virginia*. Brandylane Publishers, White Stone, VA.
- Foster, Kevin J.
1986 Marine Steam Engines, 1807-1875: A Typology. *The Proceedings of the Seventeenth Annual Conference on Underwater Archaeology*. Fathom Eight, San Marino, CA.
- Freedley, Edwin T. (editor)
1856 *United States Mercantile Guide: Leading Pursuits and Leading Men, a Treatise on the Principal Trades and Manufactures of the United States*. Edward Young, Philadelphia, PA.
<<http://books.google.com/ebooks/reader?id=qvcYAAAAYAAJ&printsec=frontcover&output=reader&pg=GBS.PA4>>. Accessed 25 Jan. 2012.
- Gift, George Washington
1862-1876 George Washington Gift Letters. Southern Historical Collection, University of North Carolina, Chapel Hill.
- Gosnell, H. Allen
1949 *Guns on the Western Waters: The Story of River Gunboats in the Civil War*. Louisiana State University Press, Baton Rouge.
- Groundspeak, Inc.
2012 Leeds Iron Foundry—New Orleans, LA. U.S. National Register of Historic Places, Waymarking.com, Groundspeak, Inc.
<www.waymarking.com/cat/details.aspx?f=1&guid=060d7c79-e256-4ca5-a535-fd20de249eb9&st=2>. Accessed 21 Jan. 2012.

- Gulf Engineers and Consultants, Inc., and Tidewater Atlantic Research
 1992 Archeological Documentation and Testing of a Mid-Nineteenth Century Tugboat at Hutchinson Island, Savannah, Chatham County, Georgia: Final Report. Report to U.S. Army Corps of Engineers, Savannah District.
- Harris, Lynn
 2003 Wreck of the Golden Spike. *Legacy* 8 (1): 8-9.
- Hearn, Chester G.
 1993 *Mobile Bay and the Mobile Campaign*. McFarland & Company, Inc., Publishers, Jefferson, NC.
- Heyl, Erik
 1953 *Early American Steamers*, Vol. 4. Erik Heyl, Buffalo, NY.
- Hillery, Horace E. (editor)
 1961 West Point Foundry. *Putnam County Historian*. No publisher given. Patterson, NY.
- Holcombe, A. Robert, Jr.
 1978 The *Richmond* Class Confederate Ironclads. *CHAB News* 6: 16-18.
 1993 The Evolution of Confederate Ironclad Design. Master's Thesis, Program in Maritime Studies, East Carolina University, Greenville, NC.
- Jeter, Katherine Brash
 1987 Against All Odds: Lt. Jonathan H. Carter, CSN, and His Ironclad. *Louisiana History: The Journal of the Louisiana Historical Association* 28 (3): 263-288.
 1996 *A Man and his Boat: The Civil War Career and Correspondence of Lieutenant Jonathon H. Carter, CSN*. Center for Louisiana Studies, Lafayette.
- Johnson, Robert U. and Clarence C. Buel (editors)
 1887-1888 *Battles and Leaders of the Civil War*, 4 vols. The Century Co., New York, NY.
 Reprinted 1991 by The Archive Society, Harrisburg, PA.
- Kane, Adam Isaac
 2001 The Western River Steamboat: Structure and Machinery, 1811 to 1860. Master's thesis, Department of Anthropology, Texas A&M University, College Station.
- Kleber, John E. (editor)
 2001 *The Encyclopedia of Louisville*. The University Press of Kentucky, Lexington.
- Lambert, Andrew
 1984 *Battleships in Transition: The Creation of the Steam Battlefleet, 1815-1860*. US Naval Institute Press, Annapolis, MD.

- Lambert, Andrew (editor)
 1992 *Steam, Steel, and Shellfire: The Steam Warship 1815-1905*. Conway Maritime Press, Edison, NJ.
- Lander, Ernest M., Jr.
 1960 Charleston: Manufacturing Center of the Old South. *Journal of Southern History* 26 (3): 330-351.
- Lankford, Nelson D. (editor)
 1988 *An Irishman in Dixie: Thomas Conolly's Diary of the Fall of the Confederacy*. University of South Carolina Press, Columbia.
- Luraghi, Raimondo
 1996 *A History of the Confederate Navy*, Paolo E. Coletta, translator. US Naval Institute Press, Annapolis, MD.
- Lytle, William M. and Forrest R. Holdcamper
 1975 *Merchant Steam Vessels of the United States 1790-1868*. The Steamship Historical Society of America, Inc., Staten Island, NY.
- MacBride, Robert
 1962 *Civil War Ironclads: The Dawn of Naval Armor*. Chilton Books, Philadelphia, PA.
- Manuscript, Archives, and Rare Book Library
 1862-1865 Savannah Squadron Papers. Manuscript, Archives, and Rare Book Library, Robert W. Woodruff Library, Emory University, Atlanta, GA.
- Martin, William Francis
 1787-1884 William Francis Martin Papers. Southern Historical Collection, University of North Carolina, Chapel Hill.
- McClinton, Oliver Wood
 1948 The Career of the Confederate States Ram "Arkansas." *The Arkansas Historical Quarterly*, 7 (4): 329-333.
- McLaughlin, Augustus
 1864-1865 Augustus McLaughlin Letterbook, Confederate Naval Museum, Columbus, GA.
- Melton, Maurice
 1968 *The Confederate Ironclads*. Yoseloff, New York, NY.
- Merrill, James M.
 1962 Confederate Shipbuilding at New Orleans. *The Journal of Southern History* 28 (1): 87-93.
 1970 *Battle Flags South: The Story of Civil War Navies on Western Waters*. Fairleigh Dickinson University Press, Rutherford, NJ.

Mooney, James L. (editor)

1959-1981 *Dictionary of American Naval Fighting Ships*, 8 vols. Naval Historical Center, Department of the Navy, Washington, DC.

Morrison, John H. and Elwin M. Eldridge

1881-1921,1958 Elwin Eldridge Collection on John H. Morrison: 1881-1921,1958. MS006, The Mariners' Museum Library, Newport News, VA.

Mueller, Edward A.

1990 *Perilous Journeys: A History of Steamboating on the Chattahoochee, Apalachicola, and Flint Rivers, 1828-1928*. Historic Chattahoochee Commission, Eufaula, AL.

Mystic Seaport

2012 Harrison Loring Collection (Coll. 226). Mystic Seaport, Manuscript Collection Registers. <<http://library.mysticseaport.org/manuscripts/coll/coll226.cfm>>. Accessed 14 September 2012.

National Archives

Record Group 19, National Archives, Washington, DC and College Park, MD.

Record Group 45, National Archives, Washington, DC and College Park, MD.

Record Group 56, National Archives, Washington, DC and College Park, MD.

Record Group 109, National Archives, Washington, DC and College Park, MD.

Naval History and Heritage Command

2012 Confederate Forces Afloat. Ships Histories, Dictionary of American Naval Fighting Ships, Naval History and Heritage Command. <<http://www.history.navy.mil/danfs/cfa-list.htm>>. Accessed 21 Jan. 2012.

Neville, Bert

1961 *Directory of Steamboats with Illustrations and Lists of Landings on the Chattahoochee-Apalachicola-Flint-Chipola Rivers*. Coffee Printing Co., Selma, AL.

Panamerican Consultants, Inc., and Tidewater Atlantic Research

2007 In Situ Archaeological Evaluation of the CSS *Georgia*, Savannah Harbor, Georgia: Final Report. Report to U.S. Army Corps of Engineers, Savannah District.

Park, Carl D.

2007 *Ironclad Down: The USS Merrimack-CSS Virginia from Construction to Destruction*. US Naval Institute Press, Annapolis, MD.

Parker, Larry

2005 *For Want of a Nail: An Evaluation of the Confederate Ironclad's Construction History, Service History, Tactical & Strategic Employment*. MilitaryHistoryOnline.com. <<http://www.militaryhistoryonline.com/civilwar/articles/wantofnail.aspx>>. Accessed 24 Feb. 2011.

- Parker, William H.
1883 *Recollections of a Naval Officer, 1841-1865*. Scribners, New York, NY.
- Pearce, George F.
2000 *Pensacola During the Civil War: A Thorn in the Side of the Confederacy*. University Press of Florida, Gainesville.
- Peebles, Martin D.
1996 *CSS Raleigh: The History and Archaeology of a Civil War Ironclad in the Cape Fear River*. Master's Thesis, Program in Maritime Studies, East Carolina University, Greenville, NC.
- Peek, Charles Smith
1863-1865 Charles Smith Peek Papers, Collection of Dr. Charles Peery, Charleston, SC.
- Reanie, Neafie & Company
1844-1861 Reanie, Neafie & Company Papers, 1844-1861. MS102, The Mariners' Museum Library, Newport News, VA.
- Ripley, Warren
1984 *Artillery and Ammunition of the Civil War*, 4th edition. Battery Press, Charleston, SC.
- Rodgers, Bradley A.
1996 *Guardian of the Great Lakes: The U. S. Paddle Frigate Michigan*. University of Michigan Press, Ann Arbor.
- Roper, Stephen
1897 *Handbook of Land and Marine Engines Including the Modeling, Construction, Running, and Management of Land and Marine Engines and Boilers*, 9th edition. David McKay, Publisher, Philadelphia, PA.
- Scharf, J. Thomas
1886 *History of the Confederate States Navy from Its Organization to the Surrender of Its Last Vessel*. Rogers & Sherwood, New York, NY. Reprinted 1977 by Crown Publishers, Inc., New York, NY.
- Sheppard, Robert M., III
1990 U.S.S. *Cairo* Engines and Boilers. ASME Mississippi Section Landmark Ceremony Committee, American Society of Mechanical Engineers.
- Silverstone, Paul H.
1989 *Warships of the Civil War Navies*. US Naval Institute Press, Annapolis, MD.
2001 *Civil War Navies, 1855-1883*. The US Navy Warship Series, US Naval Institute Press, Annapolis, MD.

- Sloan, Edward W., III
 1965 *Benjamin Franklin Isherwood, Naval Engineer*. US Naval Institute Press, Annapolis, MD.
- Smith, Edgar C.
 1937 *A Short History of Naval and Marine Engineering*. Cambridge University Press, Cambridge, United Kingdom.
- Smith, Myron J., Jr.
 2011 *The CSS Arkansas: A Civil War Ironclad on Western Waters*. McFarland & Company, Inc., Publishers, Jefferson, NC.
- SS Canadiana and Mr. Lee Online
 2012 Appendix B: The Buffalo Dry Dock. The S.S. Canadiana History Book, SS Canadiana and Mr. Lee Online. <sscanadiana.com/buffdrydock.html>. Accessed 21 Jan. 2012.
- Standard, Diffie W.
 1954 *Columbus, Georgia, in the Confederacy*. The William-Frederick Press, New York, NY.
- Still, William N., Jr.
 1965 Facilities for the Construction of War Vessels in the Confederacy. *The Journal of Southern History* 31 (3): 285-304.
 1985 *Iron Afloat: The Story of the Confederate Armorclads*. University of South Carolina Press, Columbia.
 1987 *Confederate Shipbuilding*. University of Georgia Press, Athens.
 1989 *The Savannah Squadron*. Coastal Heritage Press, Savannah, GA.
- Still, William N., Jr. (editor)
 1997 *The Confederate Navy: The Ships, Men and Organization, 1861-65*. US Naval Institute Press, Annapolis, MD.
- Taggart, Lewis Williams
 1991 Technology and the Confederate Navy. Master's thesis, University of Tulsa, Tulsa, OK.
- Thiesen, William H.
 2006 *Industrializing American Shipbuilding: The Transformation of Ship Design and Construction, 1820-1920*. University Press of Florida, New Perspectives on Maritime History and Nautical Archaeology, No. 8.
- Tomblin, Barbara B.
 1988 From Sail to Steam: The Development of Steam Technology in the U.S. Navy 1838-1865. Doctoral dissertation, Graduate Program in History, Rutgers University, New Brunswick, NJ.

Turner, Maxine

1988 *Navy Gray: A Story of the Confederate Navy on the Chattahoochee and Apalachicola Rivers*. University of Alabama Press, Tuscaloosa.

U.S. Navy Department

1894-1922 *Official Records of the Union and Confederate Navies in the War of the Rebellion*, 2 series, 30 vols. Government Printing Office, Washington, DC. Reprinted 1987 by The National Historical Society, Harrisburg, PA.

1963 *Dictionary of American Naval Fighting Ships*, Vol. II. Government Printing Office, Washington, DC.

U.S. Supreme Court

1883 *Atlantic Works v. Brady*, 107 U.S. 192. U.S. Supreme Court Center, Justia.com. <<http://supreme.justia.com/us/107/192/case.html>>. Accessed 21 Jan. 2012.

U.S. War Department

1880-1901 *The War of the Rebellion: A Compilation of the Official Records of the Union and Confederate Armies*, 2 series, 79 vols. US War Department, Washington, DC. Reprinted 1985 by The National Historical Society, Harrisburg, PA.

Watts, Gordon P.

1999 Underwater Archaeological Documentation of the Remains of the Ironclad CSS *North Carolina*, Brunswick County, North Carolina. Report to Environmental Resources Branch, U.S. Army Engineer District, Wilmington, NC.

Watts, Gordon P., Jr., Richard Stephenson, William N. Still, Jr., Wesley K. Hall, Bradley A. Rodgers, Kathryn Bequette, David Beard, and Kevin Foster

1990 *An Investigation of the Remains of the Confederate Gunboat CSS Chattahoochee*. Report to James W. Woodruff, Jr. Confederate Naval Museum, Columbus, GA, from the Program in Maritime History and Underwater Research, East Carolina University, Greenville, NC.

Way, Frederick, Jr.

1983 *Way's Packet Directory, 1848-1994*. Ohio University Press, Athens.

Warner, James H.

1862-1865 James Warner Letterbook, Port Columbus National Civil War Naval Museum, Columbus, GA.

Wells, Tom Henderson

1971 *The Confederate Navy: A Study in Organization*. University of Alabama Press, Tuscaloosa.

Wexler, Charles James

2008 "The Ordinary Gunboats": The CSS *Chicora*, the CSS *Palmetto State*, and the Battle off Charleston Harbor, January 31, 1863. Master's Thesis, College of Charleston and the Citadel, Charleston, SC.

Wilson, Clyde E.

1938 Gunboat *Baltic* Papers. Public Information Subject Files—Navy, SG11146—Folder 10, Alabama Department of Archives and History, Montgomery.

Wright, Henry X.

1859-1874 The Henry X. Wright Papers, 1859-1874. MS0072, The Mariners' Museum Library, Newport News, VA.