

VERNACULAR IN CURVES:
THE MYTHOLOGIZING OF THE GREAT LAKES WHALEBACK

by

Joseph Thaddeus Lengieza

April, 2016

Director of Thesis: Dr. Bradley Rodgers

Major Department: Maritime Studies, History

The “whaleback” type of bulk commodity freighter, indigenous to the Great Lakes of North America at the end of the nineteenth century, has engendered much notice for its novel appearance; however, this appearance masks the essential vernacularity of the vessel.

Comparative disposition analysis reveals that whalebacks experienced longevity comparable to contemporary Great Lakes freighter of similar construction material and size, implying that popular narrative overstates whaleback abnormality. Market and social forces which contributed to the rise and fall of the whaleback type are explored.

VERNACULAR IN CURVES:
THE MYTHOLOGIZING OF THE GREAT LAKES WHALEBACK

A Thesis

Presented To the Faculty of the Department of Maritime Studies

East Carolina University

In Partial Fulfillment of the Requirements for the Degree

Master of Arts in Maritime Studies

by

Joseph Thaddeus Lengieza

April, 2016

© Joseph Thaddeus Lengieza, 2016

VERNACULAR IN CURVES:
THE MYTHOLOGIZING OF THE GREAT LAKES WHALEBACK

By

Joseph Thaddeus Lengieza

APPROVED BY:

DIRECTOR OF THESIS: _____
Bradley Rodgers, Ph.D.

COMMITTEE MEMBER: _____
Nathan Richards, Ph.D.

COMMITTEE MEMBER: _____
David Stewart, Ph.D.

COMMITTEE MEMBER: _____
Benjamin Ford, Ph.D.

CHAIR OF THE DEPARTMENT OF HISTORY:

Christopher Oakley, Ph.D.

DEAN OF THE GRADUATE SCHOOL:

Paul J. Gemperline, PhD

DEDICATION

ILLI ROBUR ET AES TRIPLEX
CIRCA PECTVS ERAT, QVI FRAGILEM TRVCI
COMMISIT PELAGO RATEM
PRIMVS.

ACKNOWLEDGEMENTS

I owe a great debt of gratitude to the patience of my wife, family, committee, and especially my advisor, who has been like unto the Righteous Job himself. Punctuated by illness, career turmoil, and the other circumstances of life, this work has been a long, slow clawing to windward, and I am grateful for the companionship of all who have been fellow travelers along the way. Belated thanks as well to Umberto Eco, whose *How to Write a Thesis* was eminently helpful.

TABLE OF CONTENTS

LIST OF TABLES	viii
LIST OF FIGURES	ix
CHAPTER 1: GREAT LAKES WHALES AND WHERE TO FIND THEM	1
Introduction	1
General Description of Vessel Type	4
CHAPTER 2: TRADE AND CIVILIZATION MOVE WEST.....	16
Infrastructure	24
Patents.....	30
Growth and Consolidation.....	31
The Cyclical Picture.....	33
Summary.....	34
CHAPTER 3: ALEXANDER MCDOUGALL.....	37
Early Life.....	38
The Formative Years.....	39
The Vessels	43
CHAPTER 4: THE FLEET	56
Boom Times	57
A Fleet of Orphans	60
CHAPTER 5: RECKONING.....	64
Conclusion.....	81
WORKS CITED	85
Primary Sources.....	85
Secondary Sources.....	87

APPENDIX A: SHIP DISPOSITION DATA SET AND COMMENTARY	92
Data Set Parameters and Methodology.....	92
Selected Statistics Derived from the Data Set.....	96
Data Set in Tabular Form.....	98

LIST OF TABLES

1.1	Selected Particulars of Whaleback Propellers.....	9
1.2	Selected Particulars of Whaleback Barges.....	10
2.1	Total Annual Shipments of Lake Superior Iron Ore by Ranges	20
2.2	Population Growth in Selected U.S. Cities	24

LIST OF FIGURES

1.1	“Whaleback Freighter Locking Through Canal, Sault Ste. Marie, Mich.”	4
1.2	Plans of the Whaleback Steamer <i>Colgate Hoyt</i>	6
1.3	<i>Alexander McDougall</i>	7
1.4	The Whaleback Passenger Steamer <i>Christopher Columbus</i>	8
1.5	<i>R. J. Hackett</i>	13
1.6	“Elevators and Shipping, Buffalo, NY”.....	14
2.1	General Map of the Great Lakes	17
2.2	“The Poe Locks at Sault Ste. Marie Nearing Completion”.....	28
3.1	Portrait of Alexander McDougall	38
3.2	McDougall’s Initial “Tow Boat” Patent	45
3.3	McDougall’s 1888 Patent	46
3.4	Samuel Calthrop’s Streamlined Train	47
3.5	Winans’ Steamship.....	49
3.6	The Cleopatra’s Needle Barge	51
3.7	HMS <i>Polyphemus</i>	52
4.1	Doxford Turret Ship.....	62
4.2	Dracone Barge.....	63
5.1	Cause of Loss of All Bulk Freighters.....	66
5.2	Cause of Loss of Wooden Freighters.....	67
5.3	Cause of Loss of Wooden Freighters, Excluding Burning.....	68
5.4	Cause of Loss of Whaleback Propellers.....	69
5.5	Cause of Loss of Freighters of Comparable Tonnage to Whalebacks.....	70
5.6	Cause of Loss of Ferrous Non-Whaleback Freighters.....	71

5.7 Cause of Loss of Freighters 4,000 Tons or Greater.....	72
5.8 Cause of Loss of Whaleback Barges.....	73
5.9 Average Freighter Longevity in Years.....	75
5.10 The Telescoping Hatch Cover.....	78
5.11 Hulett Unloader.....	79
5.12 Ships Wait to Transit the Locks at Sault Ste. Marie.....	80

CHAPTER 1: GREAT LAKES WHALES AND WHERE TO FIND THEM

“A thing is a thing, not what is said of that thing.”

Attributed to Susan Sontag

Introduction

Out of all the vessels in history, few have been more unjustly burdened with moral and intellectual baggage than the whaleback. Whalebacks of the Great Lakes bulk commodities trade in the late nineteenth and early twentieth centuries were not as remarkable as has come to be believed. They were not especially safe, nor were they fearfully dangerous. They were not golden geese, nor white elephants. As feats of engineering, they were neither tremendous prodigies nor vast follies, and yet all of these have been asserted, believed and repeated. Whalebacks were unusual in appearance, certainly, but on the balance they were not atypical craft for their time and place.

Certainly the whaleback has no greater symbolic meaning, although attempts have been made to invest them with it (Bowen 1946:181-182; Wilterding 1969:2; Frew 2008:169). The narrative they are best equipped to carry is perhaps that in tumultuous times fortunes could rise and fall quickly. The weight of general opinion, insofar as opinion about them was ever general, has swayed between two poles: the first that, as Bowen opines, they were “truly a symbol of Great Lakes ingenuity” (Bowen 1946:182); the second that they were self evident dead ends in the development of shipbuilding. Thus when the (British) Institution of Naval Architects considered the whaleback design, the society’s vice president, Mr. B. Martell declared a whaleback “a vessel, no one can doubt for a moment, entirely unfit for ocean-carrying purposes...” only to be interrupted by a second member, Mr. John Corry, interjecting “any

purpose” (Goodall 1892:199). This bi-polar image is very much off the mark, but it has made for good stories. The real story, though, is interesting too.

The conventional narrative of whalebacks is that they were economic failures (Daley 2000:8-12); however, it is possible to argue that based on the performance of the vessels themselves, and based on the survival of elements of their design, that the ships acquitted themselves reasonably well. This standard narrative of whalebacks, found mainly in non-academic popular history, is actually a flattening and conflation of three separate narratives: that of the technical aspects of the vessels themselves; that of the company which built them, the American Steel Barge Company; and that of their inventor, Captain Alexander McDougall. These stories tend to resolve into two types. Earlier Gilded-Age accounts emphasize elements of innovation and progress, reinforcing America’s contemporary self-image. In this vein are the *Los Angeles Times* article, which trumpets the whaleback *Christopher Columbus* as “probably the most noteworthy vessel, as to model, ever built” (*Los Angeles Times* 1892:6), and the *Washington Post* account, which states, “In the opinion of many experts the success of the [whaleback] *Wetmore* foreshadows a revolution in shipbuilding” (*The Washington Post* 1891:4). Later accounts tend to focus on the perceived “serious defects” of the design, as Wright describes it (Wright 1969:52). In either case, a form of ruling theory may be at work. Sometimes the aim, stated or otherwise, is not a strict adherence to the best available facts, but rather to “retell” “wondrous tales” (Bowen 1946).

The following pages will attempt to disentangle these three separate narratives, while examining the processes through which they were shaped. Insofar as possible, McDougall’s whalebacks will be considered independently of the fortunes of their inventor and the company which he founded to build them. These vessels will be placed into a larger context in the

evolution of shipbuilding and the development of steel as a shipbuilding material. Newly introduced statistical comparison of whalebacks with contemporary vessels will argue against the idea that the whaleback design can be considered a failure. The centerpiece of the argument presented is disposition research comparing the relative longevity of whalebacks and comparable contemporaneous Great Lakes vessels, finding whalebacks to not be statistically shorter lived than their competitors. The interplay of competing narratives has masked the essentially vernacular nature of these vessels.

What is a whaleback? In the very simplest terms it is a sort of rounded-off bulk freighter, conceived and built by its inventor, Alexander McDougall, on North America's Great Lakes, at the end of the nineteenth century (McDougall 1932:32-33). As can readily be seen in Figure 1.1, which illustrates *A. D. Thompson*, a typical whaleback, the vessels are cigar-shaped, built to rest low in the water when loaded, and bear a passing resemblance to a submarine operating in surface mode. A more thorough technical description will follow in this chapter. As McDougall's whalebacks were only built for a period of nine years, there has been an inordinate amount of focus on why they failed; however, discussions of failure need to be informed by the nuance of time and place (Daley 2000:9). By placing whalebacks in the context of relevant vessel types, it will be possible to make a more balanced appraisal of their success or failure. It will also be shown, in Chapter 2, that the unique economic situation of America in the late nineteenth century, particularly on the upper Great Lakes, was a critical factor in both the rise and demise of the whaleback type. Exploring the lineage of these vessels, both predecessors and antecedents, and considering how whalebacks interacted with competing models, opens up larger themes in the industrial, economic, and intellectual history of turn of the century America, and is ultimately a story of how cultural and market forces sometimes eddy and flow around powerful

individuals. It is also an opportunity to examine how the conventions of storytelling impose themselves onto history. Every story needs a protagonist, a series of causally related incidents, and some sort of resolution or moral, and there is a tendency to supply these elements even when they do not strictly fit the facts (Bal 1997:3-15).

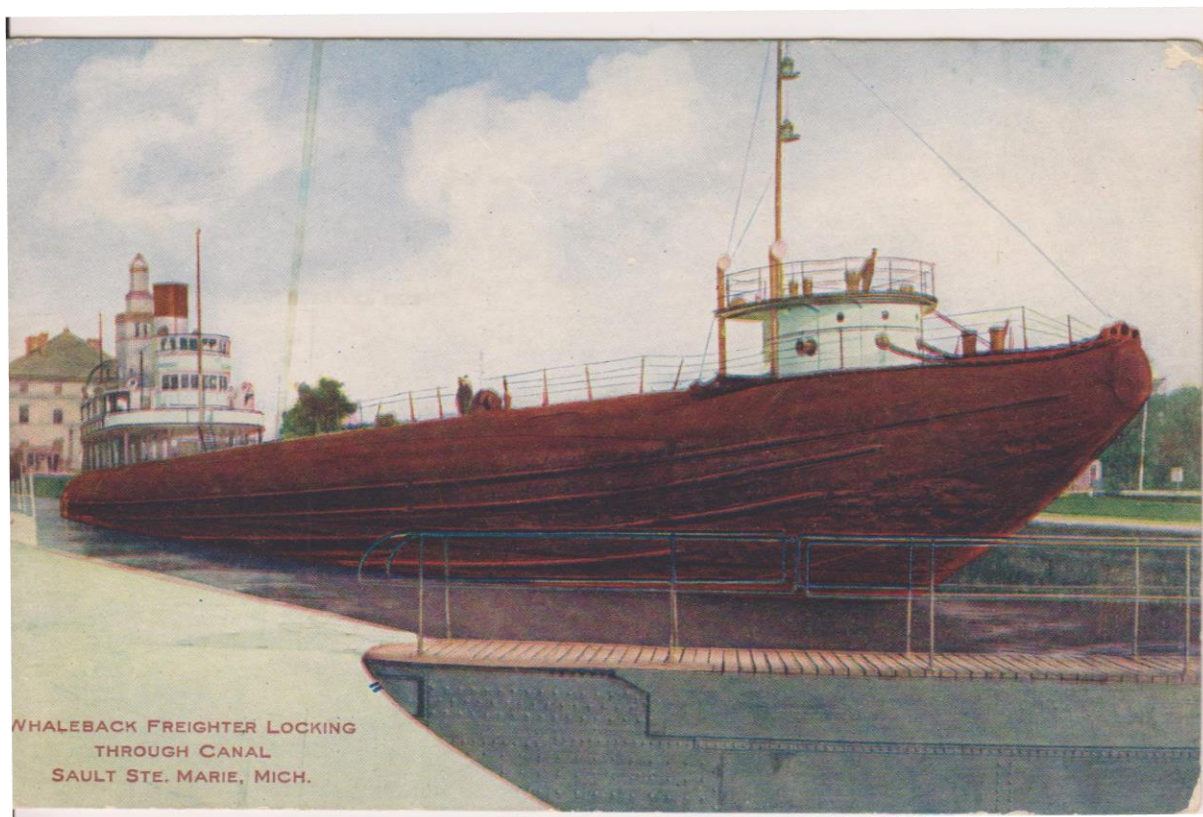

FIGURE 1.1. “Whaleback Freighter Locking through Canal, Sault Ste. Marie, Mich.” Identified on reverse as Steamer *A.D. Thompson*, this whaleback shows the standard hull-form and layout of a whaleback propeller. (Postcard, V. O. Hammon Publishing Company, circa 1900.)

General Description of Vessel Type

Native to the Great Lakes, and built there almost exclusively, the whaleback design nonetheless had an influence on ship design on a world scale. It was a bold experiment in the possibilities of a new shipbuilding medium, namely steel. The whaleback type is rarely given much credit for influencing future designs; nonetheless it can be seen as having a clear place in two shipbuilding traditions. It is a slight outlier in the general development of Great Lakes bulk freighters

(Devendorf 1995:24), and is difficult to understand if not kept in the strict context of its own time and place. It also fits broadly into the larger tradition of experimentation in hull design, a process greatly abetted by the development of iron and steel as shipbuilding media (Guthrie 1970:v-vi).

The general whaleback type included several classes of self-powered ships and unpowered barges of various sizes, as well as one passenger ship. All were designed by Alexander McDougall, and all were constructed between 1888 and 1897 (Wilterding 1969:15-68; Table 1.1; Table 1.2). All but one were built by McDougall's American Steel Barge Company (Wilterding 1969:67). Various other vessels and vessel classes share some degree of kinship with the whaleback and shall be discussed in Chapters 3 and 4.

A scholar of the subject, C. Roger Pellet, provides a list of six defining whaleback characteristics and ancillary features, which is concise and definitive enough to deserve reproducing at length:

- A spoon-shaped bow. The first whaleback ship (Barge 101) had a conical-shaped bow intended to reduce the tendency of a barge to yaw when towed. The conical shape was refined to a spoon shape on later barges and McDougall chose to retain it when he began to build powered vessels.
- Low freeboard. To minimize weight, McDougall eliminated the forecastle deck usually found on ships, and designed his whaleback with a straight sheer. (The deck line did not rise as it approached the ship's bow and stern.)
- Arch-shaped decks. The arch shape allowed the deck to shed water and permitted a lighter structure, further reducing hull weight and construction cost.
- Narrow stern. Unlike conventional Great Lakes ships built with wide, fan-shaped sterns, whalebacks were built with narrow sterns that reduced the tendency of the stern to lift to a passing wave.
- High-integrity hatches. Since there was no forecastle or forward deck sheer to protect them, conventional hatches with wooden covers would not have provided sufficient watertight integrity. Instead, all whalebacks were built with steel-plate hatches secured with bolts and sealed with gaskets.
- Turrets. To provide entry below deck, openings for whalebacks were

placed in turrets erected on top of the hull The bow turret also provided a protected space to house the anchor windlass, and the stern turrets provided an elevated foundation for the pilot house, the galley, and crew quarters.

- Other features: Whalebacks also included several features aside from the hull that were invented and patented by McDougall. Included were special anchors, watertight skylights, and towing and anchor handling fairleads (Pellet 2008:4).

The major features are visible in Figure 1.2, lines drawings of *Colgate Hoyt* from Bowling Green University's Historical Collection of the Great Lakes. These are the basic parameters, but it will serve no purpose to observe too high a degree of orthodoxy. Thus, a whaleback retrofitted with low-integrity hatches is still a whaleback for our purposes, albeit a less capable one. An altered design, such as a whaleback with a conventional bow, or a flat cargo deck, will still, even with its watered-down pedigree, have some place in this discussion. For example, the last whaleback built, *Alexander McDougall* sported a conventional bow and a forward bridge, but exhibits the other diagnostic features of the type, as can be seen in Figure 1.3.

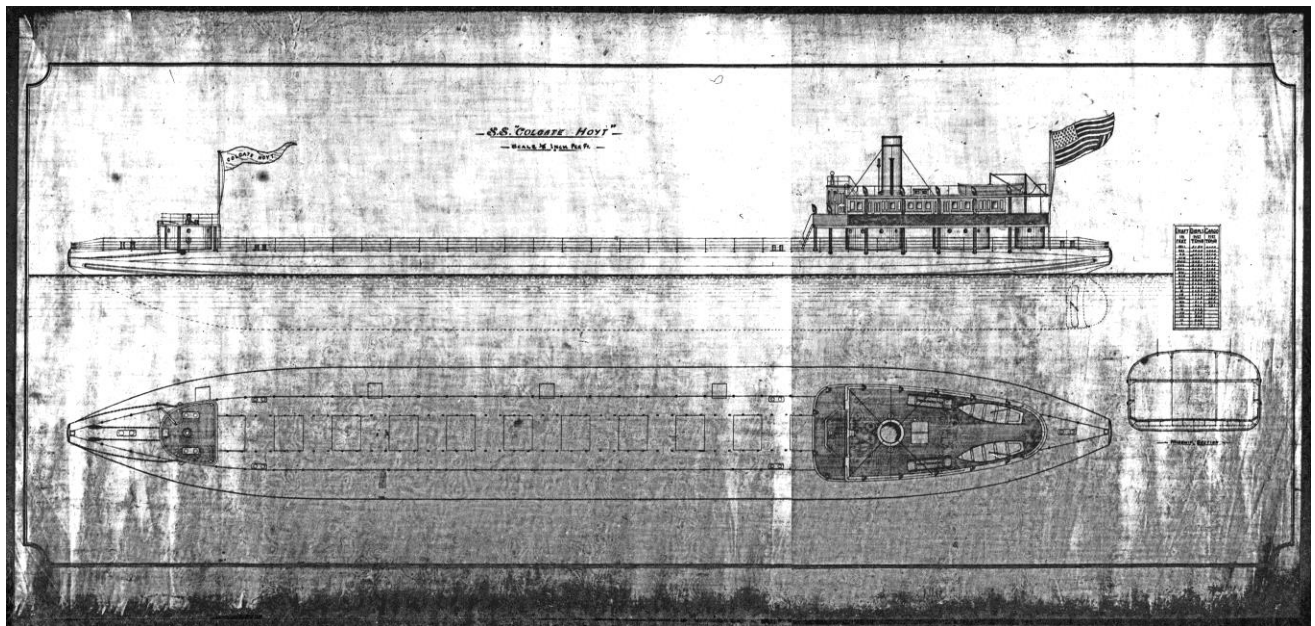

FIGURE 1.2. Plans of the whaleback steamer *Colgate Hoyt* (Amship Predecessors 1888-1898:Frame 7, circa 1890).

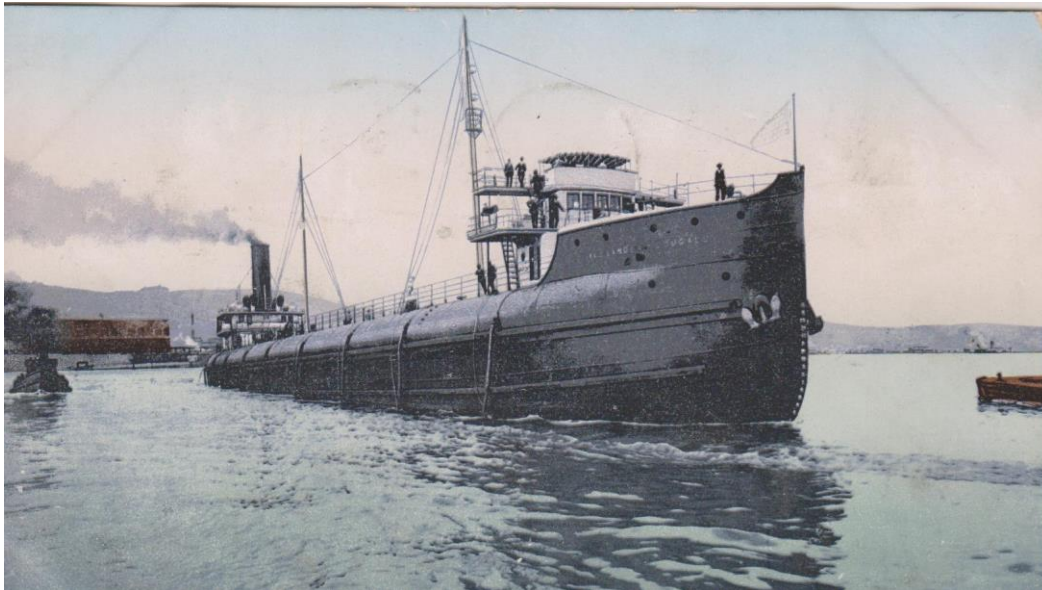

FIGURE 1.3. *Alexander McDougall*, the last whaleback built, was the only whaleback constructed with a conventional bow (Postcard, W.C Milner and Company, postmarked 1907).

Tables 1.1 and 1.2 list every whaleback built, with select particulars. Table 1.1 lists propellers, that is, self-propelled steam vessels. Table 1.2 lists unpowered barges. Three of the ships included on Table 1.1 are especially unusual. The propeller *Sagamore*, not to be confused with the eponymous barge, was an unauthorized copy of McDougall's design and never saw service in the Great Lakes (Wilterding 1969:67). *City of Everett* was assembled from prefabricated pieces on the Pacific Coast; it too never saw service on the lakes (Wilterding 1969:63). *Christopher Columbus* was purpose built as a passenger vessel and had a long and successful career, most notably at the Chicago World's Fair (McDougall 1932:35-37; Wilterding 1969:43.45). Illustrated in Figure 1.4, *Christopher Columbus* will have little place in the following discussion. All of the barges were built for use as consorts, that is, they were meant to be towed by powered vessels of a similar size, a common arrangement at the time on the Great Lakes (Thompson 1991:49). Many of these barges ended their careers on the Atlantic (Table

1.2). Although the locations of several whaleback wrecks are known (Frew 2008:161-164), the only surviving example above water is in Superior, Wisconsin, the museum ship *Meteor*, built as *Frank Rockefeller* (Zoss 2007:127).



FIGURE 1.4. The whaleback passenger steamer *Christopher Columbus* (Postcard, A. C. Bosselman and Company, Postmarked 1907).

NAME	TON (BUILT)	LENGTH	LAUNCHED	END	COMMENTS
<i>Colgate Hoyt</i>	1253	276	1890	1909	Off Lakes 1906. Wrecked 1909, NJ.
<i>Joseph L. Colby</i>	1245	265	1890	1935	Periodically off Lakes. Scrapped 1935.
<i>E. B. Bartlett</i>	1400	265	1891	1916	Off Lakes 1905, sank 1916, Cape Cod Canal.
<i>A. D. Thompson</i>	1400	265	1891	1936	Off Lakes 1905-1922. Scrapped 1936.
<i>Pathfinder</i>	2425	340	1892	1933	Sold for scrap 1933.
<i>James B. Colgate</i>	1713	308	1892	1916	Sank, Lake Erie.
<i>Samuel Mather</i>	1713	308	1892	1924	Sank, Lake Huron.
<i>John B. Trevor</i>	1713	362	1895	1935	Off Lakes 1918. Scrapped 1935.
<i>John Ericson</i>	3201	390	1896	1966	Out of service 1966, scrapped 1967.
<i>Frank Rockefeller</i>	2760	366	1896	1972	Out of service 1972; museum.
<i>Alexander McDougall</i>	3686	413	1898	1947	Scrapped 1947.
<i>Charles W. Wetmore</i>	1399	265	1891	1892	Off Lakes 1891, wrecked 1892, Coos Bay, OR.
<i>Thomas Wilson</i>	1713	308	1892	1902	Collision, sank.
<i>Washburn</i>	2234	320	1892	1936	Scrapped, 1936.
<i>Pillsbury</i>	2234	320	1892	1934	Wrecked.
<i>Sagamore</i>	2140	297	1893	1917	Built in UK; Torpedoed; never entered Great Lakes
<i>City of Everett</i>	2504	346	1894	1923	Built Everett, WA; sank 1923. Never entered Great Lakes.
<i>Christopher Columbus</i>	1511	362	1893	1936	Passenger vessel. Scrapped 1936.

TABLE 1.1. Selected particulars of whaleback propellers, from the dataset in appendix A, compiled with special attention to Devendorf 1995 and Daley 2000.

NAME	TONNAGE	LENGTH	LAUNCHED	END	COMMENTS
<i>Barge 101</i>	428	178	1888	1908	Sank, Maine coast.
<i>Barge 102</i>	1192	253	1889	1905	Foundered Cape Charles, VA.
<i>Barge 103</i>	1192	253	1889	1909	Foundered, Sandy Hook, NJ.
<i>Barge 104</i>	1295	276	1890	1908	Foundered, vicinity Cleveland, OH.
<i>Barge 105</i>	1295	276	1890	1910	Foundered, vicinity Fire Island Lightship, NY.
<i>Barge 107</i>	1295	276	1890	1913	Sank Nantucket Shoals, 1913.
<i>Barge 109</i>	1227	265	1891	1914	Foundered Montauk Point, NY.
<i>Barge 110</i>	1296	265	1891	1932	Explosion, burned at dock, sank, St Rose, LA.
<i>Barge 111</i>	1227	265	1891	1916	Collision, sank, Hampton Roads, VA.
<i>Barge 115</i>	1169	256	1891	1899	Stranded, Pic Island, Lake Superior
<i>Barge 116</i>	1169	256	1891	1946	Scrapped, TX, 1946.
<i>Barge 117</i>	1310	285	1891	1926	Sold British 1926, no further record.
<i>Barge 118</i>	1310	285	1891	1946	Scrapped, TX, 1946.
<i>Barge 122 (Sagamore)</i>	1601	308	1892	1901	Collision, sank, Whitefish Bay.
<i>Barge 126</i>	1128	264	1892	1905	Stranded, Buzzard's Bay, MA.
<i>Barge 127</i>	1128	264	1892	1936	Scrapped 1936, New Orleans, LA
<i>Barge 129</i>	1310	292	1893	1902	Collision, sank, 1902.
<i>Barge 130</i>	1310	292	1893	1924	Scrapped, TX, 1924.
<i>Barge 131</i>	1310	292	1893	1946	Scrapped, TX, 1946.
<i>Barge 132</i>	1310	292	1893	1927	Foundered, Freeport, TX
<i>Barge 133</i>	1310	292	1893	1911	Foundered, Fire Island, NY.
<i>Barge 134</i>	1310	292	1893	1912	Stranded, Hampton Roads, VA.
<i>Barge 137</i>	2480	345	1896	1965	Scrapped, 1965
<i>Barge 139 (Alexander Holley)</i>	2721	377	1896	1965	Scrapped, 1965
<i>Barge 201</i>	664	182	1890	1919	Stranded, Sandy Hook, NJ.
<i>Barge 202</i>	665	182	1890	1908	Foundered, Barnegat, NJ.

TABLE 1.2. Selected particulars of whaleback barges, from the dataset in appendix A, compiled with special attention to Devendorf 1995 and Daley 2000.

It is the nature of ships, as tremendously large investments of capital, in any era, to change as they age, and to be, if they live long enough, reinvented several times over. Thus, a large ship, built to specific purpose and embodying the latest innovations, will decades later find

itself outmoded and relegated to a less demanding and usually less lucrative trade. Later yet, it may be cut down to a barge, or a hulk, not worth repowering, but still of some use. Finally, the vessel might end its days as a wharf extension or scrap yard (Rodgers and Green 2003:30,42; Rodgers et al. 2006:1-2,18). So it is, that in ships at least, obsolescence is a natural part of life. A long career that ends in a whimper, rather than with a bang, should not necessarily be taken as a failure.

To contextualize whalebacks, one must begin with their trade: they were by and large bulk freighters (Table 1.1; Table 1.2). Dry bulk cargo is any sort of high-mass, low value granular commodity, the sort of thing which is bought by the ton and delivered in a pile. Taconite (unrefined iron ore pellets), grain, coal, and gravel are all prime examples, and all are well-represented in the Great Lakes bulk trade (Livingstone 1891:5). A bulk freighter is essentially a large empty space for cargo with a ship built around it. As form follows function, the whaleback naturally shares a great deal in common with the conventional Great Lakes freighter. Both were built as large as available capital and technology would allow, within the limits imposed on them by the waterways on which they were obligated to travel, as detailed in Chapter 2. Both had long parallel midsections, with most of their deck space devoted to hatches, maximizing access to the un-partitioned hold which comprised most of their interior. In both, the superstructure was confined principally to the extreme ends of the vessel. Both mounted machinery aft, minimizing the run between engine and propeller and maximizing space for cargo forward. In form, the conventional lake freighter is particularly boxy, nearly square in section for most of her length, usually terminating in a plumb, wedge-shaped bow and a conventional rounded transom. Whalebacks in section are slightly rounded squares, terminating in blunted

conical bows and sterns (*Amships Predecessors* 1888-1898; Thompson 1991:30-41; Devendorf 1995:7-49; Riesenbergs 1936:304).

The lineage of all lake freighters is generally traced back to a single sire, the wooden-hulled steamer *R. J. Hackett* of 1869 (Figure 1.5). The first ship purpose-built for the Great Lakes bulk trade, *Hackett* was 211 feet in length and 33 feet abeam, essentially at the structural limits of wooden hull construction technology (Devendorf 1995:7,53; Thompson 1991:22-23). Her features became the archetype for Great Lakes freighter design up to the present day: boxy lines, a forward bridge superstructure, engine or engines aft, with additional accommodation superstructure above, and a long run of deck hatches between to maximize speed of loading and unloading (Devendorf 1995:7-8; Thompson 2000:18; Reisenberg 1936:304). The forward bridge was handy in navigating tight inland waterways and cargo docks. The proliferation of hatches reflected the short routes on the Lakes. Lakers spent a much greater portion of their lives at loading and unloading docks, compared to ocean steamers, and so the ability to load and unload quickly was an economic necessity (Lafferty 1998:155-156).

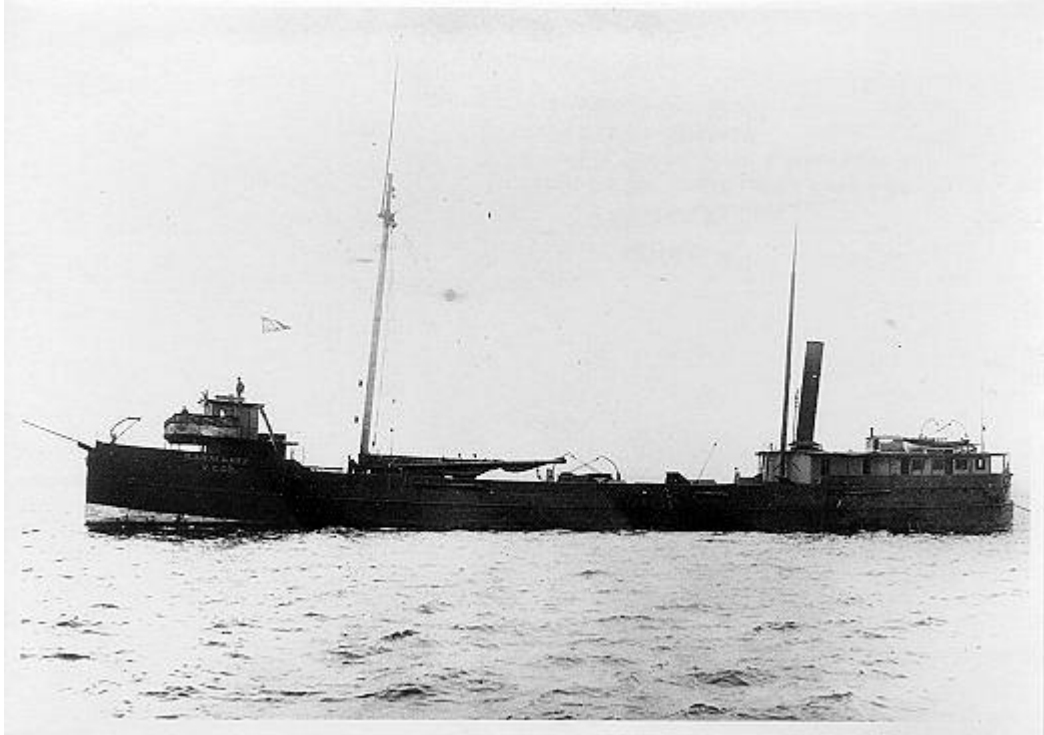

FIGURE 1.5. *R.J. Hackett*, generally acknowledged as the first example of a conventional lake freighter (Historical Collections of The Great Lakes, Bowling Green University. Accessed online: <http://greatlakes.bgsu.edu/vessel/view/000015>).

At the beginning of the nineteenth century, sail was the primary driver of waterborne trade. The launch of *Hackett* in 1869 (Devendorf 1995:8) was a signal of the eventual eclipse of sail by steam, although sail in the bulk trade persisted through the turn of the century, typically as auxiliary power for barges designed to be towed by a steamer. At the time *Hackett* was built, available engines were capable of moving more tonnage than available hull technology could carry, leading to a system of steamers towing dedicated consort barges, a model which did not fade out until the early twentieth century (Thompson 1991:48-49).

Figure 1.6 represents a cross-section of Great Lakes trade at the turn of the century. From left to right, foreground, are a whaleback steamer, a conventional steamer, and probably a sailing schooner barge. The whaleback is apparently empty, or nearly so, as it is showing the characteristic high bow for which whalebacks were noted when running light. The conventional

steamer has the typical forward bridge/machinery aft layout. The third vessel is presumptively an unpowered barge, based on the relative lack of superstructure aside from the three fore-and-aft rigged masts (Devendorf 1995:7-10, 18-29).

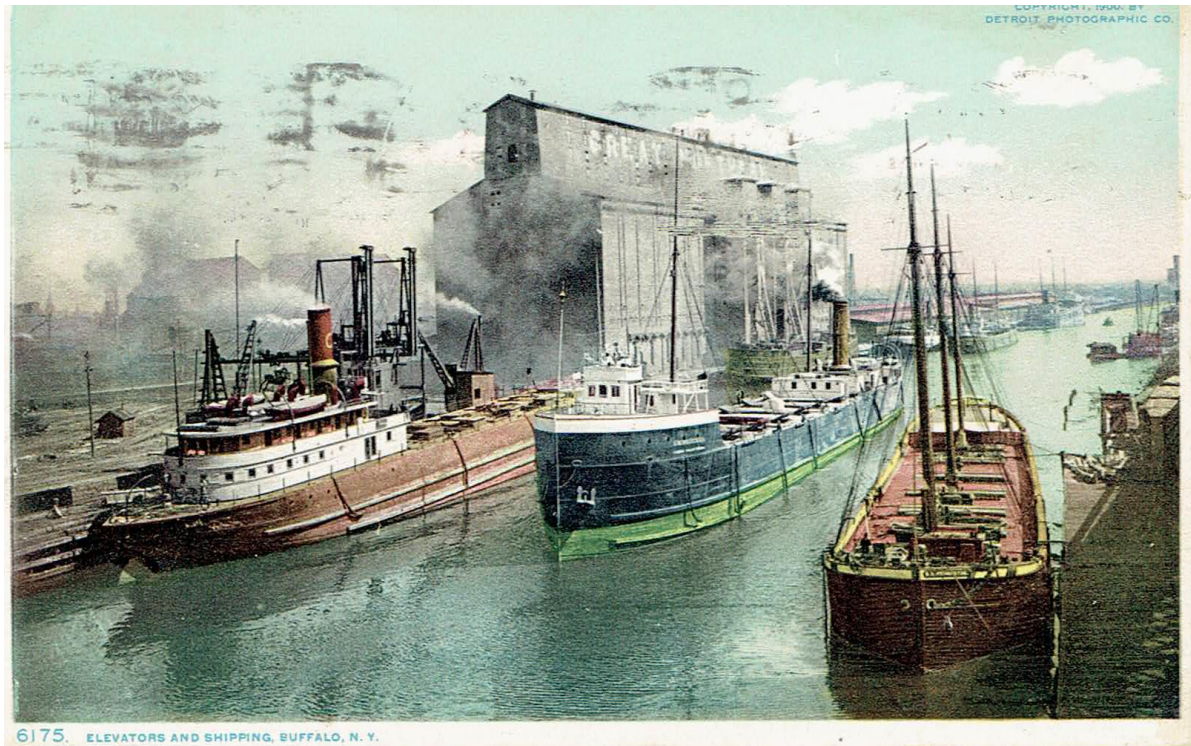

FIGURE 1.6. “Elevators and Shipping, Buffalo, NY (Postcard, Detroit Publishing Company, 1900).”

A ready availability of ship-building timber, among other factors, retarded the adoption of ferrous hulls in the Great Lakes bulk trade until the launch of the iron-hulled *Brunswick* in 1881 (Hoyt 2008:4). *Onoko*, built in 1882, is also commonly cited as the first ferrous bulk freighter on the lakes (Wright 1969:5). Regardless of which vessel is officially credited as first, they were vanguards of a wholesale change in vessel construction on the lakes. The last two decades of the nineteenth century marked a period of rapid economic transition on the Great

Lakes, of which changes in ship design, including the rise and fall of the whaleback, were only a small part.

CHAPTER 2: TRADE AND CIVILIZATION MOVE WEST

In the new world lies a cluster of inland seas, matchless in extent, about which has been growing for three centuries a new civilization, surpassing in splendor and in might the sea-girt empires of the past. Upon these Great Lakes are fleets that excite the wonder of the world. Commerce has here established a new domain, developing in recent years, and the future of which no man dares to measure by existing standards. Cities, peopled by a progressive and dominant race, have sprung up along the shores of these Great Lakes and attained conspicuous eminence and wealth (Mansfield 1899[1]:1).

In gauging the success or failure of whalebacks, context will be everything, thus it will be necessary to have some understanding of the economic and cultural landscape of the Great Lakes region in the second half of the nineteenth century. Once the stage is set, the players will be introduced, and then the play set in motion.

It will be helpful to define the Great Lakes region, and mention a few points of interest. Although the examples here are generally drawn from the American side of the Lakes, the same patterns will broadly be seen to apply to the Canadian side as well. The term Midwest will be eschewed, as there is no end of disagreement as to what it actually refers. Generally, the Great Lakes region can be defined as the coastlines of the lakes themselves, as well as their watersheds. The Great Lakes have two heads, at Chicago and Duluth, and one natural outlet, the St Lawrence River. The opening of the Erie Canal in 1825 (later part of the New York State Barge Canal) created a second artificial outlet, at least as far as commerce is concerned, linking Lake Ontario at Oswego with the Atlantic by way of the Hudson (Mansfield 1899[1]:188). The Great Lakes are conventionally divided into the Upper Lakes, Superior, Michigan, Huron; and the Lower Lakes, Erie and Ontario, separated by the Detroit/St Clair River System (Figure 2.1). Before the

construction of artificial locks and canals, Lake Superior was separated from Lake Huron by the rapids at Sault Ste. Marie; Lakes Erie and Ontario were separated by the Niagara River and Niagara Falls.



FIGURE 2.1. General Map of the Great Lakes. (Wikimedia Commons. Accessed 24 November 2015 <https://en.wikipedia.org/wiki/File:Great-Lakes.svg>).

To the east, the Great Lakes are bordered by the traditionally industrial Northeast and Mid-Atlantic regions of the United States. To the west, they border the ore ranges of Minnesota, Wisconsin and Michigan, and the fertile farmland beyond. Although a considerable variety of commodities have been shipped by the Lakes over their recorded history, from the fur trade carried on by canoe-borne voyageurs to the occasional massive green-energy-generating windmill now seen travelling in sections on the back of a salt water freighter today, a few economic factors stand out as dominant in the region in the late nineteenth century.

By the 1760s three industries were prominent in the nascent Great Lakes trade: fishing, copper mining, and fur trapping (Mansfield 1899[1]:116). It will be appreciated that the latter two commodities share something in common. Both were high in value relative to their bulk. Copper mining remains an active industry in the region, and if fur-felt top hats have gone out of vogue, well, that is so much the better for the beavers. As Mansfield writes, “The principal articles of shipment to Buffalo in 1830 were corn, fish, furs, whisky, lumber and shingles” (Mansfield 1899[1]:182). Thus, some seventy years later, trade has shifted towards bulkier commodities, but there is still something of a frontier aspect to Great Lakes trade. These are products of an agrarian economy, a shipping manifest that, with minor alterations, would have been as at home in biblical times as it is here in the early nineteenth century. At any rate, the rise of the bulk carrier was predicated on the rise of even bulkier, lower value per ton commodities moving in staggering quantities: timber, coal, iron ore, grain, and the like. Arguing in 1891 for deeper navigable channels on the Great Lakes, Livingstone notes that:

Were [lake shipments for 1890] loaded into railroad trains, the length of the grain and flour trains would be 1652 miles; of the coal trains, 2302 miles; of the lumber and timber trains, 3360 miles; of the iron ore trains, 3892 miles; and of the general merchandise trains, 3000 miles. The total length of the trains would be 14,206 miles or they would stretch more than half way around the globe (Livingstone 1891:5).

This change in trade was not merely a change in scale; it was part of a process of total reorganization of the American economy, a tremendous surge towards industrialization and mass-production.

Probably the most definitive factor in the rise of the Great Lakes region, and expansion of the United States as a whole, in the second half of the nineteenth century was steel. The steel industry conjured forth bridges, railroads, plows, barbed wire, skyscrapers and a thousand other

things. Steel both fueled and enabled the nation's westward expansion and rapid industrialization. The historical center of the American steel industry is Western Pennsylvania. The undisputed capital of steel country was Pittsburgh, home of Carnegie's foundry operations, and later of U.S. Steel, and not by accident. Pittsburgh is strategically placed in such a way as to have ready access to the three critical raw materials of steel manufacturing. Pennsylvania and West Virginia produced ample supplies of high quality bituminous coal. The entire Northeast is well-supplied with limestone, used in the steel-making process to remove impurities. Finally, although historically iron ore was mined in the Mid-Atlantic, by the end of the nineteenth century, the ranges in Minnesota, Wisconsin, and northern Michigan had become the nation's primary suppliers of iron ore. It will be readily appreciated that the Great Lakes form a natural transportation link between the northern ore fields and the foundries of the Northeast. Further, Pennsylvania was historically the heart of the nation's rail network, providing high demand for steel rails. It should also be evident that in an industry where both the raw materials and the finished product are massive and bulky, a location with ready access to supplies and transportation routes is highly desirable (Garreau 1982:59-60; Morris 2005:122-124,128-133).

As Table 2.1 shows, ore shipments from the northern ranges rose steadily and convincingly, and much of this tonnage travelled by bulk carrier. A cursory survey of America's major industrial cities, what is now colloquially known as the Rust Belt, reveals a marked concentration on the shores of the Lakes, cities such as Buffalo, Cleveland, Detroit, Gary, and Chicago. By the 1890s, Cleveland had become the greatest shipbuilding center on the continent (Mansfield 1899[1]:300). Detroit was once known as the Paris of the Midwest (Vachon 2009:35). And Chicago, America's "Second City" was the *de facto* capitol of an inland empire,

the center of gravity of the vast watershed bordered by the Rockies to the West and the Appalachians to the East, as Mansfield declaims:

Chicago is the favored child of the Great Lakes The neighbors of the future metropolis were more comely in appearance, more decently garbed, but the matchless location of Chicago as the point of greatest distance for lake traffic towards the growing West, gave it a power that outweighed all other considerations (Mansfield 1899[1]:337).

Year	Shipments of Iron Ore in Tons
1854	3,000
1870	856,245
1880	1,944,960
1881	2,318,821
1882	3,000,213
1883	2,318,821
1884	2,517,462
1885	2,468,446
1886	3,577,286
1887	4,764,587
1888	5,063,883
1889	7,272,744
1890	9,010,967
1891	7,073,967
1892	9,080,684
1893	6,074,888
1894	7,759,753
1895	10,441,462
1896	9,950,541
1897	12,473,032
1898	14,037,247
1899	18,240,716
1900	19,167,100

TABLE 2.1. Condensed from “Total Annual Shipments of Lake Superior Iron Ores by Ranges” from *The Iron Ores of Lake Superior* (Crowell and Murray 1927:96-97).

By 1900, only two ports outranked Chicago in volume of tonnage handled, London and New York (Mansfield 1899[1]:341). Of the ports handling the most tonnage in the U.S. in 1897, three of the top five were located on the Great Lakes: metro-Chicago, Duluth-Superior, and Buffalo, with receipts in excess of 10,000,000 tons each, with only New York and Philadelphia in competition (Mansfield 1899[1]:361).

It is useful perhaps, to think of the Great Lakes district as a nation to itself, one that rose out of America as a whole, having a distinct culture and economy, and which is now, and has been for some decades, receding back into the general fabric of the country as different eddies drive the flow of wealth and humanity within our nation and America’s steel age recedes into

memory, our heroic era of foundry and furnace now ceded to other nations where the first harvests of the industrial revolution are just now being reaped.

Coal, the second key factor in steel-making, was transported on bulk freighters in significant quantities, but tended not to be the key driver in lake trade. Although steel production was a major industry throughout the region, the center of gravity was Pennsylvania, which had easy access to coal and limestone. Thus, iron ore tended to be shipped down the lakes to the location of these other two commodities, rather than the other way around. When coal was shipped, it was shipped up-bound, as a return cargo. In the 1890s, the annual tonnage of coal shipped on the Lakes tended to be about a third that of iron ore, although annual figures varied somewhat (Mansfield 1899[1]:193).

Another key commodity in Great Lakes trade is grain. The westward expansion, abetted by the rise of steel, opened the fertile plain states.

Agricultural wealth in the west owes its success to the Great Lakes. Washington perceived the need of transportation facilities to the interior of the country, as it existed more than a century ago, and he advocated and encouraged the construction of waterways; but for years the energies of the land proved unequal to the task. Farming languished beyond the Alleghenies until the completion of the Erie Canal. Then was given an impetus to Western emigration which continued until the region of the lakes was populated; and when settlements penetrated still farther into the interior, railroads were constructed to unite the farms and the Great Lakes. To-day (sic) the western farmer with his teeming acres, located some fifteen hundred miles or more inland from the seacoast, owes to the cheap lake freights his ability to reach the markets of foreign lands (Mansfield 1899[1]:3).

Mansfield writes with a grandeur and self-assurance that modern writers seldom dare, and it is left to his modern commentator to rein him in. He neglects one or two salient points, namely: a westward expansion likely would have happened one way or another, Great Lakes or no, given

America's booming population and hunger for arable land; and the not inconsiderable trade route offered by the Mississippi and its tributaries reaching from the heart of the continent to the sea. Nonetheless, his point stands, people flowed west along the Lakes, and grain flowed back. Although the grain trade was important, it will immediately be recognized that it was an essentially seasonal trade. As the bulk trade developed, grain constituted a minority, albeit a substantial one, of the tonnage moving on bulk freighters, with Livingstone reporting an estimated 4,846,430 net tons of "flour, grain, seeds and milled products" travelling over the Lakes in 1890. He reports iron ore shipments of nearly double that tonnage for the same year, 9,133,963 net tons (Livingstone 1891:5).

Lumber was a major commodity in Lake trade, but it was in decline by the end of the nineteenth century. As Dr. George G. Tunnell described:

With the depletion of the forests of white and norway pine contiguous to the lakes and near the rivers flowing into the lakes, the transportation situation has been radically altered. As the lumbermen have been forced to go farther and farther into the interior, the railroads have found it correspondingly easier to compete with the lake carriers As the cost involved in moving the logs from the remote districts to the lake shore is often sufficient to prevent such movement, the logs are sawed at mills located at interior points. From these interior mills, the lumber generally goes to market by rail, for the cost of shipping by the combined rail-and-water route with its charges for transshipment is greater than that by the all-rail lines (Tunnell 1898:95).

Where in 1885, 695 million board feet of lumber had moved by lake, compared to 149 million by rail, in 1895 only 136 million board feet moved by lake and 393 million board feet by rail. The overall pattern was towards a diminishing in both total lumber shipped and in the relative share shipped by lake (Tunnell 1898:96). The carriage of lumber on the Great Lakes was increasingly

separate, as loading and unloading technologies became more mechanized and focused on more granular materials such as grain and ore.

Oil also enters into our story. The original petroleum boom was born in Western Pennsylvania, in 1859, at Drake's Well outside of Titusville, and left its mark in the names of spring-up towns like Oil City and Pithole (Morris 2005:17-18; Chernow 1998:74-86). Oil was never a major lake freight commodity. For the most part, it was shipped by train or pumped by pipeline to eastern ports (Chernow 1998:110,171-172). It is relevant here, though, as a source of wealth. John D. Rockefeller's Standard Oil, which monopolized the industry, was originally captoled in Cleveland (Chernow 1998:77-78). Rockefeller and his vast fortune became entangled with McDougall's whalebacks, and were instrumental in both their rise and their fall (Daley 2000:28-31,40,51-58,69; McDougall 1932:32-33,40-42,47-49).

Inseparable from this tremendous growth in trade was a similarly rapid growth in population along the shores of the lakes, as Table 2.2 shows, surging far ahead of even the booming growth on the Eastern Seaboard.

Thus, in the final two decades of the nineteenth century, the period in which the whalebacks were built, some definite observations about trade on the lakes can be made. Steel production was the most substantial driving force in expansion, both as a commodity, and as a technological accelerator. Iron ore was the most important freight on the lakes, although by no means the only one. It would be expected that the demands of the ore trade would shape bulk carriers even if they sometimes carried other cargos. Thus, the bulk carrier became, essentially, an iron ore carrier, which was conveniently suited to sometimes carry other cargos. Also of note is, that of the industries outlined above, only the iron-ore interests owned their own ships, the balance being operated by independent lines (Mansfield 1899[1]:443). This probably reflects the

fact that steel production would require a greater accumulation of capital than the other industries mentioned above, and thus be naturally inclined towards more monolithic, vertically integrated structures. At any rate, it might be expected that the ore trade would be the primary driver of bulk carrier development, and further, that in the case of those vessels built or owned by the steel industry, command decisions might sometimes overshadow market forces.

<u>City</u>	<u>1850</u>	<u>1860</u>	<u>% Change</u>	<u>1870</u>	<u>% Change</u>	<u>1880</u>	<u>% Change</u>
Boston	136,881	177,840	30%	250,526	41%	362,839	45%
New York	696,115	1,174,799	69%	1,478,103	26%	1,911,698	29%
Pittsburgh	46,601	49,221	6%	86,076	75%	156,389	82%
Cleveland	17,034	43,413	155%	92,829	114%	160,416	73%
Detroit	21,019	45,619	117%	79,577	74%	116,340	46%
Minneapolis	0	2,564		13,066	410%	46,887	359%
St. Paul	1,112	10,401	835%	20,030	93%	41,473	107%
Chicago	29,963	112,172	274%	298,977	167%	503,185	68%

TABLE 2.2. Population growth in selected U.S. cities, as compiled from census data.

The Great Lakes region was a locus for a remarkable accumulation of capital, and must have seemed at the time to have had the potential for unlimited growth. A road trip to Gary, Indiana or Detroit, Michigan will satisfy the reader that that rising sun is now to all appearances a setting one, but it must have been heady times while it lasted. It must have seemed on that steel frontier that any height was attainable, if only a man had the vision and drive to seek it out.

Infrastructure

At first blush, it might appear that railways and waterborne transportation would be in direct competition with each other, and to a certain extent this is true, but they also complement

each other. Stated another way, transportation is not necessarily a zero-sum game. During the booming development in the Great Lakes region in the latter half of the nineteenth century, both would have abetted the population growth seen in Table 2.2 and the economic growth that went with it. The completion of the Erie Canal in October of 1825 further encouraged expansion, providing a direct artery between the Upper Lakes and the industrialized East Coast (Mansfield 1899[1]:222; Plumb 1911:19), and, as Plumb states, inaugurated “a new era on the Lakes” (Plumb 1911:80). The shift towards the use of steel as the primary bulk freighter shipbuilding material on the Lakes during the 1880’s, a technology which had already been pioneered and mastered decades earlier in other areas, most notably the British Isles (Bowlus 2010:118-120), meant that effectively there were no longer inherent constraints on how big a laker could be built. The constraints were all external, and related to choke points in the Lake infrastructure. This is deeply germane to the discussion at hand. Nearly the entire whaleback experiment was conducted during a decade and a half, when the limiting factors of bulk freighter construction shifted from the structural constraints imposed by the properties of wood to the external constraints of chokepoints in Lake infrastructure. Fourteen years passed between the construction of the first ferrous bulk freighter on the lakes, *Brunswick* in 1881 (Devendorf 1995:58), and a critical change in the infrastructure of the Great Lakes, the opening of the new 900’ Canadian Lock in 1895 and the 800’ (American) Poe Lock in 1896 (Mansfield 1899[1]:244). Although, over time, there was a general trend of infrastructure development, several watershed moments stand out.

Sault Saint Marie, the rapids at the head of the St Mary River, through which Lake Superior empties into Lake Huron, was the critical chokepoint limiting access to the ore fields bordering Lake Superior (Plumb 1911:31-33; Kelton 1888:6). There are other narrow points, of

course, most notably the shallow and muddy Lake St Clair, and the winding Detroit and St Clair Rivers, but the Sault, a cascade of white water over hard granite bedrock, presented by far the most formidable engineering challenge (Bowlus 2010:62-73). Even today, the main physical limiting factor in the size of Great Lakes bulk carriers is the Sault locks (Thompson 1994:187-189). A lock is a section of a canal with doors at either end. It can be drained or filled at a controlled rate. It functions as an elevator and allows ships to safely bypass rapids or other sharp changes in elevation. Thus, a ship can step up or down between bodies of water of different elevations (Kelton 1888:8-13).

In 1797, the first lock was built at the Sault, colloquially referred to as “the Soo.” It was a modest affair, 38’ long and 9’ wide, with a thirty inch draft. It was sufficient for canoe traffic, but not much more, and was destroyed in the War of 1812. In the ensuing four decades, trade and resource exploitation in the Lake Superior district developed slowly. A few small ships were built on the lake, or dragged there overland, but the fact that cargos still had to be off-loaded and trans-shipped at the Sault was a tremendous check on both development and the flow of goods (Dickinson 1981:xii).

In 1837, the need to build a new Sault canal became a matter of congressional debate, but, largely for political reasons, ground was not broken until 1853. This, the first large scale lock, generally referred to as the Harvey lock, opened to traffic in 1855. The Harvey lock was named after the engineer chiefly responsible for its design, a naming convention which would be applied to subsequent locks (Dickinson 1981:xiii-xiv; Kelton 1888:7-8).

The scale, in human terms, of this project should be born in mind. The Sault canal was dug with mid-nineteenth century technology, which meant picks and shovels, wheel-barrows and sweat. The Sault canal and Harvey lock cost a grand total of \$1,812.96 (Dickinson 1981:122), a

considerable sum. By means of comparison, a laborer on the project earned \$1.10 per day (Dickinson 1981:62), and, in the 1850s, before the wide advent of labor-saving machines, it can be safely assumed that most of this expenditure equated, in the end, to labor, whether it be shoveled earth or quarried facing stone hauled to the work site by creaking schooners. Add to this equation a minor cholera epidemic at the work site (Dickinson 1981:80), and a fairly grim picture emerges. All of this happened at what is still today a frontier, closer to the pole than the equator, where winter stays late and comes early. It is a testament to the sacrifices our forebears made to build a nation, but it is also an illustration of the tremendous market forces which aligned on an empty quarter to carve a pathway for the lifeblood of an epoch, steel. Steel built a new world and any sacrifice it demanded was laid at its altar, readily and without equivocation.

In the ensuing decades, it became evident that more capacity would be needed. Subsequent locks were built on the American side of the rapids in 1881, 1896, 1914, 1919, 1943, and 1969, as well as a Canadian lock completed in 1895. Each represented an increase in capacity (Bowlus 2010:97-98,112-114,196-197; Dickinson 1981:xiv). Of interest here are the Canadian lock and the first three iterations of the American locks: 1853, 1881, and 1896:

- The Harvey locks of 1853 measured 350 feet by 70 feet, with a design draft of 11 1/2 feet, and a 9 foot lift (Kelton 1888:7).
- The Weitzel lock of 1881, constructed next to the Harvey lock, measured 515 feet by 60 feet, with a draft of 16 feet, and marked a substantial increase in capacity (Kelton 1888:8).
- The first Poe lock (Figure 2.2), completed in 1896, replaced the Harvey lock and measured 800 feet by 100 feet, with a draft of 21 feet (Mansfield 1899[1]:244).
- The Canadian lock, completed in 1895, measured 900 feet by 100 feet with a depth of 20

feet (Dickinson 1981:xiv; Mansfield 1899[1]:247).

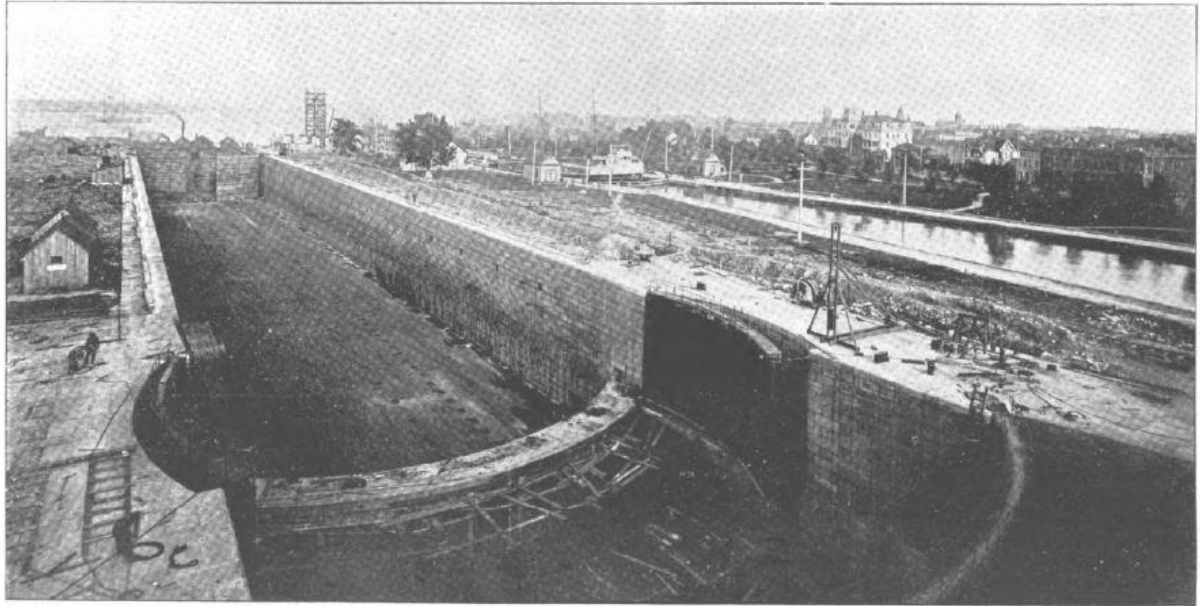

Hughes Bros. & Bangs, Syracuse, N. Y., Contractors.

THE NEW AMERICAN LOCK, AT SAULT STE. MARIE, MICH.—NEARING COMPLETION, MAY 1, 1896.

219

FIGURE 2.2. The Poe Lock at Sault Ste. Marie nearing completion, from the *Blue Book of American Shipping, 1896* (Mulrooney and Barton 1896:193).

Each time the Sault Locks were rebuilt, bulk carriers were built to larger dimensions in response. This was a matter of economy of scale. Bulk carriers could be built larger, and, as it were, carry more bulk. Any number of more or less fixed expenses in both construction and operation would stay constant or near constant. A bulk carrier that was, for example, twenty five percent larger than the preceding generation would simply have more of the least expensive part of the ship, the long, empty parallel mid-section. It would still require roughly the same amount of all the more expensive parts: bow and stern sections, engines and propellers, gear and ground tackle, captain and crew. This is a simplification, of course, but a modest one. Bigger ships meant incremental gains in efficiency, and thus in profitability (Bowlus 2010:145; Thompson 1991:22).

Further encouraging the trend towards larger ships, improvements in shipbuilding technology made their way to the Great Lakes in the last decade of the nineteenth century, making the construction of much larger vessels substantially cheaper and easier. The most notable of these technologies were gantry cranes and the switch from hammered rivets to pneumatically driven rivets. The former allowed much larger elements of hull structure and machinery to be manipulated and put in place. The latter resulted in substantial savings in the cost of labor. Between improvements in infrastructure which could accommodate larger hulls, and advances in technology making their way to yards on the Great Lakes, the cost of building ships fell 30 to 40 per cent per ton in the last fifteen years of the nineteenth century (Wright 1969:13-16).

Thus, we might divide Lakers into generations, based on the infrastructure within which they operated. Each new, improved iteration of the Sault locks, the primary chokepoint in the bulk trade would beget a new generation of ships. Older ships would be comparatively disadvantaged. In the freshwater environment of the Lakes, where a steel hull can last indefinitely, and with a rebuild can be lengthened or modernized should the need arise, some commercial ships thus have celebrated a century of service, with hull construction, and all ancillary systems, power plant, navigation equipment and the like being readily updated. Thus, the most meaningful distinction between bulk carriers, assuming no defect in design or construction, becomes size. With a laker's large cost of construction, it would not be retired as soon as a new generation came into service. As long as trade remained steady and there were plenty of cargos to be had, it could remain profitable to run.

The considerable cost of constructing a large bulk carrier would have discouraged builders from getting too far ahead of themselves in terms of speculative building. An owner

might conceivably time a new larger ship to launch at the same time a new larger lock was ready to open, but even that would be risky, and there is no evidence that it was ever practiced. If the opening of the new lock was delayed for any reason, the yard would be left with an idle ship – a very large investment making no return.

Patents

Another factor worth consideration is the overall intellectual property climate during the period in question, especially as concerns patents. The patents system is relatively modern, having originated in the Renaissance (de Camp 1961:15). American patent law was established by the Constitution in Article 1, section 8, which reserves to Congress the power “To promote the Progress of Science and useful Arts, by securing for limited Times to Authors and Inventors the exclusive Right to their respective Writings and Discoveries” (Hamilton et al. 1787:1:8). However, the details as to how this law was to be administered and enforced took some decades to iron out.

De Camp identifies a heroic age of American invention, dating from 1836 to 1917, an “age during which the patent laws were well enough organized, and conditions were favorable enough to inventors, so that those with meritorious inventions had a fair chance of success” (De Camp 1961:41). This Age is bracketed by the reorganization of the U.S. Patent Office on the one hand, and on the other, America’s entry into the First World War, a watershed moment which marked the increasing dominance of invention and the patent process by corporate research and development departments, effectively shutting out, in most cases, the independent inventor from the access to capital needed to bring his invention to market. While the independent inventor still exists, the bulk of industrial progress is dominated by large corporations. Khan notes that “During [the early twentieth century] formal college education,

human capital accumulation, and financial capital mobilization through corporate ties became more important” (Khan 2005:12). As laid out, the American patent and copyright system, in contrast to its European counterparts, was designed to promote an egalitarian concept of intellectual property (Khan 2005:8). This has been cited as a key factor in the rapid industrial and economic growth in nineteenth century America (Khan 2005:2-5).

Thus, another link in the chain of circumstances leading to the development, and for a time, success, of McDougall’s whalebacks was the particular intellectual property environment during the Gilded Age. In an earlier period, patents were difficult, if not impossible to legally enforce, as in the case of Eli Whitney and his celebrated and serially pirated cotton gin (De Camp 1961:29-30). Without strong intellectual property protections, a radical innovator in a capital intensive field like shipbuilding would have had a difficult time securing financial backing. Any backer would effectively be underwriting the risk without any reciprocal guarantee of exclusivity of benefit. In a later age, an inventor with no formal scientific or engineering training to speak of, such as McDougall, would have a decidedly difficult time rewriting the accepted wisdom of shipbuilding on gut instinct. Among Alexander McDougall’s other accomplishments, we can list being in the right place at the right time.

Growth and Consolidation

The nineteenth century witnessed a complete restructuring of the American economy. An agrarian backwater reinvented itself as a world leader in industry in the short space of a century (Khan 2000:5). We have focused mainly on the Great Lakes region, but it will be worthwhile to comment on certain larger trends and macroeconomic events.

The nation’s railroad network is largely a product of the nineteenth century. The overall pattern of railroad expansion was one of growth in advance of demand and operation on low

marginal returns on investment. This provided both a framework and an impetus for growth and commerce (Morris 2005:141-150). It might be expected, at first glance, that railroads and Great Lakes freighters would compete with one another directly. That, however, assumes market conditions approximating a zero-sum game, where growth in one transportation sector would automatically mean less business for other modes of transport. A more nuanced appraisal would suggest that Lake shipping and rail shipping complimented each other, that each was better adapted to certain types of cargo, and that each fed the other by fueling growth generally.

Broadly speaking, the antebellum period saw the rise of two industries which had hitherto only been of minor importance: oil and steel. Rockefeller entered the refining business in 1863 (Chernow 1998:77). By 1879, his Standard Oil controlled 90-95% of the refining capacity in the country (Morris 2005:152), and having rapidly achieved a horizontal monopoly, was continuing to integrate vertically. A similar process was unfolding in the steel industry. By the 1880s, Carnegie Steel, although well short of a monopoly, had attained a strong position of market dominance, and was a perpetual threat to its few remaining rivals (Morris 2005:132-133).

The oil and steel industries are only the two most conspicuous examples of a process that was unfolding across the American industrial landscape: cut-throat competition, culminating in the winner acquiring and consolidating the loser. The process repeated itself in industries as varied as tin-plate to biscuits (Morris 2005:252).

This unparalleled experiment in laissez-faire capitalism had any number of wide-ranging effects, from the rise of the labor movement, to the Sherman Anti-Trust Act and subsequent government regulation of business (Morris 2005:194-196,216-219). Two in particular, however, stand out as relevant to this discussion. First, it put fortunes in the hands of businessmen that would confound the avarice of kings. In the case of John D. Rockefeller, some of this wealth

was reinvested (Daley 2000:5-8). When Mr. Rockefeller took a stance in an industry, it was likely to have wide repercussions, as we will see with McDougall and American Steel Barge Company in Chapter 4. Second, the slash and burn path to market domination was the bane of bankers, who were left to clean up the financial mess. Most fully embodied by J.P. Morgan, this move to channel capitalism's more chaotic expressions away from what Morgan called "ruinous competition (Morris 2005:xii)" led to the rolling up of the steel industry into U. S Steel, and the consequent consolidations in Great Lakes shipping (Morris 2005:254-266; Wright 1969:135-146).

The Cyclical Picture

As has been noted, McDougall had the impeccable good timing to be active during a period that was favorable to the independent inventor. There is at least one other respect in which he was fortunate enough to be on the scene at the right time, that of the larger economic picture.

Although the latter half of the nineteenth century was characterized by overall explosive growth, this growth was by no means a steady unwavering line from point A to point B. There were a number of recessions, although it is tempting to revive the Nixonian euphemism "growth correction" (Galbraith 1977:102), as it seems apt in at least this one case. It was as if the American economy was pausing for breath in between lurching sprints. The pattern should be familiar to anyone acquainted with any of the modern market "bubbles": over-exuberance later reined in by a loss of confidence and a subsequent collapse of investments and contraction in lending. If anything, in the absence of a central banking authority, the recessions of the Gilded Age were more cyclically regular, more systemic, and more severe (Galbraith 1976:35-38).

That being said, the 1880s were relatively placid, and it is probably no coincidence that this is the decade in which McDougall and his whalebacks enjoyed their portion of success. The preceding decade, the 1870s had seen strong growth, in the neighborhood of 4.5 to 6 percent annually, but steeply falling prices had radical effects across the board, including doubling the rate of business bankruptcies per year throughout the decade. By the 1880s, the economy had reached a more comfortable state of equilibrium, which was to persist until the bank panic of 1893(Morris 2005: 102-109). This panic, as shall be more thoroughly explored later, was a key part of the chain of events which forced McDougall out of the American Steel Barge Company and out of the business of building whalebacks.

Summary

Innumerable factors combine to create the historical moment, solar eclipses, the price of tea in China, and the plans of men. There can never be a full enumeration of all the factors at play, but the ones outlined above are preponderant in the circumstances surrounding the rise and fall of the whaleback. A variety of factors, notable among them the growth of the steel industry, had led to greatly expanded trade and an influx of capital into the Great Lakes region. This made it an advantageous time to enter the shipbuilding industry.

The nature of patent law in late nineteenth century America and maritime industrial practice towards patent holders were favorable to the lone inventor. Perhaps more so than at any other time and place, inventors were able to develop products and bring them to the market and reap the financial benefits of doing so.

At the same time, improvements in the infrastructure of the Great Lakes and connecting waterways, most notably the canal and locks at Sault Ste Marie, effectively reset the ground rules for bulk trade. This happened several times, but the relevant examples are the construction of the

new locks at the Sault in 1881 and 1895/96. Each time the Sault Locks were rebuilt, it represented an opportunity for shipbuilding to leap forward.

As if this weren't enough, the conversion of Great Lakes shipyards from using primarily wood to primarily steel was another destabilizing element favoring newcomers and innovators. Although ferrous Lake freighters ended up resembling wooden Lake freighters in most respects, this was not necessarily a given. A change to a radically different new technology had the potential to carry with it the wholesale reinvention of the vessels involved.

The final element was the overall cycle of boom and bust which characterized the overall economy during the period. It is tempting to think of the Gilded Age macro-economy as manic-depressive. During periods of economic expansion, as in the expansion beginning in 1881, money flowed freely, and new undertakings found it easier to acquire capital. During contractions, as in 1896, we would expect the business mood to be more saturnine. Money would gravitate towards safe investments and proven strategies. Underlying this in 1896 was a wave of industrial consolidations which was by that point reaching the bulk freight industry on the Lakes.

Men and ideas often find their way forward through adversity. The story ahead will focus on McDougall and his partners, and on the whaleback and contemporary bulk carriers. This, however, is a large piece of the puzzle: McDougall launched his first whaleback in 1888 and that was a good year to be building something new and different in the bulk trade. McDougall launched his last whaleback in 1896 (Table 1.1; Table 1.2). Had he been ready, in terms of innovation, capital, and personal connections, whalebacks might have surged ahead on the back of the 1895/1896 canal expansions. However, the stars were not as perfectly aligned as

they had been a decade before, and we shall see that McDougall would have needed to play his cards more cannily than he did.

CHAPTER 3: ALEXANDER MCDUGALL

Our readiest source for information on McDougall himself is his autobiography, especially for his early life (McDougall 1932). He composed it in his old age for the benefit of his family, and it is charmingly unburdened by self-deprecation and doubt. His surviving correspondence is almost exclusively related to business matters, and while it is useful in tracing the fortunes of the American Steel Barge Company (American Steel Barge Company 1885), it is less so in sounding out McDougall's character and motivations. Contemporary accounts are of the glossy "Who's Who" variety, connect him closely with whalebacks, and tend to be somewhat hagiographic. In Mansfield's *History of the Great Lakes*, Captain McDougall is praised for his "ability, perseverance, a consummate knowledge of business affairs, untiring energy, and, above all, unerring judgment (Mansfield 1899[2]:3)." Modern authors who have attempted to render him in more depth seem to have resorted to somewhat more supposition than the documentary record strictly supports (Frew 2008). Thus in writing about the man, we have the image of himself he projected publicly, but little evidence for any other facets of his exist.

Photographs of McDougall are similarly scarce. In one extant example he is of indeterminate height, with a strong, square-shouldered build. His narrowed eyes stare directly back at the lens of the camera; he seems wary, alert, or perhaps this is just a trick of the light (Figure 3.1).

AMERICAN STEEL BARGE COMPANY, WEST SUPERIOR, WIS.



THE American Steel Barge Co. has a ship yard at West Superior with slips sufficient to build a half dozen large steel vessels at one time. In connection with the ship yard is the largest dry dock on the lakes. Application was filed for the first patent on the whaleback form of vessel March 9, 1880, and was granted May 24, 1881. It was, however, nearly seven years later that the first whaleback, the 101, was turned out from the head of the lakes. It was brought down the lakes and attracted wide-spread attention, being placed in the Cleveland dry dock for minor repairs and inspection. The aim was to produce a cheap vessel or barge by leaving off all unnecessary upperworks. In the past eight years, thirty-seven vessels of the whaleback type have been

built at West Superior, including the passenger steamer Christopher Columbus; and the City of Everett was built on the Pacific coast. Several have been built on the Atlantic coast.

FIGURE 3.1. Portrait of Alexander McDougall from the *Blue Book of American Shipping*, 1896 (Mulrooney and Barton 1896:193).

Early Life

McDougall was born in 1845 into a poor family on the Scottish Island of Islay. “All the folks on the Island of Islay were poor,” he writes, “because of the oppression dealt to the tenants by wealthy landlords, people were leaving Scotland by the thousands in those days” (McDougall 1932:4). He seems to have been exceptionally well-regarded by those who worked for him later in life (Wright 1969:53), and we might surmise that his early experiences with poverty gave him an egalitarian outlook on life which deeply influenced his relations with labor. Throughout his autobiography, he emphasizes the virtues of hard work and frugality (McDougall 1932:5,6,-9,12-13,17,19,25-27). In 1854, his family immigrated to Canada in what he describes as “a miserable voyage,” on a small sailing ship, settling in the village of Nottawa in the vicinity of Collingwood, Ontario, a town on Georgian Bay (McDougall 1932:4-5). His father found work

as a sawyer, but was fatally injured in a mill accident in 1855 (McDougall 1932:5-6). At the age of ten, Alexander, the eldest child, became responsible for helping to provide for his family, which he did by fishing and working at odd jobs for local farmers and craftsmen. His description of the times is laconic, but it is apparent that for the McDougalls it was a life of want and worry on this isolated frontier and the account evinces the reader's empathy all the more for his stiff upper lip (McDougall 1932:5-7). At sixteen, Alexander apprenticed with a blacksmith, saying of the experience, "the knowledge that I gained about working iron and steel was worth a great deal to me in after life among larger works" (McDougall 1932:8). In July of 1861, he "ran away" and shipped as a deckhand on the steamer *Edith*. He tried to enlist with the Union Army, but was turned away on account of his youth, and finished the season on the *Edith* (McDougall 1932:8).

I sailed all that summer from Collingwood to Chicago. On our last trip to Collingwood I brought from Milwaukee to my home, the greatest treasure of my life, which helped to make that little family in the log shanty most happy. This treasure was a new cook stove with a high oven, a full sack of yellow corn meal, a full sack of white corn meal, and a small box of silver coins which I had earned blacking passengers' shoes; also a rifle with which I could shoot some of the game which was so plentiful in the winter.

Often since then I have made in a single year what seemed a fortune to me, but was never so rich in my life as when I took the new stove and the meal and the dimes back to my mother. It was the first time since the family left Port Ellen in Scotland that we really had all we wanted to eat (McDougall 1932:9).

The Formative Years

Even for those not terribly interested in the development of the whaleback steamer, Alexander McDougall's autobiography makes for fascinating reading for several reasons. McDougall was an excellent raconteur, presents himself as a bold and self-assured risk taker, and

is an invaluable observer of the transition from sail to steam and from wood to steel. His narrative voice is clear and unique, and imparts a novelistic quality to his writing.

“From 1861 to 1880 I followed the Lakes as a deckhand, porter, second mate, mate and pilot, and then captain,” McDougall writes (McDougall 1932:9). When McDougall later transitioned to shipbuilding, it was on the practical experience that he gained working on the Lakes, based on decades of observation and rumination. Although he had no formal experience in naval architecture, he had a grass roots understanding of the demands of Great Lakes trade, and several business ventures under his belt (McDougall 1932:10-31).

In 1864, McDougall began shipping on vessels working the burgeoning Lake Superior trade. At that time, the region was a sparsely populated frontier, largely without charts and aids to navigation. Development of the region was driven by copper and iron ore mining, a trade that at the time was in its infancy, but was experiencing strong growth because of the material demands associated with the Civil War. McDougall worked freight and passenger steamers, in what must have been brutally demanding conditions (McDougall 1932:11-13). At the time, twelve hour days were the baseline for maritime trades, and the demands of loading, unloading and ship-handling would often infringe on “off-time.” Piloting on the confined waters of the Great Lakes could be more taxing than on the open sea: rocks, shoals, and an unfriendly shore were never far enough away to be put out of mind. The contemporary emphasis on steaming ahead at speed despite inclement weather or decreased visibility is well documented (Thompson 2000:55-56,77,331). Thus, the Great Lakes watch-keeper must have often found himself suspended between the Scylla and Charybdis of overwhelming fatigue on the one hand and dread of unseen perils on the other.

McDougall rose quickly through the ranks, through the hawse pipe as it were, working his way to the quarterdeck without the benefit of formal training. By 1870, McDougall had risen to become a captain in the robust lake trade and witnessed firsthand the transitions from sail to steam and wood to steel (McDougall 1932:15). The following passage from his autobiography is illustrative:

When I began sailing the Lakes nearly all the carrying was done by schooners under sail and by many big sidewheel steamers.

There was also a fleet of smaller boats that ran from Ogdensburg, N.Y., in the freight and passenger service to Chicago. These boats ran through the canal to the Lakes. They were towed by horses through the canals and by steam tugs through the rivers and in open water they travelled partially under sail. They sailed in fleets and I have seen as high as 200 windbound in one anchorage. Once in a storm I saw forty of them piled upon the beach one after another in the northwest angle of Lake Huron (McDougall 1932:9).

During the Civil war, demand for raw commodities such as ore and grain were strong, with copper prices being especially robust (McDougall 1932:10), although this was rarely mined in sufficient quantities to constitute a bulk trade, and was more often shipped in small lots on passenger and tramp steamers (Thompson 1991:10). After the war, trade tapered off, and although McDougall was by now regularly shipping as a mate, he was sometimes compelled to work odd jobs, such as making flour barrel hoops (McDougall 1932:13).

In 1868, traffic on Superior revived with the construction of the Lake Superior & Mississippi Railway, spearheaded by robber baron Jay Cooke. The Lake Superior & Mississippi was intended to connect Duluth, at the head of Lake Superior, with the nation's railway network in general. Boom times on Superior persisted until the collapse of Cooke's Northern Pacific Railroad in 1873 (McDougall 1932:13-17).

In the winter of 1870-1871, now employed by the Anchor Line, McDougall helped to build three of the first iron vessels on the Lakes, the passenger steamers *China*, *India*, and *Japan*. McDougall does not specify what his role in the shipyard was, but given his vigorous personality, it was doubtless an active one. Mariners and shipwrights are sometimes at odds in these situations. A prudent mariner always seeks the best vessel he can get in all regards; a successful shipyard produces the best vessel it can within the constraints of time and cost. At any rate, when the 325 foot *Japan* was finally fitted out, in September of 1871, McDougall, aged 26, shipped as captain. In the fall of the same year, McDougall built a home at 214 First Avenue West, in Duluth. McDougall continued his association with Anchor Line until 1876, captaining *Japan* during the sailing season, and entertaining himself with odd ventures during the winter, many of them concerning commercial fishing. He had also undertaken an expedition in the fall of 1875 at the behest of the Anchor Line's manager, E.T. Evans to survey the Russian bulk trade, with a mind towards the company's investment in that quarter (McDougall 1932:15-28).

In 1876, McDougall took command of the new passenger steamer *City of Duluth*, which ran between Chicago and the various Superior ports, and in the running of which he appears to have had a relatively free hand. He felt that this position was stable and lucrative enough that he was able to marry, and did so in the summer of 1876 to Emmeline E. Ross of Toronto. In 1880, he took command of *Hiawatha*, a bulk steamer which typically towed the consort *Minnehaha*. He also began to position himself as a ship's agent, chartering and insuring grain cargos, and organizing stevedoring parties, and becoming active in the Duluth Board of Trade (McDougall 1932:28-31).

In retrospect, it is evident that McDougall's life up to that point was positioning him to build whalebacks, especially as he tells it. His early experiences in blacksmithing had given him

a basic understanding of metal-working. His involvement in the construction of *Japan* and his subsequent command of that and other ferrous vessels put him in at the ground floor of iron and steel shipbuilding on the Lakes. Although not an expert in ship-design, he was at least knowledgeable enough to form opinions on what he wanted and communicate them to more experienced naval architects and ship constructors. He was active in, and well positioned to observe the changing bulk trade, with his seafaring career corresponding with the genesis of the modern Lake freighter, and with the introduction of steel in Great Lakes shipbuilding.

McDougall's off-season ventures had given him a taste of venture capitalism, and his years of command on the Lakes had accustomed him to trusting his own judgment and abilities. Finally, he had planted his flag in Duluth, the town strategically located to control the bulk iron ore trade, as well as a large fraction of the grain trade (McDougall 1932:7-31).

The Vessels

In 1888 Alexander McDougall launched his first whaleback barge, *101*. His wife is, apocryphally, said to have exclaimed, "There goes our last dollar," as it slid down the ways, as the investment was entirely McDougall's own. Barge *101* is almost never mentioned without this incident being related as well (Zoss 2007:7; McDougall 1932:32; Frew 2008:34). It had been a launching many years in the making. McDougall recounts:

While Captain of the *Hiawatha*, towing the *Minnehaha* and *Goshawk* through the difficult and dangerous channels of our rivers, I thought out a plan to build an iron boat cheaper than wooden vessels. I first made plan and models for a boat with a flat bottom, designed to carry the greatest cargo on the least water, with rounded top, so that water could not stay on board; with a spoon-shaped bow to best follow the line of strain with the least use of the rudder and with turrets on deck for passage into the interior of the hull.

After demonstrating my idea by models, I could not get anything from ship owners and from captains except comments such as "She will roll over, having no masts to hold her up"; or

“She has no flat deck and bulwarks to keep the waves off”; or
“You call that damn thing a boat, -- why it looks more like a pig.
Then I thought out a plan to make a steamboat of the same
form and with a skeag (Sic) aft under the rounded top, and with
cabins and turrets aft.... (McDougall 1932:32).

The development of McDougall’s concept for the whaleback can be traced through his patents applications (Zoss 2006:213). McDougall’s initial patent application, submitted in 1880, shows a very basic concept, with a nearly cylindrical cross-section (Zoss 2006:214-216; US Patent 241813). As can be seen in Figure 3.2, this early conception is little more than a rudimentary tube with a small rudder. Subsequent patents revised the vessel’s shape to what Zoss neatly describes as a “soft rectangle,” among other refinements (Zoss 2006:218, US Patent 393997). As can be seen in Figure 3.3, the concept has developed considerably, especially in the differentiation of the bow, stern, and midships cross-sections.

(No Model.)

A. McDougall,
Tow Boat.

No. 241,813.

Patented May 24, 1881.

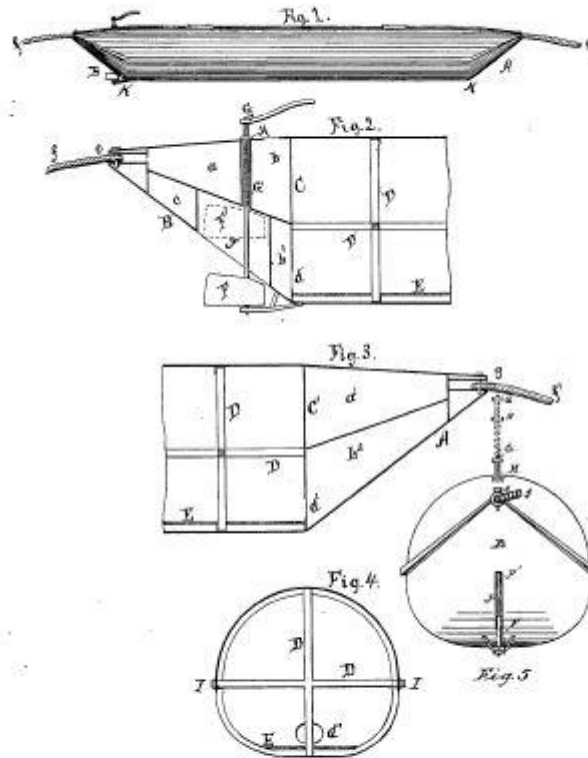

Witnesses.
S. M. Abbott.
H. W. Harding.

Alexander Hallenquell, Inventor
By *Tracy, Dyer & Wilber,*
Attorneys.

© 1881 McDougall, Hallenquell & Co.

FIGURE 3.2. McDougall's initial "Tow Boat" patent (US Patent 241,813, 1881).

(No Model.)

A. McDOUGALL.
TOW BOAT.

3 Sheets—Sheet 2.

No. 393,997.

Patented Dec. 4, 1888.

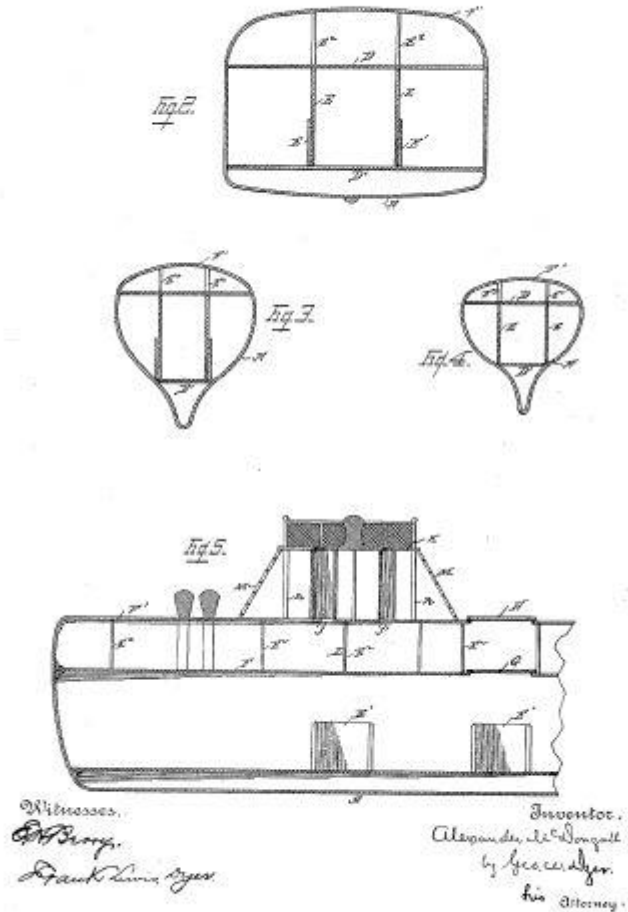

FIGURE 3.3. By 1888, McDougall’s concept of the whaleback hull form had become nearly rectangular in midships cross-section, although the basic concept of a hull which offered minimal resistance to seas remained (US Patent 393,997, 1888).

While McDougall is not recorded as crediting any predecessors, the whaleback has several ancestors, and fits into a general shipbuilding lineage which Guthrie refers to as “cigar ships” (Guthrie 1970:21). While it is impossible to prove that Captain McDougall had any knowledge of these predecessor vessels, it is not much of a stretch to suppose that he did, as they were well reported in the press, and probably would have been discussed in the shipbuilding

community on the Lakes, if for no other reason than their novelty. They are presented here in order to help establish the whalebacks' place in a continuing shipbuilding tradition.

Incidentally, the trend towards streamlining wasn't confined to maritime conveyances, and it is possible that McDougall could have taken inspiration elsewhere, for example from Calthrop's streamlined train, patented in 1865 (US Patent 49227; Figure 3.4). While McDougall and many of his chroniclers tend to present whalebacks as a singular phenomenon, they were in fact part of a more generalized movement. Captain McDougall wasn't the only one to recognize the new possibilities that ready access to steel represented.

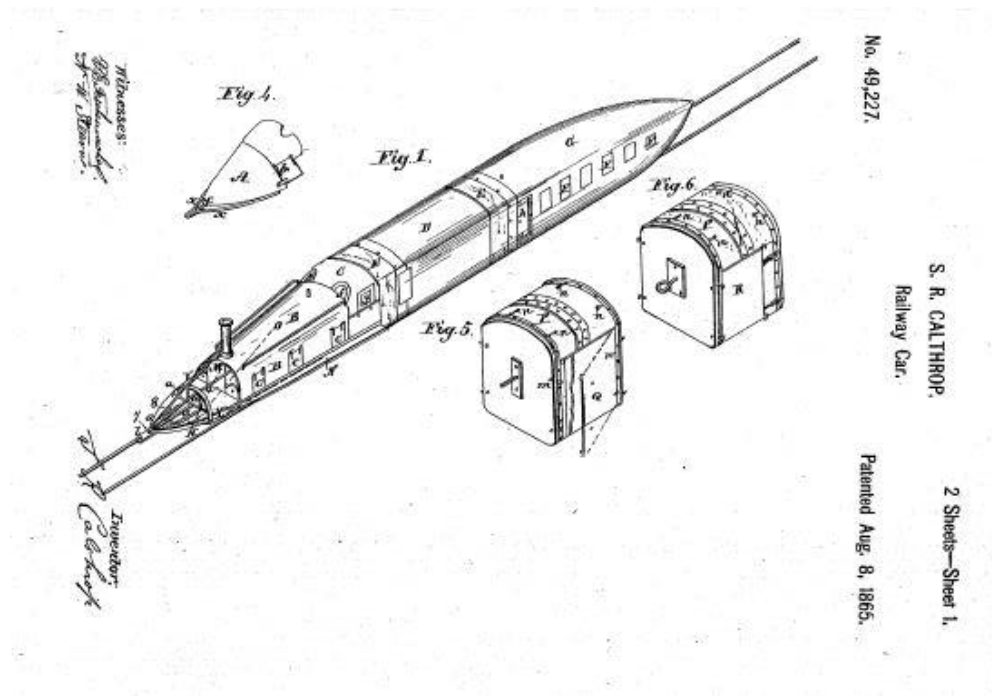

FIGURE 3.4. Samuel Calthrop's patent for a streamlined steam train, patent 1865, shares features with the cigar ships (US Patent 49,227, 1865).

The first of the whalebacks' maritime antecedents were the Winans steamships, named after their inventors Ross Winans and his son Thomas. The first in the series, the only one of the family of four ships built in the United States, was launched in Baltimore in 1858 (Guthrie 1970:218). Its hull was a tapering tube, terminating in two conical points fore and aft, with a circumferential drive propeller mounted amidships. The basic conception of hull form is visible in Figure 3.5. Among the many claimed advantages of the novel craft, Messrs. Winans claimed that:

. . . [T]he form of the vessel, while it makes her stronger than usual, is such as to afford the least possible hold for the wind and waves; so that the danger of injury from heavy seas and storms is small. For these reasons, it is believed that the vessel will be an unusually safe one.

The fact that every portion of the hull or outer shell of the vessel is arched in all directions, and the entire material is in the best possible position and form to resist the various strains that it can be subjected to at sea, gives it an important advantage in point of strength, safety, and buoyancy over any other sea-going vessel (*Harper's Weekly* 1858:676-678).

Notably, whether it was a matter of influence, or parallel thinking, McDougall claimed similar merits for his whalebacks. While the Winans' ships were decades ahead of their time in many respects, they were never a commercial success; the ships' claustrophobic interiors and their weather decks which were reportedly almost uninhabitable from the spray thrown by their propellers were two reasons out of many (Guthrie 1970:22-28).

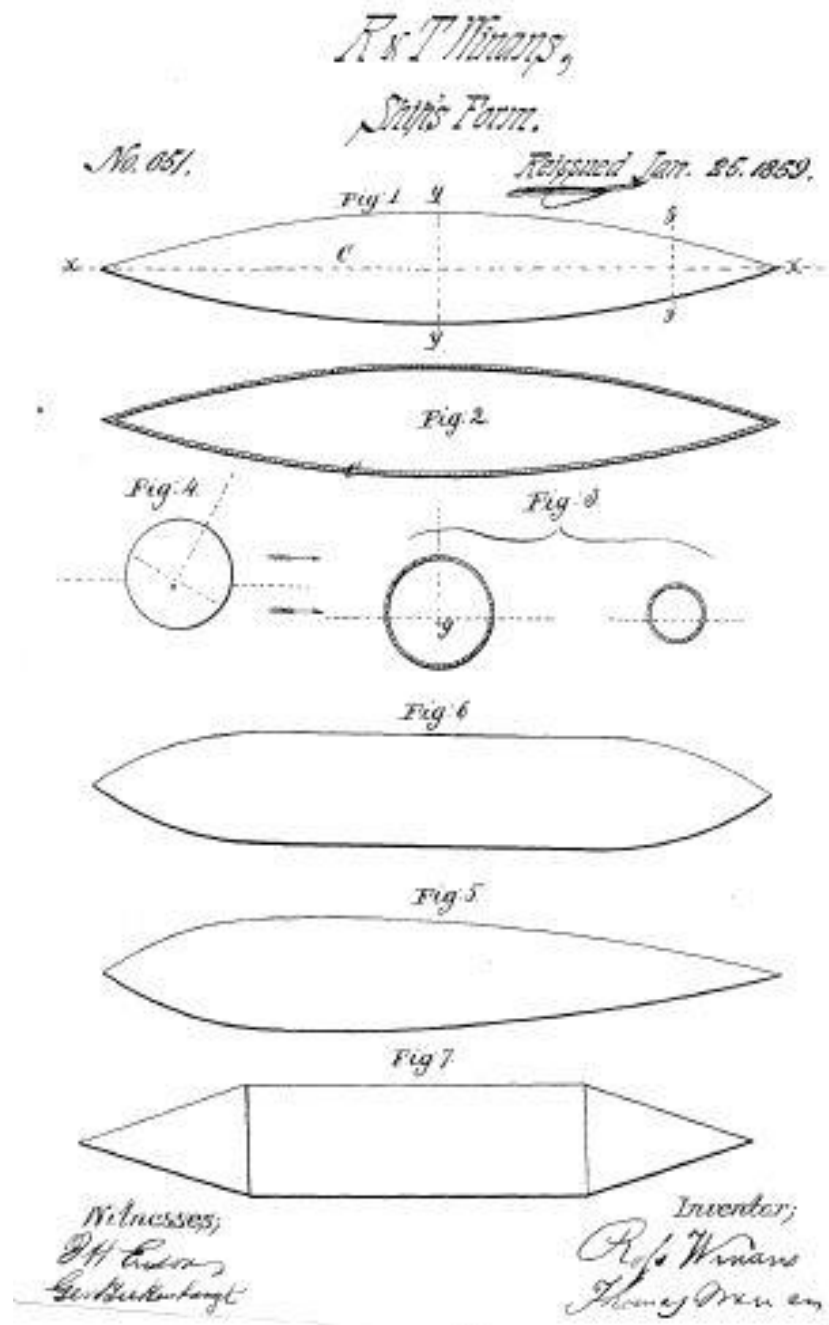

FIGURE 3.5. Winans' Steamship (US Patent 651, 1859).

A second prominent ancestor of McDougall's whalebacks was the barge built in 1877 to transport Cleopatra's Needle from Alexandria to London. The second millennia BCE obelisk was presented to the United Kingdom by the ruler of Egypt in commemoration of Nelson's Nile

campaign (Wilson 1878:v-vii). A tubular pontoon, crimped into a plumb bow and stern at both ends, the barge was constructed around the obelisk it was created to transport (Figure 3.6). The 92 foot vessel was equipped with a small cabin on deck and a suit of steadying sails, but was essentially a purpose-built package for a single delivery. It had the additional advantage that, stripped of its deck fittings and cabin, it could be rolled to its destination on land (*Scientific American* 1877:1089-1091). Wright specifically speculates about a connection between the Cleopatra's Needle barge and McDougall's whalebacks: "he may have conceived the idea of a cylindrical hull on a visit to England in 1873, where he had an opportunity to examine such a hull designed to carry the Egyptian obelisk from Alexandria to London" (Wright 1969:43).

A third forebear of McDougall's whalebacks was H.M.S. *Polyphemus* (Figure 3.7), a unique torpedo and armored ram vessel commissioned by the British Navy and launched in 1880. With a hull shape tending towards oval, she apparently had a tendency to be crank in a seaway. Her low profile would have made her a potentially difficult target, and armed rams were somewhat in vogue at the time (Guthrie 1970:32-36).

These rhapsodies in steel were not confined to cigar ships. Russian Emperor Alexander II commissioned the turtle-shaped *Livadia*, launched 1890, 153 feet abeam on a 235 foot length. Although she was nearly immune to rolling, her flat bottom pounded alarmingly in a heavy sea state, eventually causing her hull to crack, and discouraging further experiments in that direction (Leggett 2015:44-49).

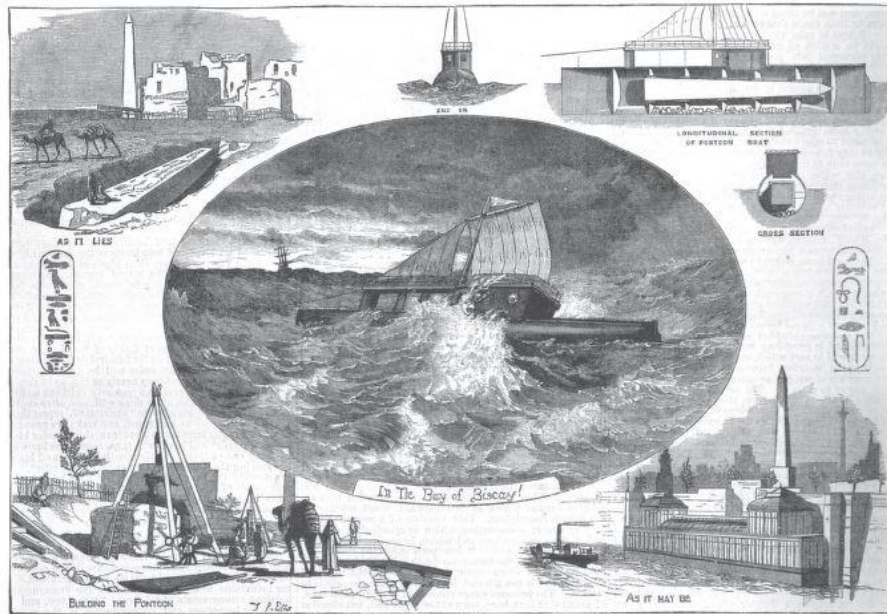

REMOVAL OF CLEOPATRA'S NEEDLE FROM EGYPT TO ENGLAND.

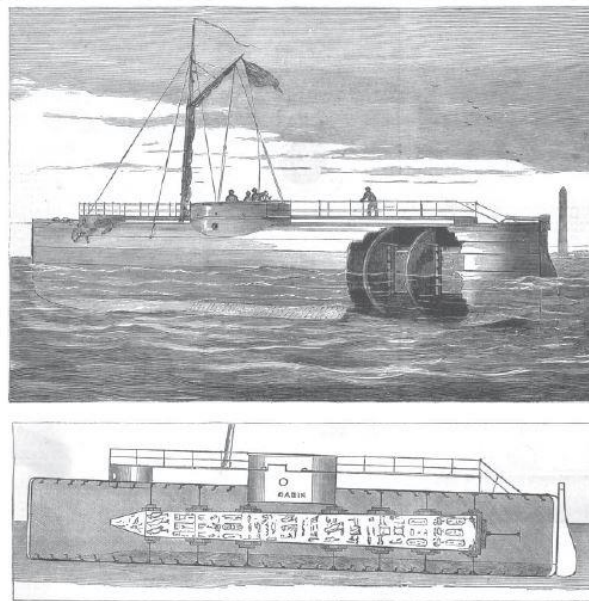

REMOVAL OF CLEOPATRA'S NEEDLE FROM EGYPT TO ENGLAND.

FIGURE 3.6. The Cleopatra's Needle Barge. Although a singular vessel, the family resemblance to whalebacks is clear (*Scientific American* 1877:1090-1091).

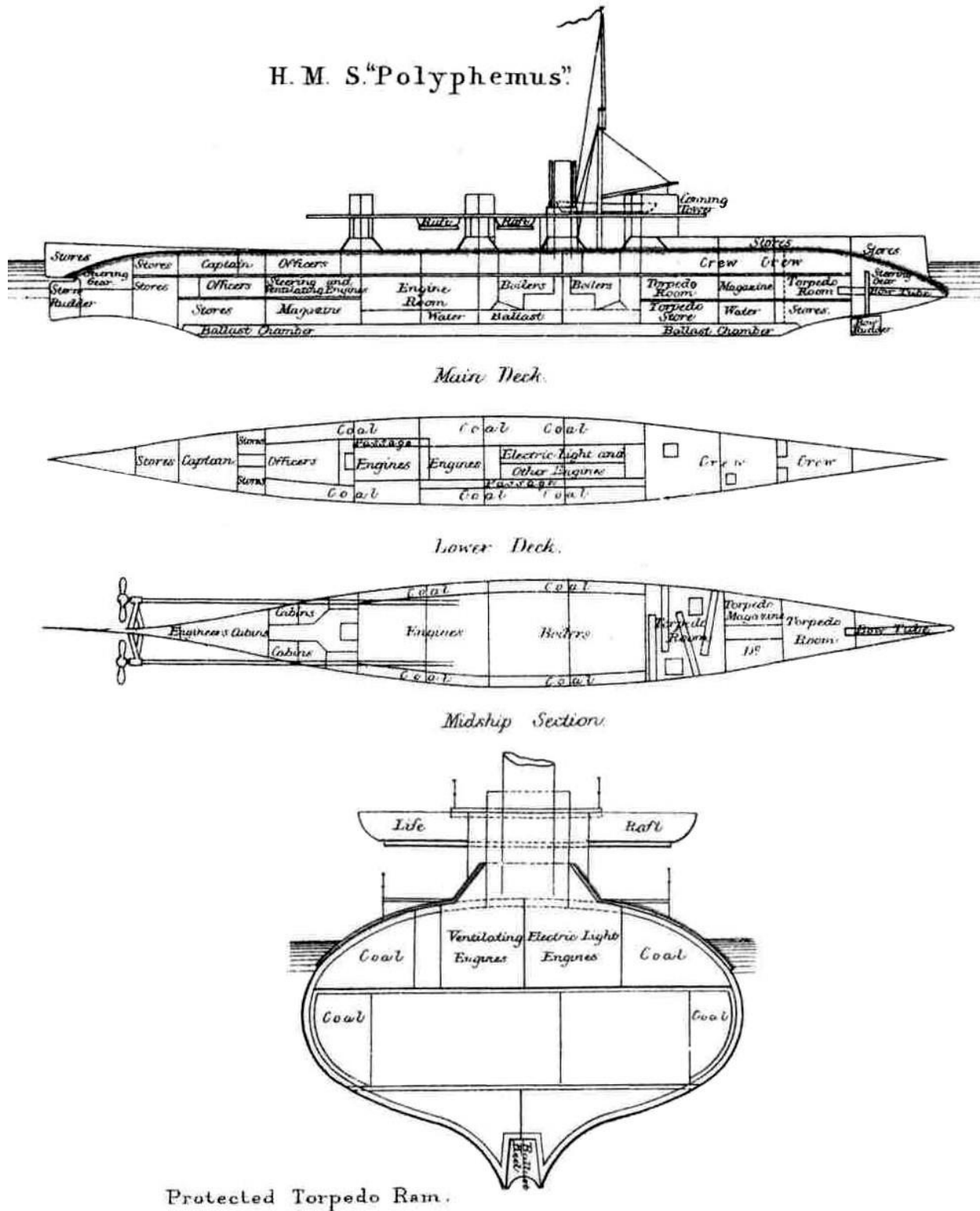

FIGURE 3.7. HMS Polyphemus (Brassey 1888:Plate 38).

While the members of the cigar ship family were not necessarily related in the sense of one design leading to the next, they were at least causally linked. Iron and steel, the new media of shipbuilding, offered possibilities that wood did not. Iron and steel were lighter, stronger and more versatile than wood. A wooden ship was effectively limited, both in size and form, by the structural properties of timber and by the size, shape, and availability that this timber occurred in nature. Since steel plates and beams were made, not grown, the nineteenth century shipwright was essentially freed from millennia of traditional design constraints (Guthrie 1970:v-vi;21;43-44).

By the nineteenth century, humanity found that the castles and ramparts which had once been his greatest security in strife no longer served. As von Clausewitz wrote in the early 1800s, “the times are past in which the mere enclosure of a place with walls . . . could keep it perfectly dry when an inundation of war was sweeping over the whole country” (von Clausewitz 1943:358). The ever increasing destructive power of artillery and various other implements of mayhem in a mechanized age made high fortresses unsafe. Those upon the field of battle were forced to engrave trenches upon the face of the earth, and burrow deep into bunkers. War had changed and the only safety from the seas of fire and metal was to be found underground (Keegan 1976:231-240).

McDougall and the other cigar ship builders chose to burrow, when the accepted practice in shipbuilding had, for thousands of years, been to build castles upon the ocean, with high prows and sterns as bulwarks. They abandoned the prevailing wisdom of generations, as if humanity’s millennia long contest with the sea had changed. Obviously, the sea had not changed. The ground rules of the struggle had changed, however, and McDougall and the others, consciously or unconsciously must have recognized this. Only in the nineteenth century

did the engine arise to challenge and eventually supplant sail as the primary motive power on ships, and the repercussions of this critical technological shift have been manifold and slow to play out (Baker, Tryckare 1965:9-16). The crux of the matter is this: that while all vessels are suspended between two sometimes hostile elements and exist at the unfriendly interface between the two, they do not do so equally. The sailing ship favors one parent, the sky. All ships depend on water for buoyancy and traction. The sailing ship depends on wind for impulsion. To the steamer, the wind is seldom better than an inconvenience, and sometimes a hindrance. When air and water conspire together, they can produce some of the things that are most baneful to mariners: fog, snow, rain, spray that turns to ice, and of course waves. The vast majority of waves are formed by friction between water and moving air, that is, the wind drags the sea along with it (Van Dorn 1955: 187-190,258).

Because a sailing ship derives its power from the wind, and because the wind is stronger and less turbulent higher aloft (Harland 1984:58), it behooves the shipwright to build a sailing ship's rig as high as strength of material and the vessel's stability render sensible. Because the sails and the men who work them must be above deck, even when the vessel is heeling, the deck must necessarily be to some degree raised and protected, usually in proportion to the conditions of the waters the vessel is built to ply (Harland 1984:45). The builder of sailing ships builds a castle.

An engine, conversely, is best kept low, as it is usually one of the densest, heaviest pieces of equipment on a ship. Vessel stability makes it strongly preferable that a ship's power plants be kept as deep in the vessel as possible (Benford 199:26-28). The main impetus for building a castle vanishes, although secondary reasons might remain, and the shipwright is free to experiment with burrowing, with hiding the greater part of the vessel from wind and waves.

Another factor is as follows. Because wind and wave are usually aligned, and because a sailing vessel cannot move directly upwind, a sailing vessel almost never has to meet waves head on for an extended period of time (Harland 1984:61-65). A motor vessel, conversely, can steam dead upwind, crashing directly into the seas. Hull designs have been forced to evolve in response, and the cigar ship is one approach. In the case of H.M.S. *Polyphemus*, the metaphor of entrenchment is especially apt, as her rounded hull allowed her to keep most of her essential systems below her waterline (Figure 3.7), but in all cases, the leap forward in thinking about a vessel's essential relationship with the sea is the same. It did not necessarily follow that a ship executed in steel would look anything like a wooden one. McDougall and the other cigar ship builders struck out boldly in a new direction.

CHAPTER 4: THE FLEET

Between 1888 and 1897, a total of 44 whalebacks were launched, all but one of them by McDougall's American Steel Barge Company. The 44th, the British *Sagamore*, was an unlicensed copy of McDougall's design. All but one of McDougall's whalebacks, the passenger vessel *Christopher Columbus*, were built for the bulk trade. McDougall's fleet of bulk freighters and barges totaled a staggering 61,020 gross tons as built, and if laid end to end would have stretched out for over two miles (Table 1.1; Table 1.2). How did McDougall go from his wife apocryphally exclaiming, "There goes our last dollar!" at the launch of Barge *101* to admiralty of this considerable fleet? The answer is essentially twofold: conditions and capital. We have already seen in Chapter 2 how the Great Lakes at the close of the nineteenth century presented ideal conditions for McDougall, especially in terms of the rapidly growing demand for tonnage and the destabilizing technological shift from wood to steel shipbuilding. The other element, financial backing soon fell into place:

Then, in 1889 I made a model for *No. 102*, which was to be nearly twice as large as the first barge. I showed this model to many ship owners who wanted iron ships. The rates were high at that time, but all I could get was sympathy. So I took my model to Colgate Hoyt, New York, an associate of John D. Rockefeller, who had much lake ore to move, and I told him of my patents and plans; also of my past experience, which he carefully investigated, with the result that I agreed to sell to a company all my patents for \$25,000 and take it in stock in the company . . . called the American Steel Barge Company (McDougall 1932:32-33).

It is noteworthy that McDougall transferred his patents to the newly formed American Steel Barge Company in 1889, in exchange for stock. In effect, this meant that when he eventually lost control of the company, he would lose control of his designs as well. However, for the time being, it gave him the capital and support to pursue his design on a large scale (McDougall 1932:33,48-49). Between 1888 and 1893, McDougall produced 13 of his 17 propellers and all

but two of his barges (Table 1.1; Table 1.2). The high tide of the Great Lakes fleet, at least in number of hulls, was reached in 1893, at 3,018 vessels (Thompson 2000:28). By 1929, the number had fallen to 839 (Thompson 2000:185). McDougall was riding this tide, the narrow window at which demand for tonnage was increasing rapidly, but before it began to be reconsolidated into larger vessels.

Daley, with sound evidence, credits McDougall's staff, especially his chief draftsman, Robert Clark, with doing most of the heavy lifting in terms of advancing McDougall's general concept to a workable real-world vessel (Daley 2000:25-32). Regardless, history has remembered whalebacks as primarily McDougall's.

Boom Times

McDougall's contact with Rockefeller was through two sets of intermediaries. He received financing through an Eastern syndicate, prominently including Colgate Hoyt (McDougall 1932:32-33). He lost it at the hands of Frederick T. Gates (McDougal 1932:47-49).

Frederick T. Gates was essentially a professional cynic. As he was, by profession, a Baptist minister, this is not without a measure of irony. He was employed by Rockefeller as a financial guard-dog. His initial purview was Rockefeller's extensive charitable giving. Rockefeller was beset with a continuous flood of requests for gifts, most of which lacked merit. He retained Gates to sort the wheat from the chaff, and to impose order and regularity over his charitable activities. Gates' responsibilities were eventually extended to include Rockefeller's investments also. Upon investigation, many of these investments turned out to be of rather dubious value (Rockefeller 1933:115-120; Daley 2000:69-72; Chernow 1998:367-370).

John D. Rockefeller did not become fabulously wealthy by accident, but the acquisition of wealth was not his primary motivator. He seems to have been driven, in his consolidation of the petroleum industry under the Standard Oil banner, by an almost religious need to maximize efficiency and the justifiable belief that he was the one to do it, what Chernow describes as an “overmastering need for order” (Chernow 1998:80). Money was, perhaps, his way of keeping score, but Rockefeller, over his career made more than he knew what to do with.

Going into the iron-ore fields was one of those experiences in which one finds oneself rather against the will, for it was not a deliberate plan of mine to extend my cares and responsibilities. My connection with the iron ores came about through some unfortunate investments in the Northwest country (Rockefeller 1933:115).

Gates’ investigation of the West Superior Iron and Steel Company and the associated West Superior Land Company, located in Wisconsin proved to be something of a turning point. The following rather long passage from Gates’ autobiography is worth repeating, as it sums up the situation rather neatly:

[Rockefeller] had made . . . very numerous and very large investments, some fifteen or twenty in all, East and West, and even some outside the United States. The aggregate of these investments was several millions. The fact is Mr. Rockefeller had been completely absorbed in the interesting development of the Standard Oil Trust. That had been highly speculative. It had proved an Aladdin’s lamp. He had found no other time to investigate other things. When a group of friends . . . composed of old friends, church friends, good Baptist friends, came to him with tales of rapid and prodigious fortune in highly speculative new enterprises into which they were putting their own money freely, and offered him a share on the “ground floor” he was always ready to go in with them in those days without much inquiry. . . . This West Superior investment made at the behest of these friends, and now shown to be reckless was his first great shock. . . . He had found his friends completely deceived in this investment . . . May

they not have been equally deceived in many of the other investments he had made with them (Gates 1977:169)?

In the aftermath of the panic of 1893, and in the midst of a personal dispute between Hoyt and Gates, McDougall effectively lost control of, and his stake in, the American Steel Barge Company. He might have fared better had he abandoned his backing of Hoyt, but he was apparently not one to go back on personal loyalty (McDougall 1932:48). A few more whalebacks trickled out of the yard in Superior over the next three years, but the era of whaleback construction was effectively over (Wright 1969:49-50). Relying on primary sources, Daley squarely lays responsibility for the whalebacks' demise at McDougall's own feet, citing a failure to innovate and McDougall's loss of interest in his design when he lost control of the American Steel Barge Company (Daley 2000:72-75). McDougall's success was always predicated on a certain amount of bluster and force of personality, and in Gates he apparently met his match.

McDougall's loss of his company to the direct control of the Rockefeller interests was just a small part of an overall pattern of consolidation, both on the Great Lakes, and nationwide, in the aftermath of the panic of 1893 (Morris 2005:251-155). In 1899, the American Steel Barge Company was one of seven Great Lakes Shipyards consolidated into the newly formed American Shipbuilding Company, which by 1900 would control virtually every shipyard on the lakes. With the twentieth century dawning, Great Lakes shipbuilding was in the hands of a monopoly. Bulk freighter design would be standardized; deviations like whalebacks would no longer be seen (Wright 1969:138-143).

In a way, the middle of the story outlasts the end. While the history of the American Steel Barge Company was almost incandescently brief, the vessels themselves persisted. Whaleback propellers enjoyed an average lifespan of 38 years, barges 18 years (Table 1.1; Table

1.2; Figure 5.2; Figure 5.6). This meant that they were a regular feature on the Great Lakes into the 1930s, with the longest serving, *Frank Rockefeller*, active until 1972. While all but *Christopher Columbus* were built as bulk carriers, many eventually transitioned into other careers. *Rockefeller* spent time as a sand-dredge and a car carrier before being converted to a petroleum carrier for the last three decades of her life (Lydecker 1973:28-29). Transition from trade to trade was common for the longer-lived whalebacks. Essentially, the economic question of whether a vessel type is worth constructing more of is completely different than the question of whether an already built vessel was too good to scrap (Wilterding 1969:22,28,39,54,57,60).

A Fleet of Orphans

Once released into the wild, McDougall's vessels went about their quotidian lives, independent of the fortunes of McDougall or his company. Many met their end by misadventure, although not in numbers out of keeping with their contemporaries. None were scrapped before serving three decades. They remained a normal, if somewhat out of the ordinary, part of trade on the Lakes for many years. In the final chapter, disposition analysis will show that whalebacks were not statistically shorter lived than comparable contemporary vessels (Figures 5.1-5.8).

McDougall, for his part, seems to have simply moved on. He enters the record mostly in connection with whalebacks, although his own autobiography makes clear he remained active in his later days (McDougall 1932:50-67). However if there is little written about his sunset years, there is also little indication of acrimony on his part. Perhaps he was too much of a practical man to dwell overly on the past, and he remained able to sustain a comfortable lifestyle (Clark 1998:5). He passed away in 1923 at the age of 78, and is well remembered in Duluth as one of its most prominent citizens (McDougall 1932:68).

Although the period of whaleback production on the Great Lakes was relatively brief, the design can be seen to have survived in various forms. On the lakes, whalebacks inspired two variant types, “turtlebacks,” which sported rounded foredecks, and “monitors,” or “semi-whalebacks,” which had conventional bows, but many of the other features of McDougall’s vessels. Both of these types were only built during the early 1890s (Wright 1969:7). A lawsuit by McDougall against the builder of these monitors, the Cleveland Shipbuilding Company, did nothing to encourage their development (Daley 2000:39).

The Turret Ship was a clear whaleback descendant. Between 1891 and 1911, 182 of these vessels were produced, mostly by the shipbuilding firm of William Doxford and Sons Limited, of Sunderland, England. The Turret design, which refined the basic whaleback concept by adding a raised centerline trunk, had the advantage of being self-trimming. As can be seen in Figure 4.1, this centerline trunk was essentially an evolution of a whaleback’s turrets into a continuous structure. Although the primary goal of the design was seaworthiness, it had the added benefit of paying relatively low Suez Canal tolls, which were calculated based on deck area (US Patent #896,900; Gray and Lingwood 1975:2-5).

C. D. DOXFORD.
TURRET VESSEL.

APPLICATION FILED JUNE 24, 1907.

2 SHEETS—SHEET 1.

Fig. 1.

FIGURE 4.1. Midships cross-section, Doxford Turret Ship. The rounded deck edges of the whaleback type are augmented with a raised centerline trunk (U.S. Patent #896,900, 1907).

A modern vessel which is a clear off-shoot of the cigar-ship family is the dracone. These flexible barges are designed for transporting fluids. Interestingly enough, dracones represent conceptual leap in shipbuilding material one remove further than the transition from wood to steel which made whaleback possible. As stated in the patent claim for dracones, “barges are at present made of metal wood, or other material which is still and rigid, and usually have large

openings above the water line. This is unnecessary if the barge is only to contain liquids” (US Patent # 2997973). Figure 4.2 illustrates how, conceptually at least, a dracone is the descendant of the Winans’ steamships, the whalebacks, and other cigar ships, tubular and eschewing freeboard.

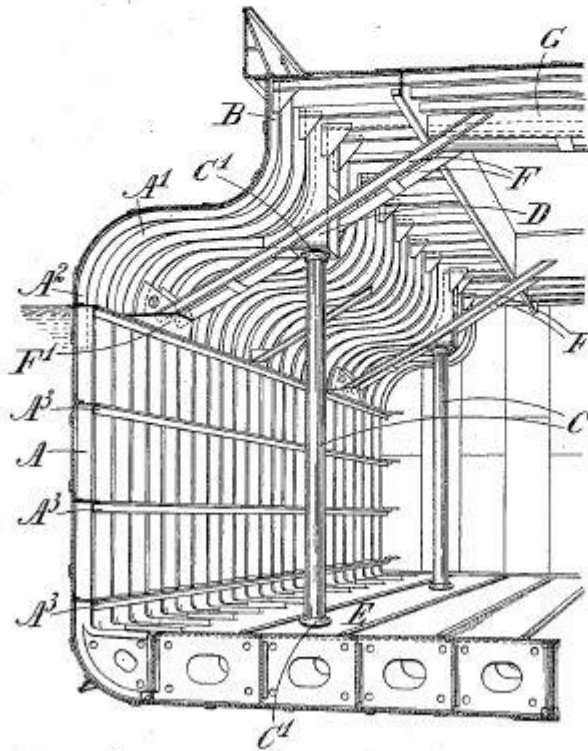
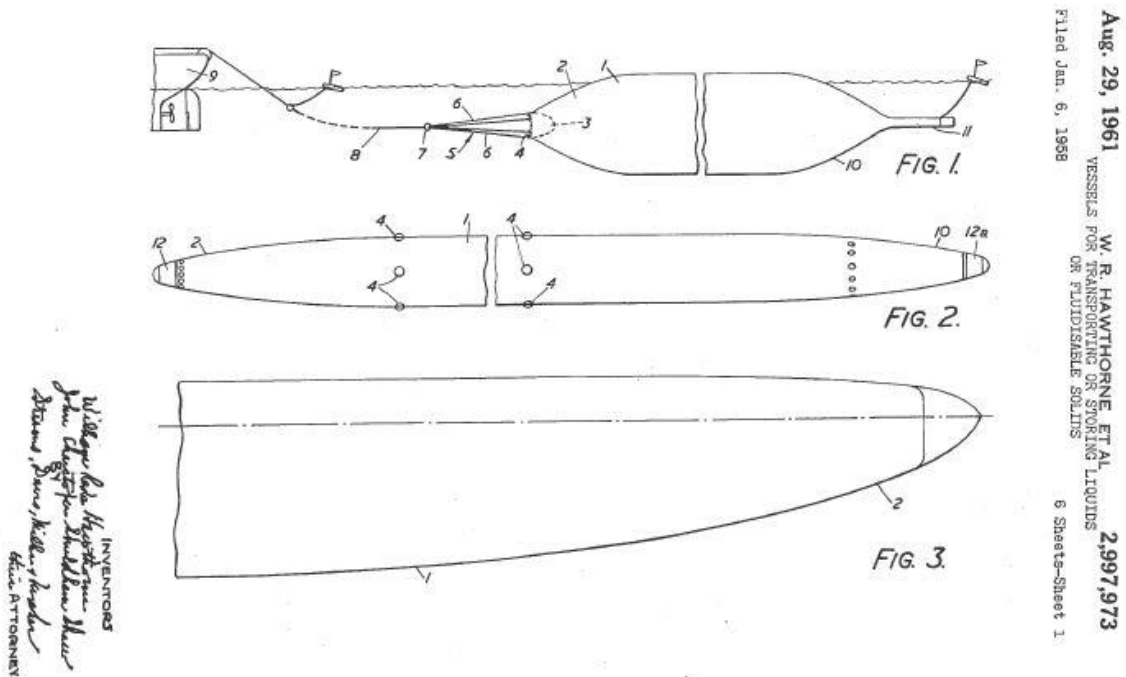

FIGURE 4.2. Profile of a Dracone type barge (US Patent #2,997,973, 1961).

CHAPTER 5: RECKONING

A recurring theme in the literature relating to whalebacks is the question as to why they failed (Daley 2000:7-10). It is possible though, to posit, that the vessels did not in fact fail at all. Certainly, they stopped being built, representing a failure of McDougall's American Steel barge Company. The rise and fall of ASBC, though, as the company which McDougall built, as distinct from the Rockefeller run successor which was not much later subsumed by the American Shipbuilding Company, can be explained adequately by the interactions of market forces, infrastructure developments, and personalities outlined above. If we separate the company which built whalebacks from the basic premise, and further, from the ships themselves, as constructed and operated, it can be argued that the design acquitted itself more than adequately.

Certainly the whaleback failed to displace the conventional Great Lakes freighter as the dominant type, although in the previous chapter we have seen the basic design ideas which typified whalebacks have continued in other vessel types. As an idea, it must be conceded that the whaleback concept, if never wholly embraced, has also never been wholly discredited either.

In order to compare whaleback freighters with their contemporaries, the data set presented in Appendix A was compiled. The data set is composed of 384 ships and 26 whaleback barges, for a grand total of 410 vessels. All of these vessels were built between 1867 and 1900, the transitional period between wood and ferrous shipbuilding on the Great Lakes (Hoyt 2008:1-2). *R. J. Hackett*, 1867, is generally recognized as the first modern bulk carrier in the Lakes trade (Figure 1.3; Devendorf 1995:7,53; Thompson 1991:22-23). Its construction is a natural starting point for the data set. The terminal year, 1900, was adopted as a round number, yielding a period of 33 years. This period includes the nine year interval between 1888 and 1897 during which whalebacks were built, and two major improvements in Sault locks infrastructure

(Chapter 2). Of the 384 ships in the data set, 230 were wood. Of this subset of 230 wooden ships, seven were of composite construction, wood with substantial structural use of steel or iron. The remaining 154 ships are of ferrous construction, four being constructed in iron, with the remaining 150 being steel. Fifteen of these steel ships were whalebacks.

This analysis is based on two assumptions and one unfortunate reality. The first assumption is that ships somehow deserve the fates they get, and that if ship type 'A' in the aggregate outlives ship type 'B,' that type 'A' is demonstrably better. Of course bad things happen to good people, and likewise, bad things may happen to good ships. The second assumption is that any two ships and their careers are comparable. In reality there are a thousand variables over the life of a ship: miles run, route, length of season, owners, power plant, weather, captain and crew, and on and on. Proverbially, for want of a nail, the ship was lost, and we are in no position to count nails. The unfortunate reality is that we have a finite number of Great Lakes freighters and a very finite number of whalebacks to compare. In a perfect world, we would be able to run a thousand whalebacks and a thousand conventional freighters in a continuous circuit from Buffalo to Duluth, until some clear favorite emerged. In practice, we have no such luxury.

As a group, the 384 ships had an average lifespan of 33 years. Two hundred and thirty ships, or 61%, burned, sank, wrecked, or sank as a result of a collision. One hundred and fifty, or 39%, were scrapped. Four, 1%, were sunk by enemy action in wartime. Figure 5.1 shows causes of loss for all vessels in the data set.

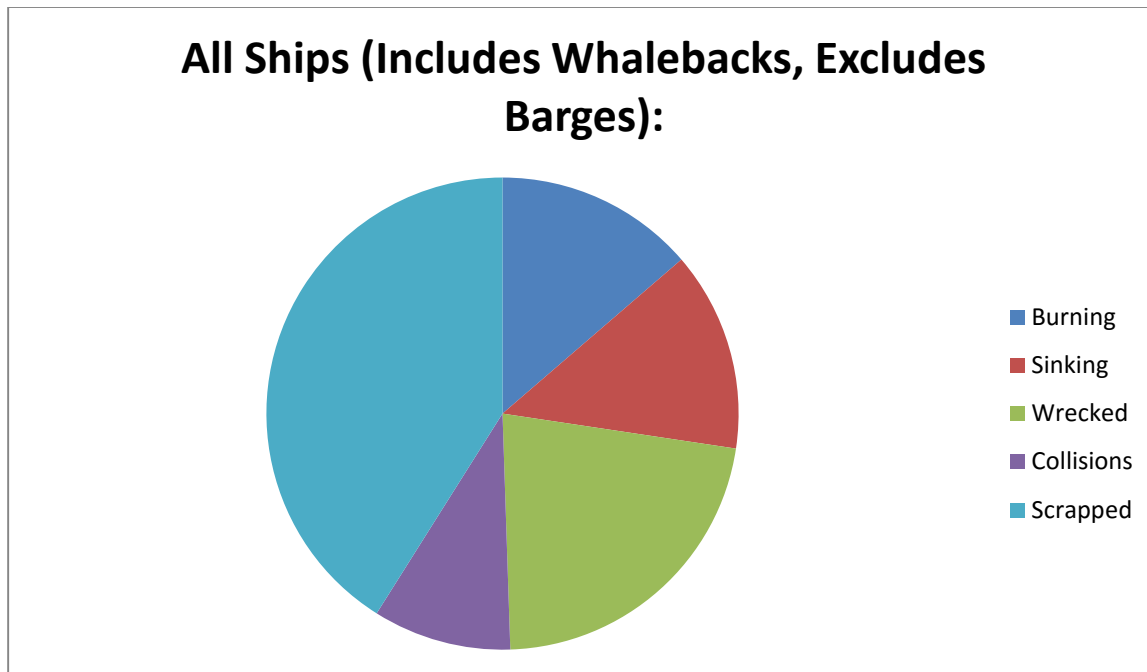

FIGURE 5.1. Cause of loss of all bulk freighters, including ferrous and wooden, but excluding barges. Average built tonnage: 2111. Average final tonnage: 2159. Average lifespan: 33 years. Burn: $50/384 = 13\%$. Sank: $62/384 = 16\%$. Wreck: $82/384 = 21\%$. Collision: $36/384 = 9\%$. Scrapped $150/384 = 39\%$. Other: $4/384 = 1\%$. Natural causes: $150/380 = 39\%$. Unnatural causes: $230/380 = 61\%$.

There is a marked contrast between wood and ferrous ships, as might be expected. Wood ships had an average lifespan of 25 years (Figure 5.2), as compared to an average lifespan of 45 years for ferrous vessels. No ferrous ships burned, but fifty wooden ships did. It will surprise no one that the wooden ships proved more inflammable than their wooden counterparts, but the fact that a full 22%, nearly a quarter, of wooden ships ultimately burned is a rather stark figure. Interestingly enough, factoring out wooden vessels whose final disposition was a result of burning does nothing to improve the average longevity of the wooden fleet. Wooden ships whose final disposition was a result of any cause other than burning still only had an average lifespan of 25 years (Figure 5.3). This seems to reflect that, proclivity to burst into flames aside, wooden vessels were simply less robust than their ferrous counterparts. With the vast majority,

77%, of wooden ships meeting an untimely end by burning, sinking, wrecking, or collision, it seems that obsolescence was not a major factor, even though the period examined marks the transition between steel and ferrous vessels. We might posit that wooden ships engaged in the strenuous bulk trade simply wore out faster than their steel counterparts, and that by their second decade they were living on borrowed time, but a thorough examination of the subject is beyond the scope of the present study.

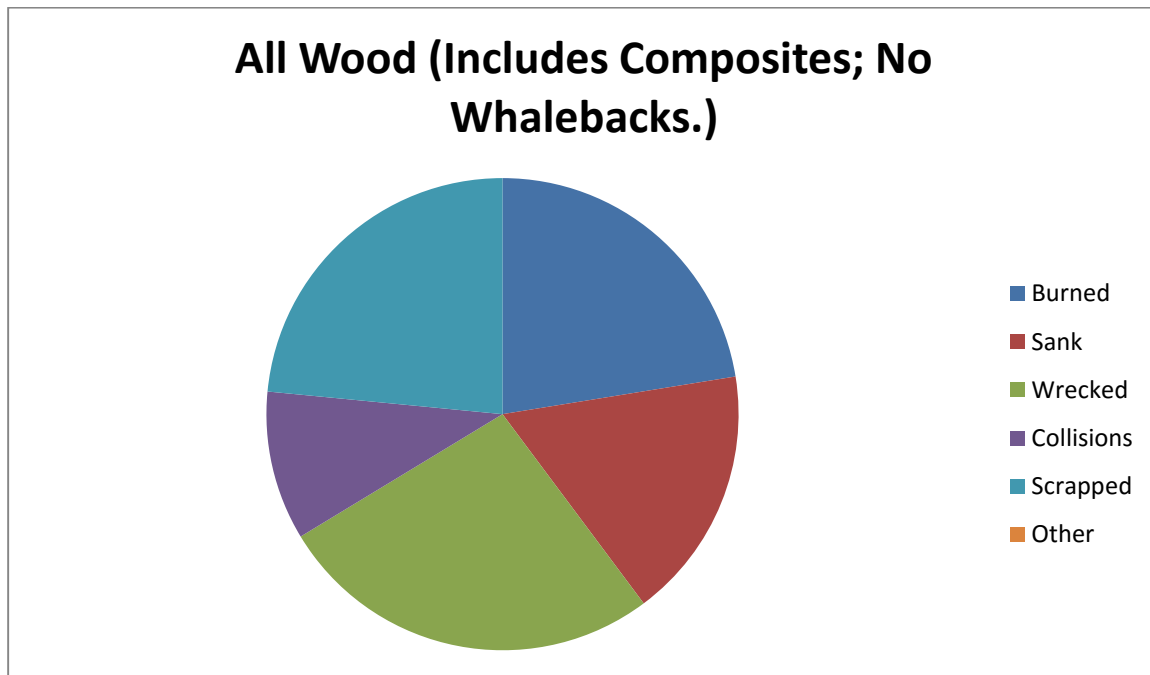

FIGURE 5.2. Cause of loss of all wood freighters (no whalebacks) (includes composites.) : Average built tonnage : 1495. Average final tonnage: 1532. Average lifespan: 25 years. Burn: 50/230 = 22%. Sank: 43/230 = 17%. Wreck: 60/230 = 26%. Collision: 23/230 = 10%. Scrapped: 54/230 = 23%. Other: 0/230 = 0%. Natural causes: 54/230 = 23%. Unnatural causes: 176/230 = 77%.



FIGURE 5.3. Cause of loss of wood vessels, excluding loss by burning (includes composites): Total years: 25. Sank: $43/180 = 24\%$. Wreck: $61/180 = 34\%$. Collision: $23/180 = 13\%$. Scrapped: $53/180 = 30\%$.

Figure 5.4 shows cause of loss for all whaleback propellers. Whaleback ships fare somewhat better than wooden ships, but somewhat worse than other ferrous ships in terms of longevity, at an average lifespan of 38 years; all other ferrous ships in the data set have an average longevity of 45 years (Figure 5.6). Interestingly enough, within the field of ferrous bulk carriers, tonnage seems to have been a major predictor of longevity, as compared in Figures 5.4 and 5.5. When we control for tonnage, whaleback ships fare almost exactly the same as other ferrous ships. The fifteen whaleback bulk freighters built on the Great Lakes ranged between 1253 and 3686 gross tons. Excluding ships of less than 1253 tons or greater than 3686 tons reduces the sample of ferrous ships to 85, by excluding two ships of less than 1253 tons and fifty ships of greater than 3686 tons. Although the sample sizes involved are no doubt too small to be definitive, the 15 whaleback ships performed uncannily like the 85 ferrous vessels of comparable tonnage. Twenty per cent of the whalebacks sank, as compared with 19% of the comparable

tonnage ferrous vessels. Twenty per cent of each category wrecked. Seven per cent of each category sank as a result of collision. Fifty three per cent of the whalebacks survived to be scrapped, compared with 49% of ferrous vessels of comparable tonnage. Five percent of the comparable tonnage ferrous vessels sank as a result of enemy action in wartime, with no comparable losses from the whaleback fleet. The whaleback ships had an average lifespan of 38 years, compared with 37 years for the ferrous vessels of similar tonnage.

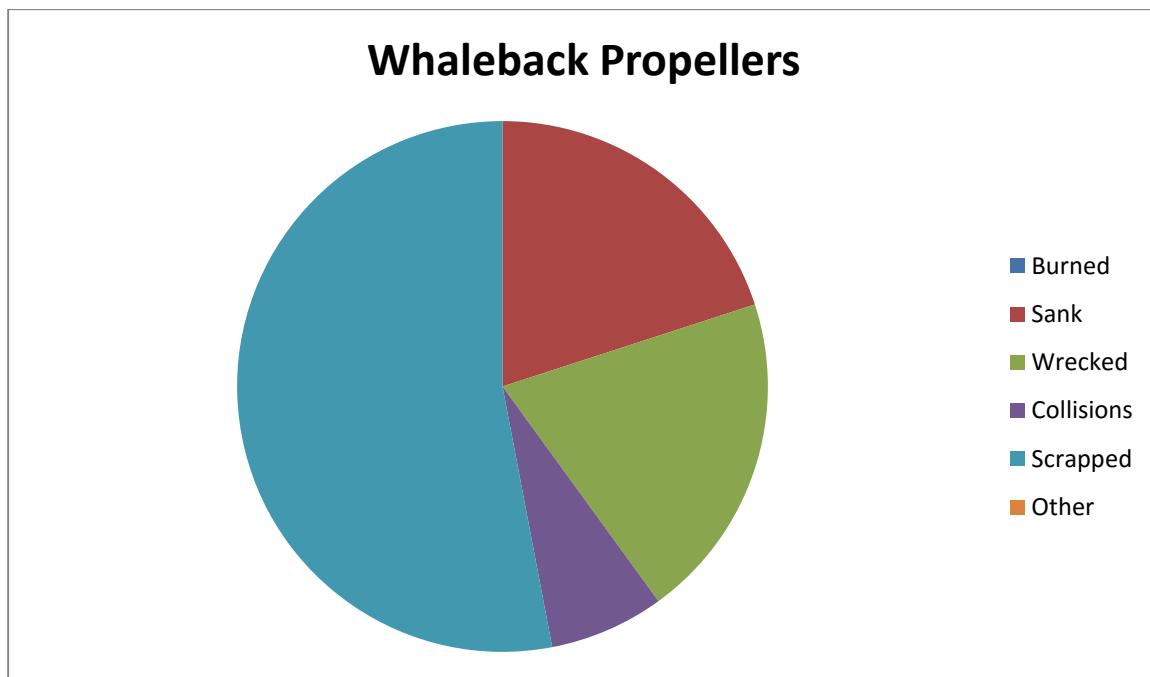

FIGURE 5.4. Cause of loss of whaleback propellers: Average tons built: 2006. Average final tonnage: 2097. Average Lifespan: 38 years. Burn 0/15 = 0%. Sank: 3/15= 20%. Wreck: 3/15 = 20%. Collision: 1/15 = 7%. Scrapped: 8/15 = 53%. Other 0/15 = 0%. Natural: 8/15 = 53%. Unnatural causes: 47%.

Ferrous, Tonnage Comparable to Whalebacks (1253 -3686 Built Tonnage)

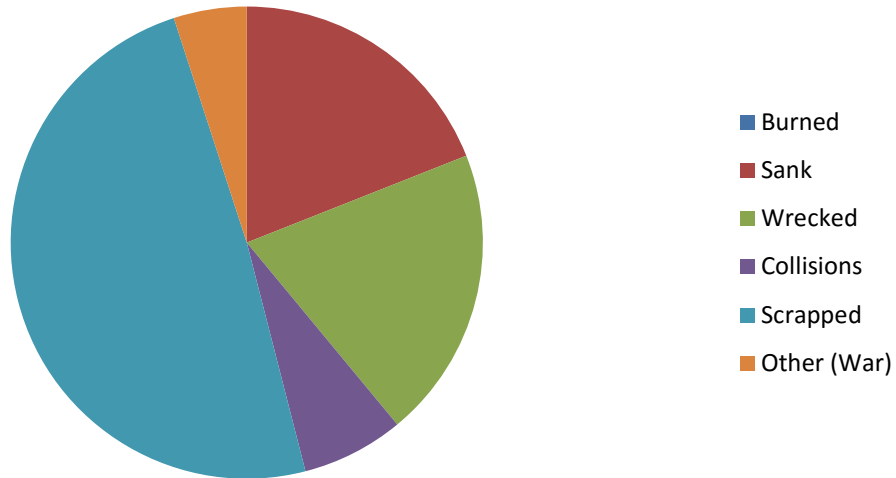

FIGURE 5.5. Cause of loss of ferrous vessels, tonnage comparable to whalebacks (1253 -3686 built tonnage): This excludes only two vessels of tonnage less than whalebacks (i.e. less than 1253.) This excludes fifty vessels of tonnage greater than 3686. Average lifespan: 37 years. Burn: $0/85 = 0\%$. Sank: $16/85 = 19\%$. Wrecked: $17/85 = 20\%$. Collision: $6/85 = 7\%$. Scrapped: $42/85 = 49\%$. Other (War): $4/85 = 5\%$. Natural causes: $42/81 = 52\%$. Unnatural causes: $39/81 = 48\%$.

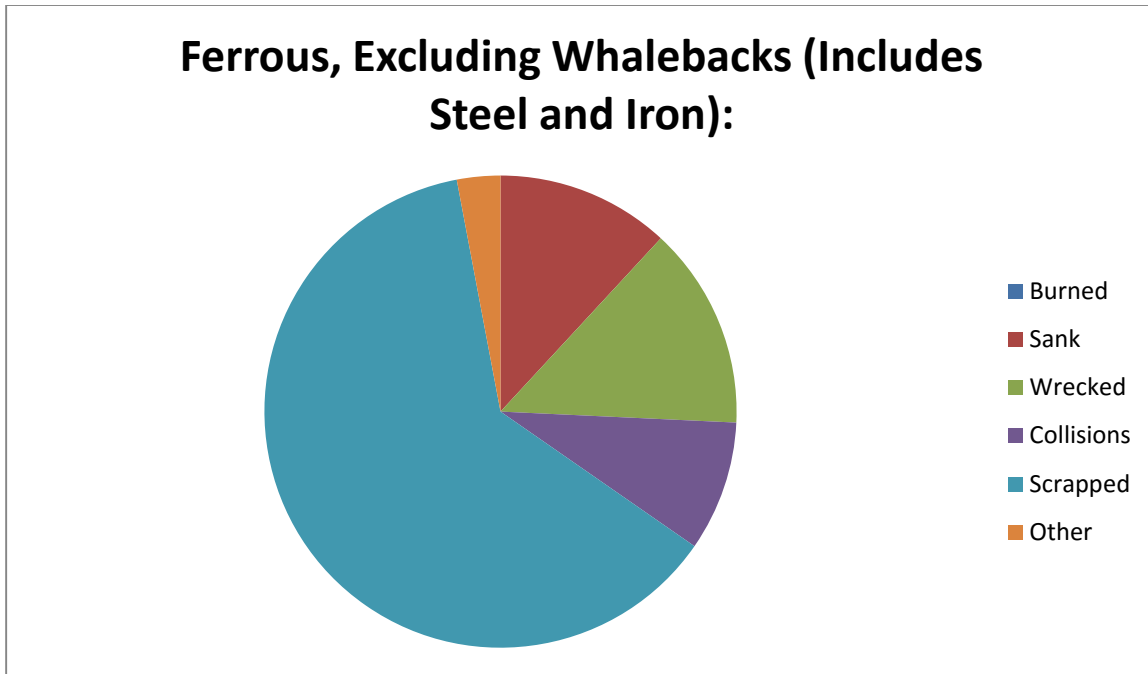

FIGURE 5.6. Cause of loss of all ferrous freighters, excluding whalebacks (includes steel and iron): Average built tonnage: 3142. Average final tonnage: 3204. Average lifespan: 45 years. Burn: 0/139 = 0%. Sank: 16/139 = 12%. Wreck: 19/139: 14%. Collision: 12/139 = 9%. Scrapped: 88/139 = 63%. Other: 4/139 = 3%. Natural causes: 88/135 = 65%. Unnatural causes: 47/135 = 35%.

When we examine only ferrous vessels over 4000 tons, an admittedly arbitrary round number adopted for convenience, it becomes apparent that tonnage was a strong predictor of longevity (Figure 5.7). This subset includes 44 vessels, all built between 1896 and 1900, and correlates closely with the Sault lock improvements of 1895/1896. This increased longevity is probably because after a certain tipping point, ships had arrived at a size relative to the capacity of locks, canals and rivers in the Great Lakes which remained competitive for a longer time. We might also look to overall improvements in the safety of navigation, including the adoption of wireless radios, improvements to lighthouses and other aids to navigation, and the like. At any rate, these larger vessels had an average longevity of 58 years, with 89% meeting a final disposition due to natural causes, such as scrapping.

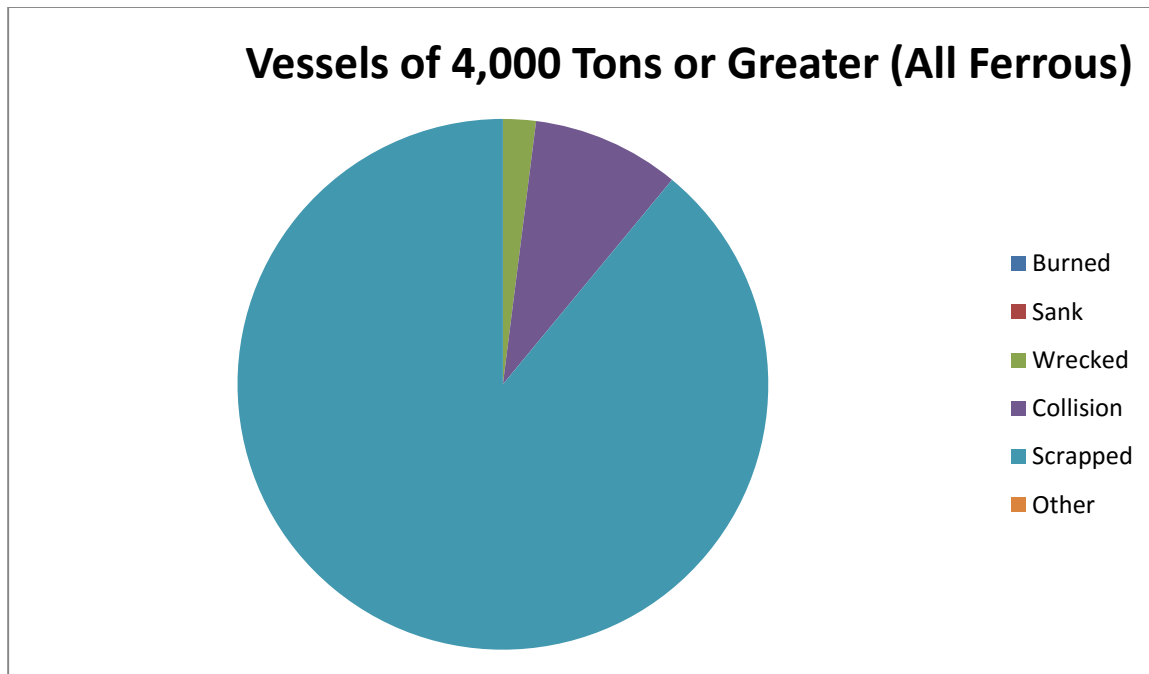

FIGURE 5.7. Cause of loss of vessels of 4000 tons or greater, all ferrous. Average built tonnage: 4796. Average Final tonnage: 4833. All built 1896-1900. Average years: 58. Burn: 0/44. Sank: 0/44 = 0%. Wreck: 1/44 = 2%. Collision: 4/44 = 9%. Scrapped: 39/44 = 89%. Natural causes: 39/44 = 89%. Unnatural causes: 5/44 = 11%.

Twenty six whalebacks were barges. They are presented here, but comparing them directly with steamers is problematic. Unlike ships, barges are not even typically graced with proper names. McDougall's first whaleback, a barge, in which he must have invested a significant amount of pride and joy, as well as most of his money, was christened simply *101*. Even if the resources exist to make a fairly comprehensive list of barges operating on the Lakes in the late nineteenth century, and this is by no means certain, it would require a significant amount of dredging through sources. The data thus harvested would be of the muddiest sort, because bulk trade barges during the transition from wood to steel were such a mixed lot. Many barges were converted sailing vessels, others were ships stripped of their engines at the end of their useful lives, and pressed into a few more years of service. Towards the turn of the century, the popularity of the consort barge model waned, further distorting the picture. Thus, if

comparing bulk freighters is somewhat like comparing apples and oranges, and sometimes bananas as well, comparing the whole inhomogeneous lot of barges would be akin to comparing codfish and cabbages. Whaleback barges are analyzed as a way of filling out a too small pool of whaleback vessels, but it must be recognized that this analyses takes place in a limited context. As can be seen in Figure 5.8, whaleback barges experienced shorter lives and more unnatural losses than any type of powered ship in the data set, even wooden ones.

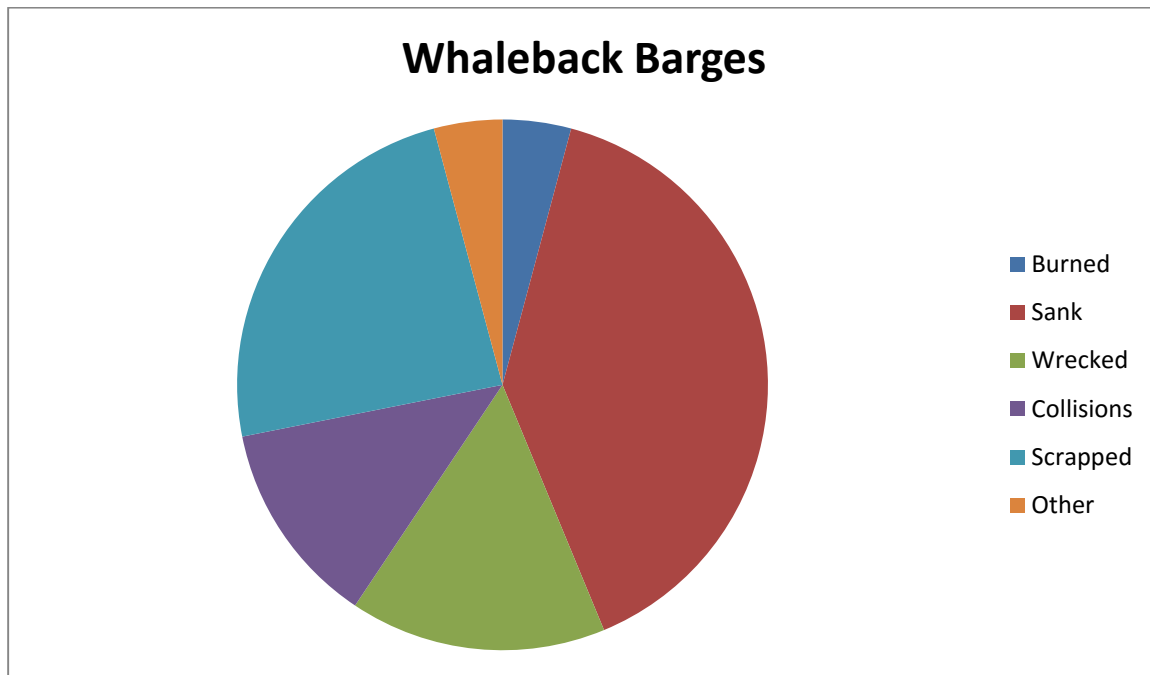

FIGURE 5.8. Cause of loss of whaleback barges: Average tons built: 810. Average final tonnage: 810. Average Lifespan: 18 years. Burn: $1/26 = 4\%$. Sank: $10/26 = 38\%$. Wreck: $4/26 = 15\%$. Collision: $3/26 = 12\%$. Scrapped: $6/26 = 23\%$. Other: $1/26 = 4\%$. Natural causes: $6/26 = 23\%$. Other: $1/25 = 4\%$. Unnatural causes: $18/26 = 69\%$.

As a distinct group of vessels, there is compelling evidence that whalebacks were no less successful than the conventional freighters with which they competed. Although the sample set available is not large enough to preclude all doubt, analysis of the lifespan and cause of loss of all Great Lakes freighters in the latter half of the nineteenth century is highly suggestive. When compared with iron and steel conventional freighters of the same period and of comparable

tonnage, it becomes apparent that whaleback freighters were no more subject to loss and in fact enjoyed slightly longer lifetimes in active service than the conventional freighters. In fact, the most reliable predictor of longevity was found to be tonnage, suggesting that the critical factor in whaleback obsolescence was the failure of ASBC to continue producing whalebacks was that they were made of metal. Nearly a quarter of wooden bulk freighters met their end by fire, compared to none of the ferrous ships. Further, even when losses by fire are excluded, ferrous ships dramatically outperformed wooden ships in key metrics: wooden ships were roughly twice as likely to meet a catastrophic premature end as ferrous ones; ferrous ships had an active service life roughly 50% longer than wooden ones. As Thompson notes, “an average of about 10% of the ships [on the Great Lakes] fell victim to a casualty of one sort or another each season” during the period between 1878 and 1897 (Thompson 2000:22). While the Great Lakes were a dangerous environment, it appears that improvements in shipbuilding did much to ameliorate the danger. A large proportion of these losses could represent the wooden fleet winnowing itself out. As Figure 5.9 shows, the strongest predictors of longevity, barges excluded, were material of construction and tonnage.

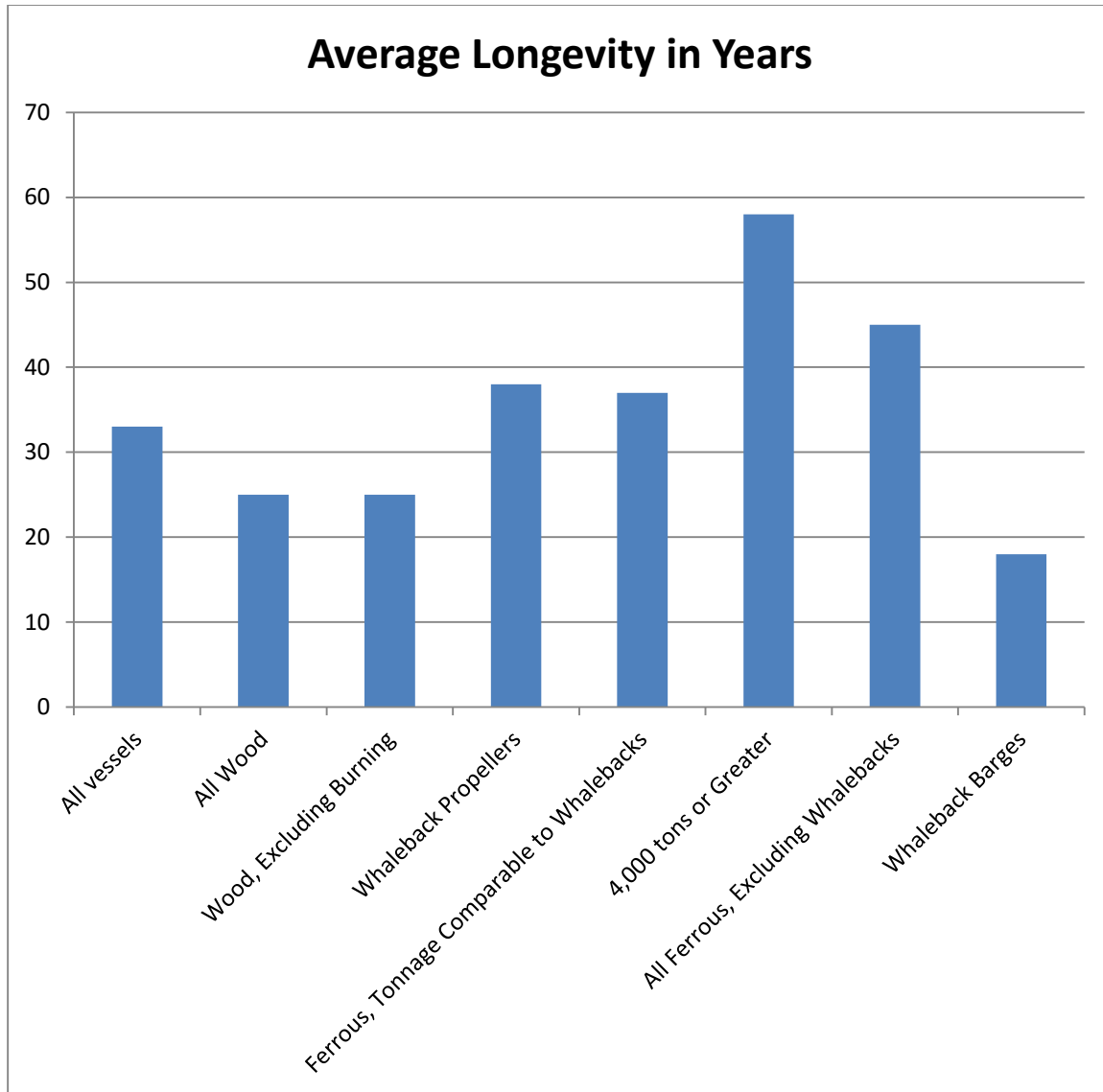

FIGURE 5.9. Average longevity of vessel categories, measured in years. whalebacks long enough to produce a cohort adapted to the new Poe Locks opened at Sault Sainte Marie in 1896. The data further strongly implies that the most remarkable thing about

The clear implication is that the design peculiarities of whalebacks were barely relevant to their performance, at least as measured by their disposition. In the 1880s and early 1890s, any model of ferrous ship was so far superior to the preceding generations of wooden ships that the relative differences between the ferrous models proved inconsequential. The right answer to the question of Great Lakes bulk freighter design was any answer, as long as it was written in steel.

Examining other metrics of performance also implies that whalebacks were substantially comparable to their contemporaries. With a midships coefficient measured at 0.981 for *Frank Rockefeller*, a typical whaleback propeller (Weaver 1960:2), it can be seen that the slightly rounded cross-section did little to impede carrying capacity. As a successor to the “floating boot box” design of *R.J. Hackett*, they were not lacking.

When tested at the Department of the Navy’s David Taylor Model Basin, a model of *Frank Rockefeller* performed very well:

The flow about this hull is considered very good within the speed range within which it was designed to operate. The flow around the bow is smooth, uninterrupted, and almost radial from the centerline. Flow studies indicate a “dead water area” just forward of where the propeller aperture would normally be, from about the 12-foot waterline to the water surface. At speeds above 18 knots the bow wave becomes quite large, as would be expected; however at these speeds the flow about the stern improves (Weaver 1960:2).

McDougall was only really an outlier in the narrow field of Great Lakes shipbuilding:

(Builders) enjoyed an attractive position in the shipbuilding trade because of the limited access to saltwater from the lakes and, in turn, did not have to face the type of domestic and foreign competition which bred progressive innovation. Rather, they were limited by geographic features, by a local or regional trade and as the iron ore fields developed, by the peculiarities of bulk transportation (Wright 1969:2).

McDougall’s whalebacks tend to be taken as far more aberrant than they actually were, in part because Great Lakes shipbuilders have sown such a monoculture. Whalebacks’ underlying vernacularism is masked by the otherwise overwhelming orthodoxy of Great Lakes bulk freighter construction. As has been shown, they performed similarly to their contemporaries in all of the most meaningful ways.

Numerous factors have been cited as leading to the whalebacks' demise: small hatches, internal framing that wasn't readily scalable and small size overall, being some of the most commonly repeated (Zoss 2007:8-9; Wright 1969:52; Devendorf 1995:9; Massie 1990:159). However all of these were issues that arose after the last generation of whalebacks were designed, either as a result of the expansion of the locks at Sault Ste. Marie in 1895/1896 or after the introduction of Hulett Unloaders in 1898 (Daley 2000:61). These challenges were overcome by conventional freighter designers when they arose, and there is nothing inherent in the whaleback design which would prevent them from being overcome there too.

Hatch covers were a continuing weak point in Lakers, traditionally wood planks, covered by canvas tarpaulins. This genuinely ancient system persisted on the Lakes until well into the twentieth century (Thompson 2000: 239-241;334). McDougall's system, a single steel plate, typically about 8 feet by ten feet, bolted over each hatch opening, was unwieldy, and since each had to be moved by hand, inherently limited in size, but it was a tremendous advance over the previous method Daley 2000:60). The telescoping Hatch Cover, patented in 1906 by Joe Kidd, McDougall's former yard supervisor and right hand man, was a major innovation in Great Lakes freighter technology, and might have made whalebacks competitive during the twentieth century (Wright 1969:51-53; US Patent 833058; Figure 5.10).

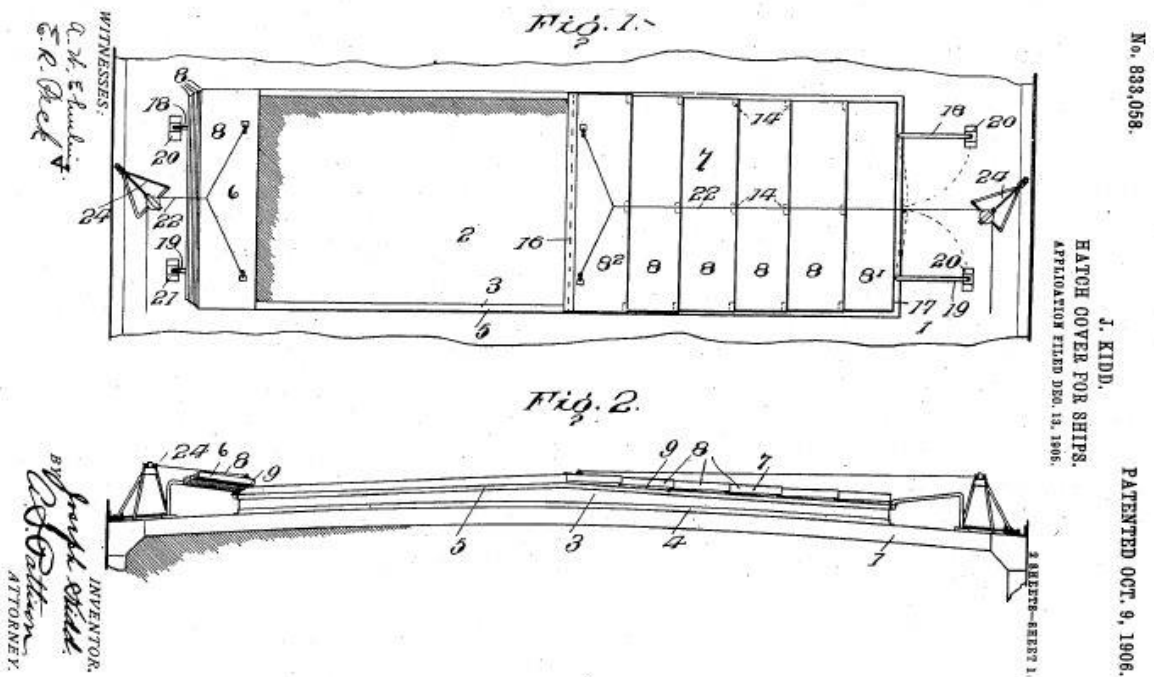

FIGURE 5.10. The Telescoping Hatch Cover (US Patent #833,058, 1906).

The fitting and moving of large single-piece hatch covers was finally addressed with the introduction of the Wood patent hatch cover in 1925. In this system, an overhead deck crane travelling on two fore-and-aft tracks was fitted for the sole purpose of shifting hatch covers (Daley 2000:60-61).

Shore-mounted unloading equipment peaked with the introduction of the Hulett Unloader. The clamshell at the right side of Figure 5.11 was lowered into ships holds by the operator in a small cabin just above. “When Hulett Unloaders entered service in 1898, every vessel on the Great Lakes engaged in the iron ore trade suddenly faced the same problem (Daley 2000:61).” Whalebacks small hatch openings were ill-suited to the monstrous Hulets, a design

parameter that had not been relevant when the ships were built. Had McDougall persisted in developing whalebacks, these shortcomings would likely have been addressed.

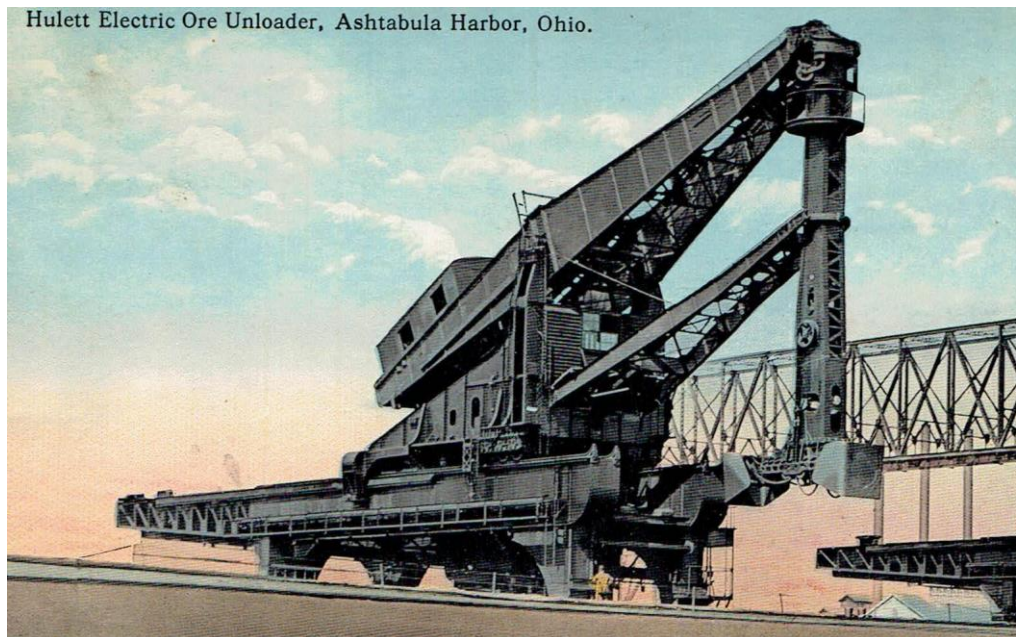

FIGURE 5.11. Hulett Unloader. (Postcard, CT Photographs, Postmarked 1914).

One noteworthy detriment of the whaleback design, apparently unaddressed in the literature was a functional inability to carry a meaningful amount of cargo above the waterline, as when a whaleback was fully laden, its weather deck was barely above water level. Thus, *James B. Colgate*, a whaleback of 308' length, 38' beam, and 24' draft had a cargo capacity of 1713 gross tonnage (Devendorf 1995:80), whereas the conventional freighter *Vega* of almost identical scantlings of 301.2' length, 38.5' beam, and 21.1' draft measured 2144 gross tons (Devendorf 1995: 82). This is a rough comparison, and gross tonnage is a rough measurement, but it is significant that the gross tonnage of the conventional freighter is 25% greater. This is not necessarily to say that the conventional freighter could carry 25% more cargo; regardless of internal volume, a ship and its cargo cannot be heavier than the water they displace. Thus, for a steel ship carrying a very dense cargo like taconite, the effect would have been minimal. For a

less dense cargo, such as grain, the comparative difference in gross tonnage would have mattered more. Conventional freighter did not necessarily maintain a large amount of freeboard when loaded. Figure 5.12 shows whalebacks and conventional freighters side by side. *Bartlett*, far right, was one of the 15 whaleback steamers in the bulk trade, and is flanked by barges *105* and *118* on her port side (Table 1.1; Table 1.2). The wooden freighter *Wallula*, built 1882 (Devendorf 1995:59), is at the left foreground. Note the *Wallula*'s modest amount of freeboard, perhaps eight feet, judging by the figures in frame

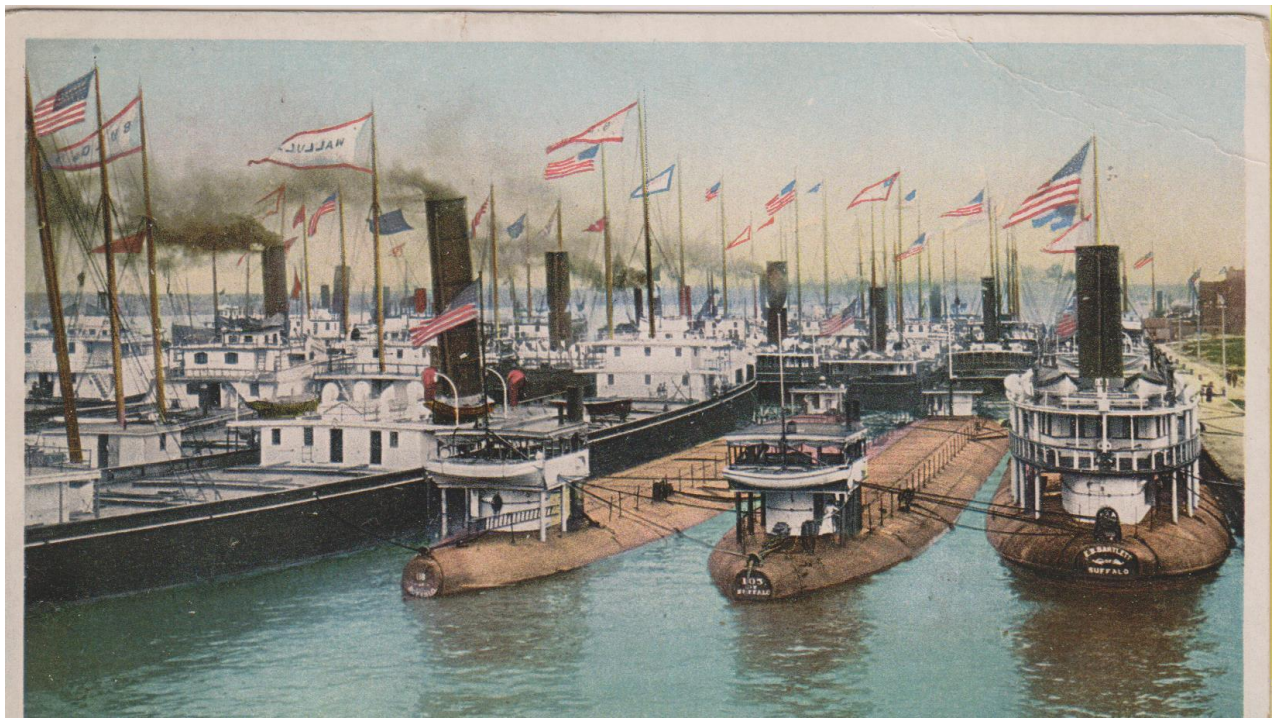

FIGURE 5.12. Ships wait to transit the locks at Sault Ste. Marie (Postcard, Detroit Publishing Company, circa 1900).

This comparative difference in gross tonnage may have been less meaningful in the unsettled framework of Lakes trade at the end of the nineteenth century. Multiple destabilizing elements, including the shift from wooden to ferrous construction technologies, relatively frequent changes in infrastructure, and the consort system complicated direct comparison between vessels. As these unsettling forces subsided and the Great Lakes trade settled into

steady patterns, small differences in incremental carrying capacity between vessels would have become more meaningful, making whalebacks less and less relatively competitive. When the current iterations of the Sault locks were reached, were whalebacks still in production, they presumably would have grown to fill every available inch of the locks, as conventional freighters have. Then, the only direction left in which to grow would have been up, minimizing and probably eventually effacing the difference between whalebacks and conventional freighters. However this sort of reasoning things out to their logical extreme based on only one parameter has obvious limits. The entire saga of whalebacks is shot through with human factors that shaped the ostensibly simple economic question of what shape a ship should be.

Conclusion

When an apple has ripened and falls, why does it fall?
Because of its attraction to the earth, because its stalk withers,
because it is dried by the sun, because it grows heavier,
because the wind shakes it, or because the boy standing below
wants to eat it?

Nothing is the cause. All this is only the coincidence of conditions in which all vital organic and elemental events occur. And the botanist who finds that the apple falls because the cellular tissue decays and so forth is equally right with the child who stands under the tree and says the apple fell because he wanted to eat it and prayed for it. Equally right or wrong is he who says that Napoleon went to Moscow because he wanted to, and perished because Alexander desired his destruction, and he who says that an undermined hill weighing a million tons fell because the last navy struck it for the last time with his mattock. In historic events the so-called great men are labels giving names to events, and like labels they have but the smallest connection with the event itself.

Every act of theirs, which appears to them as an act of their own will, is in an historical sense involuntary and is related to the whole course of history and predestined from eternity (Tolstoy 1915:1244-1245).

While it seems unnecessary to argue here either for or against predestination, it is useful for our attention to rest for a moment on the idea of narrative in history, and how it almost inevitably attaches itself to famous personages. Language, especially written language, structures human thought in a number of ways. Among other things, our minds, pattern recognition devices by nature, have a proclivity for imposing narrative structures on events. We instinctively connect events through perceived causality, and link these events into stories that have a beginning, a middle, and end, and one or more main characters, upon which we pin these events. We weave whatever threads we find into a text that satisfies our need for narrative (Ong 1982).

As seen in Chapter 2, at the height of the Gilded Age, the American narrative emphasized progress through innovation. Whalebacks were largely seen through this lens. Indeed, the expectation of progress may have been an underlying reason that McDougall initially found backing for his project. Further, the tendency of capital to concentrate around wealthy industrialists, and the uniquely empowering patent environment of the time conspired to make McDougall the protagonist of his own narrative in a way which would have been much less possible only a few decades before or a few decades after. He was in the right place at the right time, not only in the world of technology and market forces, but also in the world of narrative expectation. However, viewed from a certain remove, it becomes clear that whalebacks are not wholly explained as the rise and fall of one man and of one design, but as a crest in a continuum, of ideas of vessel design which had their genesis in the introduction of a new shipbuilding medium, and which, in some form, continue up to the present.

As whalebacks have receded into the past, a more ancient and less positive narrative has asserted itself. The absence of whalebacks is extrapolated into their failure as a design, and there

is a whiff of expectation that they must have done so in dramatic fashion. Mariners may function in our thoughts as a sort of universal foreigner, a timeless ‘other,’ and we look on their tragedies with peculiar sangfroid. This there are innumerable books with titles like *Shipwreck*, *Shipwreck!*, *100 Best Great Lakes Shipwrecks*, and so on. These titles apparently do not strike the book-buying public as particularly inappropriate; however, something like *Bus Wreck!*, or *100 Best Airline Crash Sites* would resonate as downright ghoulish. At least part of this must be a cultural expectation that it is natural for ships to wreck and a certain titillation in the spectacle when they do. A ship in a storm is perhaps the most iconic example of the narrative convention of man versus nature; it is hardly surprising that we should come to expect these patterns to play out.

There is seemingly an aversion towards conceiving of these vessels as largely unremarkable in their performance, as evidenced by the author who proclaims “the ships proved themselves to be excellent bulk cargo carriers, able to weather any conditions better than conventional ships could” (Kohl 2007:66-67).

When the *Christian Science Monitor* reported the scrapping of the last whaleback in the Great Lakes bulk trade in 1936, although others carried on in other trades for many years, it offered this analysis:

The advantage of this type of construction over the conventional design now universally followed, was, as far as seamen here can tell, chiefly that it was possible to roll through heavy seas without shipping water. The main reason though, one ‘salt’ insists, is simply that it was an idea, just as the building of automobiles recently with fender skirts was an idea that ‘took on.’ Other builders found no reason to adopt this idea and lake freighters now are of the usual flat deck type (*Christian Science Monitor* 1936:16).

The old salt who insists that it was an idea that took on, a passing fashion, shall have (nearly) the last word, as he is seemingly as right as anyone. Albeit in curves, whalebacks were essentially vernacular, in the context of their time and place.

WORKS CITED

Primary Sources

American Steel Barge Company, Moses E. Clapp, Joseph L. Colby, Hoyt Colgate, Joseph Bell Cotton, Frederick Taylor Gates, M. M. Howland, et al.

1885. *American Steel Barge Company papers*. Unpublished archival material on microfilm: Minnesota Historical Society Library.

1888-1898 *Amship Predecessors: American Steel Barge Company Hulls 102-145/146*. Unpublished archival ships line drawings and plans: Historical Collection of the Great Lakes, Bowling Green State University.

Brassey, Thomas Allnutt

1888 *The Naval Annual*. J. Griffin and Company, Portsmouth, UK.

Calthorp, Samuel R.

1865 Improvement in Construction of Railway Trains and Cars. U.S. Patent 49,227, no filing date listed, issued August 8, 1865.

Christian Science Monitor

1936 Last Whaleback of Great Lakes is Being Junked. *Christian Science Monitor* 15 October:16.

Cornell, Felix M. and Allan C. Hoffman (editors)

1957 *American Merchant Seaman's Manual, Fifth Edition*. Cornell Maritime Press, Centreville, MD.

Crowell and Murray Inc.

1927 *The Iron Ores of Lake Superior: Containing Some Facts of Interest Relating to Mining, Beneficiation and Shipping of the ore and Location of Principal Mines, Sixth edition*. The Penton Press Co, Cleveland, OH.

Doxford, Charles David.

1908 Turret Vessel. U.S. Patent 869,900, filed June 24, 1907, and issued August 25, 1908.

Gates, Frederick Taylor

1977 *Chapters in My Life*. The Free Press, New York, NY.

Goodall, F. C.

1892 Whaleback Steamers. *Transactions of the Royal Institution of Naval Architects* 33:191-206.

Harper's Weekly

1858 The Winans Steamer. *Harper's Weekly* II(95):676-678.

Hawthorne, William Rede and John Christopher Shuldham Shaw.
1961 Vessels for Transporting or Storing Liquids or Fluidisable Solids. U.S. Patent 2,997,973, filed January 6, 1958, and issued August 29, 1961.

Hayler, William B. (editor)
1989 *Merchant Marine Officer's Handbook, Fifth Edition*. Cornell Maritime Press, Centreville, MD.

Kidd, Joseph
1906 Hatch-Cover for Ships. U.S. Patent 833,058, filed December 13, 1905, and issued October 9, 1906.

Knight, Austin M.
1945 *Knight's Modern Seamanship, Eleventh Edition*. D. Van Nostrand Company, New York, NY.

Linblad, Anders Frederick
1924 *A Critical Analysis of the Factors Affecting Safety and Economy of Operation of the Bulk Freight Vessels of the Great Lakes*. The Marine Review, Cleveland, OH.

Los Angeles Times

1892 A Whaleback Excursion Steamer. *Los Angeles Times* 4 December:6. Los Angeles, CA.

McDougall, Alexander

1881 Tow Boat. U.S. Patent 241,813. Filed March 9, 1880, and issued May 24, 1881.

1888 Tow Boat. U.S. Patent 393,997. Filed April 28, 1888, and issued December 4, 1888.

1932 *The Autobiography of Captain Alexander McDougall*. McDougall and Castle, Duluth, MN. Reprinted 1968 by The Great Lakes Historical Society, Cleveland, OH.

Mulrooney, J. M. and F. M. Barton

1896 *Blue Book of American Shipping, 1896*. Marine Review, Cleveland, OH.

Rockefeller, John D. Sr.

1933 *Random Reminiscences of Men and Events*. Doubleday, Doran and Company, Garden City, NY.

Scientific American

1877 Cleopatra's Needle. *Scientific American Supplement*. 28 April:69.

Tunnell, George Gerard

1898 Transportation on the Great Lakes of North America. Doctoral Dissertation, Department of Political Economy, The University of Chicago, Chicago, IL.

United States

1787 *Constitution of the United States*. The Charters of Freedom, <http://www.archives.gov/exhibits/charters/constitution_transcript.html>. Accessed 24 December 2015.

The Washington Post

1891 The “Whaleback” a Success. *The Washington Post* 11 November:4. Washington, DC.

Weaver, A. H. Jr.

Resistance and Flow Data for a Whaleback Steamer Hull Form, Model 4760. Department of the Navy, David Taylor Model Basin. Hydromechanics Laboratory Research and Development Report, Report 1449.

Winans, Ross and Thomas Winans.

1859 Improvement in Hulls of Steam Vessels. U.S. Patent 651, reissued January 25, 1859.

Secondary Sources

Baker, William A., and Tre Tryckare

1965 *The Engine Powered Vessel*. Crescent Books, New York, NY.

Bal, Mieke

1997 *Narratology: Introduction to the Theory of Narrative*, 2nd edition. University of Toronto Press, Toronto, ON.

Barry, James P.

1973 *Ships of the Great Lakes: 300 Years of Navigation*. Howell - North Books, Berkley, CA.

Benford, Harry

1991 *Naval Architecture for Non-Naval Architects*. The Society of Naval Architects and Marine Engineers, Jersey City, NJ.

Bowen, Dana Thomas

1946 *Memories of the Great Lakes*. Freshwater Press, Cleveland, OH.

Chernow, Ron

1997 *The Death of the Banker*. Vintage Books, New York, NY.

1998 *Titan: The Life of John D. Rockefeller, Jr.* Vintage Books, New York, NY.

Clark, Robert

1998 The Advent of the Whalebacks on the Great Lakes. *Nor'easter: Journal of the Lake Superior Marine Museum Association* 23(5):1-5.

Daley, Matthew Lawrence

2000 “Pigs” on the Water: Technological Failure and Great Lakes Shipbuilding Innovation, 1880 – 1905. Master’s Thesis, Department of History, Wayne State University, Detroit, MI.

De Camp, L. Sprague

1961 *The Heroic Age of American Invention*. Doubleday and Company, Garden City, NY.

De Kruif, Paul

1929 *Seven Iron Men*. Harcourt, Brace and Company. New York, NY.

Devendorf, John F.

1995 *Great Lakes Bulk Carriers 1869-1985*. Apollo Printing and Graphics Center, South Bend, IN.

Dickinson, John N.

1981 *To Build a Canal: Saulte Ste. Marie, 1853-1854 and After*. Miami University by The Ohio State University Press, Columbus, OH.

Engman, Elmer

1976 *In the Belly of a Whale*. Innerspace Publishing, Arrowhead Printing Company, Duluth, MN.

Frew, David

2008 *Pigs at Sea: The Sinking of the James B. Colgate*. Print Production, Dispatch Printing, Erie, PA

Galbraith, John Kenneth

1976 *The Affluent Society*, 3rd edition. The New American Library, Inc., New York, NY.

1977 *The Age of Uncertainty*. Houghton Mifflin Company, Boston, MA.

Garreau, Joel

1982 *The Nine Nations of North America*. Avon Books, New York, NY.

Gray, Leonard and John Lingwood

1975 *The Doxford Turret Ships*. The World Ship Society, Kendal, Cumbria, UK.

Guthrie, John

1970 *Bizarre Ships of the Nineteenth Century*. A.S. Barnes and Company, New York, NY.

Harland, John

1984 *Seamanship in the Age of Sail*. Naval Institute Press, Annapolis, MD.

Hatcher, Harlan and Erich A. Walter

1963 *A Pictorial History of the Great Lakes*. Bonanza Books, New York, NY.

Historical Collection of the Great Lakes

2015 Great Lakes Vessel Database, Historical Collection of the Great Lakes, Bowling Green State University, OH <<https://www.bgsu.edu/library/cac/collections/hcgl.html>>. Accessed 2009 through 2015.

Hoyt, Joseph Clayton

2008 The Transition from Wood to Iron in Great Lakes Bulk Carriers: An Historical and Archaeological Investigation of the Wooden Bulk Carrier *Continental*, and early Iron Hulled Bulk Carriers. Master's thesis, Department of History, East Carolina University, Greenville, NC.

Keegan, John

1976 *The Face of Battle*. Penguin Books, New York, NY.

Khan, Zorina

2005 *The Democratization of Invention: Patents and Copyrights in American Economic Development, 1790-1920*. Cambridge University Press, Cambridge, UK.

Kohl, Chris

2007 *The Sagamore: a Whaleback of the Freshwater Seas*. *Wreck Diving Magazine* 14:64-71.

Lafferty, William

1998 Technological Innovation in Great Lakes Shipping: Leathem D. Smith and the Rise of the Self-Unloader, In "*A Fully Accredited Ocean*": *Essays on the Great Lakes*, Victoria Brehm, editor, pp. 155-198. The University of Michigan Press, Ann Arbor, MI.

Larson, Erik

2003 *The Devil in the White City*. Vintage Books, a Division of Random House, New York, NY.

Livingstone, W. A.

1891 *The Great Lakes Problem: or the "Twenty Foot Channel"*. No publisher given, Detroit, MI.

Leggett, Jim

2015 Russia's Revolutionary Round Ship. *PowerShips*, 293. Steamship Historical Society of America, East Providence, RI.

LesStrang, Jacques.

1977 *Lake Carriers: The Saga of the Great Lakes Fleet: North America's Fresh Water Merchant Marine*. Salisbury Press, Seattle, WA.

Lydecker, Ryck

1973 *Pigboat: The Story of the Whalebacks*. Sweetwater Press, Duluth, MN.

Mansfield, J. B.

1899 *History of the Great Lakes: Illustrated in Two Volumes*. J.H. Beers & Co, Chicago, IL. Reprinted 1972 by Freshwater Press, Cleveland, OH.

- Massie, Larry B.
1990 *Pig Boats and River Hogs: Further Voyages into Michigan's Past*. The Priscilla Press, Allegan Forest, MI.
- Mills, James Cooke
1976 *Our Inland Seas: Their Shipping and Commerce for Three Centuries*. Freshwater Press, Cleveland, OH.
- Morris, Charles R.
2005 *The Tycoons: How Andrew Carnegie, John D. Rockefeller, Jay Gould, and J. P. Morgan Invented the American Supereconomy*. Henry Holt and Company, New York, NY.
- Nassaw, David
2006 *Andrew Carnegie*. Penguin Books, New York, NY.
- Ong, Walter
1982 *Orality and Literacy: The Technologizing of the Word*. Rutledge, New York, NY.
- Pellet, C. Roger
2006 *The Machinery of the Steamship Meteor*. C. Roger Pellet, Superior, WI.
- 2007 Drawings for Whaleback Barges and Steamships. *Nautical Research Journal* 53 (3):131-140.
- 2008 Whaleback Steamship *Meteor*: SIA Preservation Grant Update. *Society for Industrial Archaeology Newsletter* 37 (1):4-5.
- Rodgers, Bradley A., and Russell T. Green
2003 *Of Limestone and Labor: Shipwrecks of the Stone Trade: The 1999 Bullhead Point Stone Barge Investigation, Phase II*. East Carolina University, Program in Maritime History and Nautical Archaeology, Research Report No. 11, Greenville, NC.
- Rodgers, Bradley A., James D. Moore III, Annalies Corbin, Jacqueline D. Piero, and Andrew Pietruszka
2006 *From Quarry to Quay: Shipwrecks of McCracken's Cove: The 2001-2002 Sturgeon Bay Wreck and Wharf Investigation at the Birmingham Site*. East Carolina University, Program in Maritime Studies, Research Report No. 17, Greenville, NC.
- Thompson, Mark L.
1991 *Steamboats and Sailors of the Great Lakes*. Wayne State University Press, Detroit, MI.
- 1994 *Queen of the Lakes*. Wayne State University Press, Detroit, MI.
- 2000 *Graveyard of the Lakes*. Wayne State University Press, Detroit, MI.

- Tolstoy, Leo
1915 *War and Peace*. Translator Constance Black. Garnet; Reprint, Plain Label Books, New York, NY.
- Tupper, Eric
2004 *Introduction to Naval Architecture, Fourth Edition*. Elsevier, Butterworth and Heinemann, London, UK.
- Vachon, Paul
2009 *Images of America: Forgotten Detroit*. Arcadia Publishing, Charleston, SC.
- Van Dorn, William G.
1974 *Oceanography and Seamanship*. Dodd, Mead, and Company, New York, NY.
- Von Clausewitz, Karl
1943 *On War*. O. J. Matthijs Jolles, translator. Random House, New York, NY.
- Wicker, Elmus
2000 *Banking Panics of the Gilded Age*. Cambridge University Press, New York, NY.
- Wilson, Erasmus
1878 *Cleopatra's Needle*. Brain and Company, London, UK.
- Wilterding, John H. Jr.
1969 *McDougall's Dream: The American Whaleback*. Badger Bay Printers, Green Bay, WI.
- Wright, Richard J.
1969 *Freshwater Whales: A History of The American Shipbuilding Company and its Predecessors*. Kent State University Press, Kent, OH.
- Zoss, Neel R.
2006 Hull Design and Alteration in Early Whaleback Barges. *Nautical Research Journal* 51(4):212-222.
- 2007 *Images of America: McDougall's Great Lakes Whalebacks*. Arcadia Publishing, Chicago, IL.

APPENDIX A: DATA SET AND COMMENTARY

Data Set Parameters and Methodology:

This data set attempts to compare the longevity of various types of Great Lakes bulk carriers built before 1900. Compiling a data set of this description is attended by certain difficulties. In practice, one may find himself comparing not only apples and oranges, but half of the rest of the produce section as well. There are no graven conclusions here, only trends and suggestions. Let he who cites do so at his own peril, having read the methodology laid out below.

This data set was compiled using Devendorf's *Great Lakes Bulk Carriers* and the Great Lakes Vessel Database maintained by Bowling Green State University as part of the Historical Collection of the Great Lakes (Devendorf 1995:50-94; Historical Collection of the Great Lakes). It thus relies primarily on secondary sources. It was suggested by the data set used in Joseph Hoyt's thesis (Hoyt 2008:204-211) but incorporates a somewhat greater number of ships, and tracks a larger number of variables. Daley, Lydecker, Wilterding and several others list the final disposition of the various vessels in the whaleback fleet, with Daley breaking down these dispositions by cause (Daley 2000:104-105). To the author's knowledge, the longevity and cause of final disposition of whaleback freighters has not been compared statistically with the broader bulk carrier fleet.

The data set is composed of 410 vessels, including 41 of the 44 whaleback vessels built. Of the whalebacks, the *City of Everett*, the *Sagamore*, and the *Christopher Columbus* are excluded, as none operated in the Great Lakes bulk trade. The *City of Everett* was built on the Pacific coast and never operated on the Great Lakes. The whaleback ship *Sagamore*, not to be

confused with the whaleback barge *Sagamore*, was built in and sailed out of England. The *Christopher Columbus* operated solely in the passenger trade.

A relatively broad definition of bulk carrier has been adopted, comprising any vessel which has been identified as working in the bulk trade on the Great Lakes at some point in its career under power. Vessels engaged in the bulk trade for a period which were subsequently retired to other trades, such as lumber carrying, tankering, or car-ferrying are included, on the premise that they retained the same basic build which allowed them to operate in the bulk trade. Exclusively sailing bulk carriers and barges have been omitted as separate beasts, except for the smaller subset of whaleback barges, for reasons explained above. Barges that were later equipped with engines are included in the sample.

A number of vessels were moved off the Great Lakes at some point in their careers. These vessels still appear in the statistics, on the premise that to exclude them from the sample, or to count emigration from the Lakes as a career ending event would distort results more than leaving them in, unfairly penalizing ships that were evidently robust enough to find a buyer. Examination might find that this phenomenon tended to be greatest during wartime, or other periods of high demand. At any rate, it is supposed that it affected all types of ferrous bulk carriers more or less equally, and thus has minimal statistical impact.

Columns in the Data Set are as Follows:

- Name: Only the original name of each vessel is given. As more than a few vessels changed their names several times over their long careers, this streamlines things considerably.

- Construction: Vessels are identified as primarily wood, iron or steel in construction. A small number of bulk carriers were built as composites, wood planks on iron or steel frames. As these were relatively few composite bulk carriers on the Lakes, and a similarly small number of iron bulk carriers, reference will primarily be made to ferrous and non-ferrous vessels.
- Ton (Built): Tonnage as built, measured in gross tons. Gross tons are defined by the appropriate certificating body (i.e. Canadian or American.) Note that in cases of vessels sold over the border, gross tonnage can change as a result of differing standards of admeasurements, but that these changes are generally minor. Tonnage is conventionally expressed in round numbers.
- Ton (Final): Tonnage at time of final disposition. Larger variances usually indicate lengthening or cutting down. On the balance, the difference between built and final tonnage is minor. Note that a vessel might conceivably be built, subsequently lengthened, and finally cut down, and that its intermediate, largest, size would not be represented here.
- Length: Length in feet, as built. All figures are rounded down to the nearest foot, on the premise that the vessels involved are large enough to spare a few inches.
- Launched: Year launched.
- End: Year of final disposition. Final disposition is defined here as a career ending event. Some subjectivity has inevitably become involved, but generally, events which would, for insurance purposes be considered a total loss, such as burning to the waterline, or sinking, have been considered career ending events, even if the vessel or remains thereof were later raised and put to some purpose.

- **Total Years:** The difference between the year of launch and year of final disposition. Note that day and month are not taken into account, thus, for example, a vessel might be launched on December 31, 1899, and sunk on January 1, 1900, and still credited with a full year. The inaccuracies thus introduced are not considered significant.
- **Burn/Sank/Wreck/Collision/Scrapped/Other:** The final disposition of the vessel, as neatly as can be determined. A ship, for example, might run aground, catch on fire and burn to the waterline, drift free and sink, and subsequently be salvaged and rebuilt. In this instance, grounding, as the root cause of the career ending event, would be indicated as the final disposition of the vessel.
- **Burn:** Unintentional fire was the cause of final disposition. Every effort has been made to distinguish between vessels burned intentional as part of the abandonment process and vessels burned unintentionally.
- **Sank:** Vessel sank in open water, for any of a variety of reasons, most typically heavy weather. Intentional grounding to prevent sinking, which resulted in loss, is counted as sinking.
- **Wreck:** Vessel wrecked, grounded, or stranded, or in any other fashion allied with a fixed object.
- **Collision:** Vessel sank as a result of a collision with another vessel.
- **Scrapped:** Vessel was scrapped, abandoned, laid up, or repurposed, recognizing that it had completed its career as a powered vessel without a career ending mishap. Vessels reduced to barges are considered scrapped, on the presumption that they had filled out their useful careers as powered vessels. Repurposing also includes such ends as being sunk as a breakwater or dock, or being used as a floating warehouse.

- Other: Vessels sunk due to enemy action in wartime, or lost by some other anomalous means. In practice, all vessels appearing in the “other” column were lost in wartime.
- Natural? : Whether, as it were, vessel was lost to natural causes, e. g., scrapped or similarly disposed.
- Whale? : Whether vessel is considered a whaleback.
- Comments: Chiefly related to the cause of loss.

Selected Statistics Derived from the Data Set

All Ships (includes whalebacks, excludes barges): Average built tonnage: 2111. Average final tonnage: 2159. Average lifespan: 33 years. Burn: $50/384 = 13\%$. Sank: $62/384 = 16\%$. Wreck: $82/384 = 21\%$. Collision: $36/384 = 9\%$. Scrapped $150/384 = 39\%$. Other: $4/384 = 1\%$. Natural causes: $150/380 = 39\%$. Unnatural causes: $230/380 = 61\%$.

Whaleback propellers: Average tons built: 2006. Average final tonnage: 2097. Average Lifespan: 38 years. Burn $0/15 = 0\%$. Sank: $3/15 = 20\%$. Wreck: $3/15 = 20\%$. Collision: $1/15 = 7\%$. Scrapped: $8/15 = 53\%$. Other $0/15 = 0\%$. Natural: $8/15 = 53\%$. Unnatural causes: 47%.

All wood (no whalebacks) (includes composites.): Average built tonnage: 1495. Average final tonnage: 1532. Average lifespan: 25 years. Burn: $50/230 = 22\%$. Sank: $43/230 = 17\%$. Wreck: $60/230 = 26\%$. Collision: $23/230 = 10\%$. Scrapped: $54/230 = 23\%$. Other: $0/230 = 0\%$. Natural causes: $54/230 = 23\%$. Unnatural causes: $176/230 = 77\%$.

Ferrous, excluding whalebacks (includes steel and iron): Average built tonnage: 3142. Average final tonnage: 3204. Average lifespan: 45 years. Burn: $0/139 = 0\%$. Sank: $16/139 = 12\%$. Wreck: $19/139 = 14\%$. Collision: $12/139 = 9\%$. Scrapped: $88/139 = 63\%$. Other: $4/139 = 3\%$. Natural causes: $88/135 = 65\%$. Unnatural causes: $47/135 = 35\%$.

Ferrous, tonnage comparable to whalebacks (1253 -3686 built tonnage): This excludes only two vessels of tonnage less than whalebacks (i.e. less than 1253.) This excludes fifty vessels of tonnage greater than 3686. Average lifespan: 37 years. Burn: $0/85 = 0\%$. Sank: $16/85 = 19\%$. Wrecked: $17/85 = 20\%$. Collision: $6/85 = 7\%$. Scrapped: $42/85 = 49\%$. Other (War): $4/85 = 5\%$. Natural causes: $42/81 = 52\%$. Unnatural causes: $39/81 = 48\%$.

4k Club: Vessels of 4000 tons or greater, all ferrous. Average built tonnage: 4796. Average Final tonnage: 4833. All built 1896-1900. Average years: 58. Burn: 0/44. Sank: 0/44 = 0%. Wreck: 1/44 = 2%. Collision: 4/44 = 9%. Scrapped: 39/44 = 89%. Natural causes: 39/44 = 89%. Unnatural causes: 5/44 = 11%.

Whaleback Barges: Average tons built: 810. Average final tonnage: 810. Average Lifespan: 18 years. Burn: 1/25 = 4%. Sank: 10/25 = 40%. Wreck: 4/25 = 16%. Collision: 3/12 = 12%. Scrapped: 6/25 = 24%. Other: 1/25 = 4%. Natural causes: 6/24 = 25%. Other: 1/25 = 4%. Unnatural causes: 18/24 = 75%.

Wood, excluding loss by burning (includes composites): Total years: 25. Sank: 43/180 = 24%. Wreck: 61/180 = 34%. Collision: 23/180 = 13%. Scrapped: 53/180 = 30%.

NAME	CONSTRUCTION	TON (BUILT)	TON (FINAL)	LENGTH	LAUNCHED	END	TOTAL YEARS	BURN	SANK	WRECK	COLLISSION	SCRAPPED	OTHER	NATURAL?	WHALE?	COMMENTS
<i>R. J. Hackett</i>	Wood	748	1129	208	1869	1905	36	X						No	No	Coal gas explosion
<i>William T Graves</i>	Wood	804	1075	207	1867	1885	18			X				No	No	Stranded, presumably in storm
<i>Raleigh</i>	Wood	980	1206	227	1871	1911	40			X				No	No	Stranded 1911.
<i>Fred Kelley</i>	Wood	926	770	212	1871	1910	39					X		Yes	No	Engines fitted 1873. Abandoned 1910.
<i>Joseph S. Fay</i>	Wood	882	1220	215	1871	1905	34			X				No	No	Stranded.
<i>W.L. Wetmore</i>	Wood	850	819	215	1871	1901	30			X				No	No	Stranded, Georgian Bay.
<i>H. B. Tuttle</i>	Wood	580	744	179	1871	1906	35			X				No	No	
<i>Mary Jarecki</i>	Wood	502	645	179	1871	1883	12			X				No	No	Wrecked, Point Au Sable
<i>Forest City</i>	Wood	743	1236	216	1870	1904	34			X				No	No	Wrecked, Georgian Bay
<i>Sarah E. Sheldon</i>	Wood	640	907	184	1872	1905	33			X				No	No	Beached, total loss
<i>Persian</i>	Wood	1429	1429	243	1873	1875	2	X						No	No	Burned and Sank
<i>Ohio</i>	Wood	1101	1101	203	1873	1894	21				X			No	No	Collision, sank
<i>Inter Ocean</i>	Wood	1068	1068	213	1872	1905	33					X		Yes	No	Abandoned
<i>Egyptian</i>	Wood	1065	1430	228	1873	1897	24	X						No	No	Burned and Sank
<i>Chauncy Hurlbut</i>	Wood	1009	1009	184	1873	1908	35		X					No	No	Beached to prevent sinking
<i>David Ballentine</i>	Wood	972	1395	221	1873	1901	28			X				No	No	Wrecked, Lorain breakwater
<i>William H. Barnum</i>	Wood	937	1213	218	1873	1894	21		X					No	No	Crushed by ice, sank.

NAME	CONSTRUCTION	TON (BUILT)	TON (FINAL)	LENGTH	LAUNCHED	END	TOTAL YEARS	BURN	SANK	WRECK	COLLISSION	SCRAPPED	OTHER	NATURAL?	WHALE?	COMMENTS
<i>Nahant</i>	Wood	909	1204	213	1873	1897	24	X						No	No	Burned, Escanaba; Abandoned
<i>Selah Chamberlain</i>	Wood	1207	1207	212	1873	1886	13				X			No	No	Collision, Sank.
<i>David W. Rust</i>	Wood	884	884	201	1873	1905	32	X						No	No	Burned, reduced to barge, scrapped 1911.
<i>Cormorant</i>	Wood	872	977	218	1873	1907	34	X						No	No	Burned, Apostle Islands.
<i>Oscar Townsend</i>	Wood	817	1038	192	1873	1891	18	X						No	No	Burned, Port Sanilac
<i>D. M. Wilson</i>	Wood	757	757	179	1873	1894	21		X					No	No	Sank, Thunder Bay, MI.
<i>Geneva</i>	Wood	730	730	191	1873	1873	1		X					No	No	Shaft coupling failure, sank.
<i>Vienna</i>	Wood	745	1006	191	1872	1892	20				X			No	No	Collision, sank
<i>Tecumseh</i>	Wood	633	840	200	1873	1909	26	X						No	No	Burned, Goderich, Ont.
<i>Superior</i>	Wood	586	855	187	1873	1898	25			X				No	No	Beached, Gull Island.
<i>V.H. Ketchum</i>	Wood	1661	1660	233	1874	1904	29					X		Yes	No	Reduced to barge 1904; burned 1905.
<i>James Davidson</i>	Wood	1456	1456	230	1874	1883	9			X				No	No	Wrecked, Thunder Bay, MI.
<i>Charles J Kershaw</i>	Wood	1323	1323	223	1874	1895	21			X				No	No	Wrecked, near Marquette, MI.
<i>E. B. Hale</i>	Wood	1186	1186	217	1874	1897	23		X					No	No	Sank, Pointe aux Barques, Lake Huron
<i>Havanna</i>	Wood	1041	1041	205	1874	1910	36					X		Yes	No	Abandoned, Erie, PA.
<i>Sparta</i>	Wood	1017	1017	202	1874	1919	45			X				No	No	Wrecked, Ford Shoal, Lake Ontario.
<i>N. K. Fairbank</i>	Wood	980	781	205	1874	1904	30	X						No	No	Burned, Sank, Port Sanilac, MI.
<i>V. Swain</i>	Wood	685	955	187	1874	1907	33	X						No	No	Burned, Superior, WI.

NAME	CONSTRUCTION	TON (BUILT)	TON (FINAL)	LENGTH	LAUNCHED	END	TOTAL YEARS	BURN	SANK	WRECK	COLLISSION	SCRAPPED	OTHER	NATURAL?	WHALE?	COMMENTS
<i>H. D. Coffinbury</i>	Wood	649	778	191	1874	1917	43					X		Yes	No	Abandoned, Ashland, WI.
<i>Alcona</i>	Wood	723	952	185	1878	1913	35	X						No	No	To lower St Lawrence, 1911; burned 1913.
<i>Jno. N. Glidden</i>	Wood	1322	1322	221	1879	1903	24				X			No	No	Collision, sank
<i>William Edwards</i>	Wood	1271	1336	226	1879	1917	38		X					No	No	To East Coast 1916, sank 1917
<i>Henry Chisholm</i>	Wood	1775	1775	256	1880	1898	18			X				No	No	Wrecked, Isle Royal
<i>Wocoken</i>	Wood	1400	1400	251	1880	1893	13		X					No	No	Sank off Long Point, Lake Erie.
<i>Hiawatha</i>	Wood	1398	1398	234	1880	1921	41					X		Yes	No	Dismantled 1921
<i>Smith Moore</i>	Wood	1191	1191	223	1880	1889	9				X			No	No	Collision, sank
<i>Minnesota</i>	Wood	1138	1138	206	1880	1903	13	X						No	No	Burned, St Clair River
<i>Argonaut</i>	Wood	1118	1118	213	1873	1906	33	X						No	No	Engines fitted 1880. Burned 1906.
<i>Thomas W. Palmer</i>	Wood	1096	1096	205	1880	1909	29	X						No	No	Burned at dock, Torch Lake, MI.
<i>A. Everett</i>	Wood	1088	1088	211	1880	1895	15		X					No	No	Holed by ice, sank, Pointe aux Barques.
<i>Iron age</i>	Wood	859	1114	226	1880	1909	29	X						No	No	Burned, Detroit River Light.
<i>City of Rome</i>	Wood	1908	1908	268	1881	1914	33	X						No	No	Burned, vicinity of Dunkirk, NY.
<i>Tacoma</i>	Wood	1879	1879	260	1881	1914	33	X						No	No	Burned, Ludington, MI
<i>John B. Lyon</i>	Wood	1710	1710	255	1881	1900	19			X				No	No	Beached, broke in two, vicinity Erie, PA.
<i>Cumberland</i>	Wood	1601	1601	251	1881	1924	43					X		Yes	No	Beached and broken up, Levis, Quebec.

NAME	CONSTRUCTION	TON (BUILT)	TON (FINAL)	LENGTH	LAUNCHED	END	TOTAL YEARS	BURN	SANK	WRECK	COLLISSION	SCRAPPED	OTHER	NATURAL?	WHALE?	COMMENTS
<i>Progress</i>	Wood	1596	1596	255	1880	1905	25		X					No	No	Sank Milwaukee 1905. Later raised as barge.
<i>Oceanica</i>	Wood	1490	1490	262	1881	1919	38	X						No	No	Burned, Montreal.
<i>Rufus P. Ranney</i>	Wood	1392	1392	247	1881	1911	30		X					No	No	Sank 1911, Manitowoc, WI. Raised, rebuilt 1917.
<i>Columbia</i>	Wood	1374	1374	235	1881	1921	40					X		Yes	No	Reduced to barge and abandoned 1921.
<i>Republic</i>	Wood	1343	1343	235	1881	1903	22		X					No	No	Sank, Ashland, WI.
<i>Clyde</i>	Wood	1306	1549	256	1881	1921	40					X		Yes	No	Dismantled, Windsor, Ont.
<i>Jesse H. Farwell</i>	Wood	1200	756	212	1881	1923	42					X		Yes	No	Scuttled 1923.
<i>H. C. Ackley</i>	Wood	1187	1187	231	1881	1883	2		X					No	No	Sank off Saugatuck, MI
<i>Escanaba</i>	Wood	1160	1160	202	1881	1901	20		X					No	No	Sank off Au Sable, MI.
<i>Iron Duke</i>	Wood	1152	1152	212	1881	1920	39			X				No	No	Wrecked, St David, QU.
<i>Brunswick</i>	Iron	1120	1120	236	1881	1881	1				X			No	No	Collision, sank.
<i>Business</i>	Wood	985	985	191	1881	1910	29					X		Yes	No	Abandoned, Erie, PA.
<i>Robert A. Packer</i>	Wood	921	921	209	1881	1907	26	X						No	No	Burned off Coppermine Point, Lake Superior.
<i>Kate Butteroni</i>	Wood	865	865	174	1881	1909	28			X				No	No	Wrecked, South Fox Island, Lake Michigan.
<i>Queen of the West</i>	Wood	818	818	215	1881	1903	22		X					No	No	Sank vicinity Fairport, OH.
<i>Rube Richards</i>	Wood	815	815	175	1881	1905	24					X		Yes	No	Reduced to barge 1905, abandoned 1911.
<i>Sylvannus J. Macy</i>	Wood	548	753	164	1881	1902	21		X					No	No	Sank off Port Burwell, Ont.
<i>Onoko</i>	Iron	2164	2164	287	1882	1915	33		X					No	No	Sank off Knife Island, Lake Superior.

NAME	CONSTRUCTION	TON (BUILT)	TON (FINAL)	LENGTH	LAUNCHED	END	TOTAL YEARS	BURN	SANK	WRECK	COLLISSION	SCRAPPED	OTHER	NATURAL?	WHALE?	COMMENTS
<i>Wallula</i>	Wood	1924	1924	260	1882	1920	38					X		Yes	No	Sold off Lakes 1913. Scrapped 1920, ME.
<i>Siberia</i>	Wood	1618	1618	272	1882	1905	23			X				No	No	Beached vicinity Long Point, Lake Erie.
<i>Colonial</i>	Wood	1501	1501	244	1882	1914	32		X					No	No	Beached to prevent sinking, Rideau, Ont.
<i>Continental</i>	Wood	1506	1506	244	1882	1904	22			X				No	No	Wrecked, Two Rivers Point, Lake Michigan.
<i>Massachusetts</i>	Wood	1415	1530	235	1882	1923	41			X				No	No	Wrecked, Lake St. Louis, St Lawrence River.
<i>Fred Mercur</i>	Wood	1224	1293	232	1882	1925	43	X						No	No	Burned, vicinity of Cornwall, Ont.
<i>Robert Wallace</i>	Wood	1189	1189	209	1882	1902	20		X					No	No	Sank, vicinity of Two Harbors, Minn.
<i>Iron Chief</i>	Wood	1154	1154	212	1881	1904	23		X					No	No	Sank, vicinity of Pointe Aux Barques.
<i>Harry E. Packer</i>	Wood	1142	1183	225	1882	1923	41			X				No	No	Stranded, broke in two, vicinity of Portneuf, Que.
<i>Hecla</i>	Wood	1110	1167	224	1882	1930	48					X		Yes	No	Scrapped, 1930.
<i>M. M. Drake</i>	Wood	1102	1102	201	1882	1901	19				X			No	No	Collision, Sank.
<i>D. C. Whitney</i>	Wood	1090	1440	229	1882	1913	31			X				No	No	Beached 1913. Used as dry-dock until 1920.
<i>John M. Osborn</i>	Wood	646	891	178	1882	1884	2				X			No	No	Collision, sank.
<i>George T Hope.</i>	Wood	1558	1748	263	1883	1912	29		X					No	No	Sank off Grand Island, Lake Superior.
<i>Kitty M. Forbes</i>	Wood	968	968	209	1883	1902	19	X						No	No	Burned, St Clair River
<i>D. D. Calvin</i>	Wood	750	750	166	1883	1910	27	X						No	No	Burned, Garden Island, Ont.

NAME	CONSTRUCTION	TON (BUILT)	TON (FINAL)	LENGTH	LAUNCHED	END	TOTAL YEARS	BURN	SANK	WRECK	COLLISSION	SCRAPPED	OTHER	NATURAL?	WHALE?	COMMENTS
<i>Edward Smith</i>	Wood	700	700	194	1883	1930	47	X						No	No	Burned, Boyne City, MI.
<i>Australasia</i>	Wood	1829	1829	282	1884	1896	12	X						No	No	Burned, vicinity Cana Island, Lake Michigan.
<i>Kasota</i>	Wood	1660	1660	246	1884	1903	19		X					No	No	Sank 1890, raised. Sank 1903, Grand Marais.
<i>City of Cleveland</i>	Wood	1528	1609	255	1882	1901	19			X				No	No	Wrecked, Georgian Bay.
<i>William Chisholm</i>	Iron	1581	1581	246	1884	1916	32			X				No	No	Sold off Lakes 1907. Wrecked 1916.
<i>Calumet</i>	Wood	1526	1526	256	1884	1889	5			X				No	No	Wrecked, vicinity Fort Sheridan, IL.
<i>George Spencer</i>	Wood	1412	1412	230	1884	1905	21			X				No	No	Wrecked, vicinity of Duluth.
<i>Merrimac</i>	Wood	1398	1454	235	1882	1924	42					X		Yes	No	Engines 1884. Abandoned Ogdensburg, NY.
<i>Waldo A. Avery</i>	Wood	1294	1294	240	1884	1893	9	X						No	No	
<i>Monteagle</i>	Wood	1273	1273	213	1884	1909	25			X				No	No	Sank, raised, burned, in quick succession.
<i>J. H. Devereux</i>	Iron	1618	1618	243	1885	1947	62					X		Yes	No	Sold off Lakes 1907, returned 1923. Scrapped 1947.
<i>New Orleans</i>	Wood	1457	1457	231	1885	1906	21				X			No	No	Collision, sank.
<i>A Folsom</i>	Wood	672	449	180	1885	1910	25			X				No	No	Stranded, burned, vicinity of Escanaba.
<i>W. B. Hall</i>	Wood	608	1113	158	1885	1900	5			X				No	No	Wrecked, Blanchard Island, Lake Superior.
<i>Charlemagne Tower Jr.</i>	Wood	1825	1825	255	1886	1914	18		X					No	No	Sold off Lakes 1913. Sank 1914, off Seaside, NJ.

NAME	CONSTRUCTION	TON (BUILT)	TON (FINAL)	LENGTH	LAUNCHED	END	TOTAL YEARS	BURN	SANK	WRECK	COLLISSION	SCRAPPED	OTHER	NATURAL?	WHALE?	COMMENTS
<i>Spokane</i>	Steel	1742	2357	249	1886	1930	44					X		Yes	No	Stranded 1907. Salvaged. Laid up 1930, scrapped 1935.
<i>John F. Eddy</i>	Wood	1678	1678	259	1886	1914	28					X		Yes	No	Reduced to barge 1914, sank 1920.
<i>Lansing</i>	Wood	1611	1611	251	1886	1916	30					X		Yes	No	Sold off Lakes 1913, reported abandoned 1916.
<i>James Pickands</i>	Wood	1546	1546	232	1886	1894	8			X				No	No	Wrecked, Keweenaw Point.
<i>Manhattan</i>	Wood	1545	1545	252	1886	1903	17			X				No	No	Stranded and burned, Grand Island, Lake Superior.
<i>J. H. Outhwaite</i>	Wood	1304	1304	224	1886	1905	21			X				No	No	Stranded and burned, Little Sable Point, Lake Huron.
<i>Veronica</i>	Wood	1093	1124	202	1886	1919	33			X				No	No	Stranded off Port Weller, Ont.
<i>Josephine</i>	Wood	474	775	165	1886	1906	20				X			No	No	Sold off Lakes 1899. Sank, collision, Mobile, AL.
<i>Aurora</i>	Wood	2282	2236	290	1887	1898	11			X				No	No	
<i>Thomas Davidson</i>	Wood	2226	2226	285	1888	1933	45					X		No	No	Abandoned 1933.
<i>William H. Wolf</i>	Wood	2266	2266	285	1887	1921	34	X						No	No	Burned, vicinity Marine City, MI.
<i>Maurice B. Grover</i>	Wood	1996	2147	272	1887	1906	19					X		Yes	No	Reduced to barge 1906, Abandoned 1914.
<i>Yakima</i>	Wood	1986	1986	279	1887	1905	18	X						No	No	Burned and grounded, St Clair River.
<i>Kaliyuga</i>	Wood	1942	1942	269	1887	1905	18		X					No	No	Sank off Presque Isle, Lake Huron.

NAME	CONSTRUCTION	TON (BUILT)	TON (FINAL)	LENGTH	LAUNCHED	END	TOTAL YEARS	BURN	SANK	WRECK	COLLISSION	SCRAPPED	OTHER	NATURAL?	WHALE?	COMMENTS
<i>Missoula</i>	Wood	1927	1927	272	1887	1895	8		X					No	No	Sank vicinity Caribou Island, Lake Superior.
<i>Bulgaria</i>	Wood	1889	1889	280	1887	1915	28			X				Yes	No	Stranded 1906, salvaged. Abandoned 1915.
<i>Cambria</i>	Steel	1878	1878	280	1887	1924	37		X					No	No	Sank off Sturgeon Point, Lake Michigan.
<i>Roumania</i>	Wood	1837	1837	273	1887	1929	42					X		Yes	No	Abandoned 1929.
<i>J. C. Gilchrist</i>	Wood	1827	1827	252	1887	1907	20					X		No	No	Laid up after 1907. Final disposition unclear.
<i>Louisiana</i>	Wood	1753	1753	267	1887	1913	26			X				No	No	
<i>Ira H. Owen</i>	Steel	1753	1753	262	1887	1905	18		X					No	No	Sank, vicinity Caribou Island, Lake Superior.
<i>Fayette Brown</i>	Wood - C	1743	2081	252	1887	1928	41					X		Yes	No	Scrapped 1928.
<i>E. M. Peck</i>	Wood - C	1809	1651	252	1888	1934	46					X		Yes	No	Boiler exploded 1913, repaired; sold for scrap 1934
<i>Sitka</i>	Wood	1741	1741	272	1887	1904	17			X				No	No	Stranded off Grand Marais, MI.
<i>Frank L. Vance</i>	Wood	1732	1732	257	1887	1910	23	X						No	No	Burned, vicinity Ludington, MI.
<i>Iron King</i>	Wood	1703	1748	252	1887	1921	34					X		Yes	No	Scrapped 1921, Erie, PA.
<i>Charles J. Sheffield</i>	Steel	1700	1700	259	1887	1889	2				X			No	No	Collision, sank, vicinity Whitefish Point.
<i>William H. Gratwick</i>	Wood	1688	1688	265	1887	1926	39					X		Yes	No	Abandoned Ecorse, MI.
<i>F. W. Wheeler</i>	Wood	1688	1688	265	1887	1893	6			X				No	No	Stranded, vicinity Michigan City, IN.
<i>Gogebic</i>	Wood	1681	1681	227	1887	1921	34					X		Yes	No	Reduced to barge 1921, scuttled 1932.

NAME	CONSTRUCTION	TON (BUILT)	TON (FINAL)	LENGTH	LAUNCHED	END	TOTAL YEARS	BURN	SANK	WRECK	COLLISION	SCRAPPED	OTHER	NATURAL?	WHALE?	COMMENTS
<i>Wiley M. Egan</i>	Wood	1677	1620	252	1887	1915	28					X		Yes	No	Reduced to barge 1915; later sunk for dock.
<i>R. P. Fitzgerald</i>	Wood	1682	1682	256	1887	1931	44					X		Yes	No	Abandoned 1931.
<i>Roswell P. Flower</i>	Wood	1593	1593	264	1887	1918	31			X				No	No	Stranded Drummond Island.
<i>Horace A. Tuttle</i>	Wood	1585	1585	250	1887	1898	11			X				No	No	Wrecked, vicinity Michigan City, IN.
<i>Samuel Mather</i>	Wood	1576	1576	246	1887	1891	4				X			No	No	Collision, sank, Whitefish Bay.
<i>Robert R. Rhodes</i>	Wood	1576	1599	246	1887	1921	34		X					No	No	Sank Welland Canal.
<i>Gettysburg</i>	Wood	1358	1358	208	1887	1919	33		X					No	No	Sold off Lakes 1916. Sank 1919, Tybee Light, GA.
<i>Omaha</i>	Wood	1231	1251	215	1887	1925	38					X		Yes	No	Scuttled 1925.
<i>Chenango</i>	Wood	938	938	175	1887	1890	3	X						No	No	Burned and scuttled 1890. Rebuilt. Burned 1907.
<i>Corona</i>	Steel	2408	2517	299	1888	1940	52					X		Yes	No	
<i>Corsica</i>	Steel	2364	2364	299	1888	1926	38					X		Yes	No	Sold off Lakes 1917. Scrapped 1926.
<i>Alfred P. Wright</i>	Wood	2207	2207	286	1888	1915	27	X						No	No	Burned, Portage Waterway, Lake Superior.
<i>Gladstone</i>	Wood	2112	2112	283	1888	1923	35					X		Yes	No	Abandoned 1923
<i>Helena</i>	Wood	2083	2083	275	1888	1918	30			X				No	No	Stranded, total loss.
<i>George G. Hadley</i>	Wood	2073	2073	287	1888	1902	14				X			No	No	Collision, sank 1902. Later raised, converted to barge.

NAME	CONSTRUCTION	TON (BUILT)	TON (FINAL)	LENGTH	LAUNCHED	END	TOTAL YEARS	BURN	SANK	WRECK	COLLISSION	SCRAPPED	OTHER	NATURAL?	WHALE?	COMMENTS
<i>John Craig</i>	Wood	2044	2044	275	1888	1906	18			X				No	No	Stranded 1903, salvaged. Wrecked 1906.
<i>Phillip Minch</i>	Wood	1988	1988	275	1888	1904	16	X						No	No	Burned and sank vicinity of Mddle Island, Lake Erie.
<i>Neosho</i>	Wood	1982	1982	266	1888	1894	6			X				No	No	Wrecked Spectacle Reef, Lake Huron. Later Salvaged.
<i>Volunteer</i>	Wood	1944	1944	270	1888	1914	26					X		Yes	No	Abandoned and burned near Milwaukee.
<i>Pascal P. Pratt</i>	Wood	1927	1927	272	1888	1908	20	X						No	No	Burned and sank vicinity of Long Point, Lake Erie.
<i>William B. Morley</i>	Wood	1846	2167	277	1888	1918	30			X				No	No	Wrecked vicinity of Grand Marais, MI.
<i>George W. Roby</i>	Wood	1843	1843	281	1888	1906	18			X				No	No	Grounded, burned, sank; abandoned 1906.
<i>Tom Adams</i>	Wood	1810	1810	281	1888	1910	22	X						No	No	Burned at anchor, Lake Superior
<i>Robert L. Fryer</i>	Wood	1810	1810	281	1888	1914	26	X						No	No	Burned, Marine City, MI.
<i>Algonquin</i>	Steel	1806	1805	245	1888	1917	29						X	War	No	Sold off Lakes 1916. Torpedoed 1917.
<i>Robert Mills</i>	Wood	1790	1790	256	1888	1929	41					X		Yes	No	Abandoned 1929.
<i>Mecosta</i>	Wood	1776	1776	281	1888	1922	34		X					No	No	Sank off Rocky River, OH.
<i>Specular</i>	Wood	1741	1741	263	1882	1900	8				X			No	No	Fitted with engines 1888. Collision, sank 1900.
<i>J. Emory Owen</i>	Wood	1739	1264	256	1888	1909	21		X					No	No	Sank Lake Erie, 1909.

NAME	CONSTRUCTION	TON (BUILT)	TON (FINAL)	LENGTH	LAUNCHED	END	TOTAL YEARS	BURN	SANK	WRECK	COLLISSION	SCRAPPED	OTHER	NATURAL?	WHALE?	COMMENTS
<i>Charles Steward Parnell</i>	Wood	1739	1739	256	1888	1905	17	X						No	No	Burned and sank, vicinity Squaw Island, Lake Michigan.
<i>Henry J. Johnson</i>	Wood	1713	1713	260	1888	1902	14				X			No	No	Collision, sank, Nine Mile Point, Lake Michigan.
<i>Servia</i>	Wood	1425	1425	242	1888	1898	10	X						No	No	Burned and Sank, vicinity of Whitefish Point.
<i>Susan E. Peck</i>	Wood - C	1399	1808	230	1886	1933	47					X		Yes	No	Fitted with Engines 1888. Scrapped 1933.
<i>George H. Dyer</i>	Wood	1372	1372	208	1888	1926	38					X		Yes	No	Abandoned 1926.
<i>John Rugee</i>	Wood	1216	1216	216	1888	1925	37	X						No	No	Burned at Ogdensburg.
<i>Germanic</i>	Wood	1131	1131	216	1888	1909	21	X						No	No	Burned, Georgian Bay.
<i>Elfin-Mere</i>	Wood	1054	676	190	1888	1906	18			X				No	No	Wrecked on wreck of <i>Armenia</i> .
<i>George W. Morley</i>	Wood	1044	1044	192	1888	1897	9	X						No	No	Burned off Evanston, IL.
<i>Britannic</i>	Wood	1021	1319	219	1888	1926	38	X						No	No	Burned Kingston.
<i>Castalia</i>	Steel	2512	3125	292	1889	1919	30		X					No	No	To ocean 1917, broke in half, sank.
<i>Pontiac</i>	Steel	2298	2298	300	1889	1917	28			X				No	No	Wrecked near Loyal Island, Lake Huron.
<i>James C. Lockwood</i>	Wood	2278	2278	286	1889	1917	28		X					No	No	Sprang a leak; caught fire while being abandoned.
<i>Neshoto</i>	Wood	2255	2255	284	1889	1908	19			X				No	No	Wrecked Crisp Point, Lake Superior.
<i>America</i>	Steel	2171	2152	274	1889	1923	34			X				No	No	Wrecked Georgian Bay.

NAME	CONSTRUCTION	TON (BUILT)	TON (FINAL)	LENGTH	LAUNCHED	END	TOTAL YEARS	BURN	SANK	WRECK	COLLISSION	SCRAPPED	OTHER	NATURAL?	WHALE?	COMMENTS
<i>Brazil</i>	Steel	2186	2186	276	1890	1943	53					X		Yes	No	Abandoned 1943. Scrapped 1949.
<i>Manchester</i>	Wood - C	2132	1778	281	1889	1956	67					X		Yes	No	Laid up 1956, Scrapped 1960.
<i>John Owen</i>	Wood - C	2127	2127	281	1889	1919	30		X					No	No	Sank, vicinity Caribou Island, Lake Superior.
<i>Thomas W. Palmer</i>	Wood - C	2134	2134	281	1889	1905	16				X			No	No	Collision, sank.
<i>Charles A. Eddy</i>	Wood	2075	2075	281	1889	1918	29					X		Yes	No	Dismantled 1918.
<i>Olympia</i>	Wood	2065	2065	276	1889	1918	29					X		Yes	No	Broken up 1918.
<i>C. W. Elphicke</i>	Wood	2058	2058	273	1889	1913	24		X					No	No	Beached to prevent sinking, broke in two.
<i>Italia</i>	Wood	2036	2305	289	1889	1915	26					X		Yes	No	Cut down to barge 1915, broken up 1920.
<i>Frontenac</i>	Steel	2003	2003	270	1889	1924	35					X		Yes	No	Sold off Lakes 1919; scrapped 1924.
<i>Phillip D. Armour</i>	Wood	1991	1991	264	1889	1915	26					X		Yes	No	Reduced to barge, sank same year.
<i>Majestic</i>	Wood	1986	1986	291	1889	1907	18	X						No	No	Burned, vicinity Long Point.
<i>George Presley</i>	Wood	1936	1936	265	1889	1905	16			X				No	No	Wrecked and burned, Green Bay.
<i>Nyanza</i>	Wood	1888	1888	280	1890	1919	29		X					No	No	Sank, 1919.
<i>George F. Williams</i>	Wood	1888	1888	280	1890	1913	23					X		Yes	No	Abandoned 1913
<i>John Mitchell</i>	Wood	1864	2149	283	1889	1923	34	X						No	No	Burned 1923.
<i>Griffin</i>	Steel	1856	1445	266	1891	1970	79					X		Yes	No	Sold for scrap 1970.
<i>Joliet</i>	Steel	1921	1921	266	1890	1911	21				X			No	No	Collision, sank 1911.
<i>La Salle</i>	Steel	1921	1921	266	1889	1961	72					X		Yes	No	Sold for scrap 1961.

NAME	CONSTRUCTION	TON (BUILT)	TON (FINAL)	LENGTH	LAUNCHED	END	TOTAL YEARS	BURN	SANK	WRECK	COLLISION	SCRAPPED	OTHER	NATURAL?	WHALE?	COMMENTS
<i>Wawatam</i>	Steel	1856	1880	266	1890	1937	47					X		Yes	No	Scrapped 1937.
<i>Fedora</i>	Wood	1848	1848	282	1889	1901	12	X						No	No	Burned, beached.
<i>John Plankington</i>	Wood	1821	1821	267	1889	1917	28				X			No	No	Collision, sank.
<i>Passadena</i>	Wood	1760	1982	250	1889	1906	17			X				No	No	Wrecked, Keweenaw Waterway.
<i>Vulcan</i>	Steel	1759	1799	260	1889	1944	55					X		Yes	No	Scrapped 1944.
<i>Parks Foster</i>	Steel	1729	1774	262	1889	1960	71					X		Yes	No	Scrapped 1960.
<i>Topeka</i>	Wood	1376	1376	228	1889	1916	27				X			No	No	Collision, sank, Detroit River.
<i>Cherokee</i>	Wood	1304	1057	208	1889	1920	31		X					No	No	Sank, Welland Canal. Later raised and rebuilt.
<i>Marion</i>	Wood	1206	930	217	1889	1926	37	X						No	No	Burned and sank.
<i>Oscar T. Flint</i>	Wood	824	1126	218	1889	1909	20	X						No	No	Burned and sank, vicinity Thunder Bay, MI.
<i>Fred Pabst</i>	Wood	2143	2143	287	1890	1907	17				X			No	No	Collision, sank, St Clair River. Later raised as barge.
<i>Maryland</i>	Steel	2419	2419	316	1890	1916	26		X					No	No	Sold off Lakes, sank 1916.
<i>W. H. Gilcher</i>	Steel	2415	2415	301	1890	1892	2		X					No	No	Sank Lake Michigan.
<i>Emily P. Weed</i>	Steel	2363	3168	300	1890	1905	15			X				No	No	Wrecked, Lake Superior.
<i>Western Reserve</i>	Steel	2392	2392	300	1890	1892	2		X					No	No	Sank, vicinity Whitefish Point.
<i>Briton</i>	Steel	2348	2348	296	1890	1929	39			X				No	No	Sold off Lakes 1917, returned 1923. Wrecked 1929.
<i>Germanic</i>	Steel	2348	2348	296	1890	1919	29				X			No	No	Sold off Lakes 1918. Collision, sank, 1919.

NAME	CONSTRUCTION	TON (BUILT)	TON (FINAL)	LENGTH	LAUNCHED	END	TOTAL YEARS	BURN	SANK	WRECK	COLLISSION	SCRAPPED	OTHER	NATURAL?	WHALE?	COMMENTS
<i>Grecian</i>	Steel	2348	2348	296	1890	1906	16			X				No	No	Grounded. Subsequently sunk under tow to shipyard.
<i>Norman</i>	Steel	2304	2304	296	1890	1895	5				X			No	No	Collision, sank.
<i>Roman</i>	Steel	2348	2348	296	1890	1919	29		X					No	No	
<i>Saxon</i>	Steel	2348	2348	296	1890	1927	37					X		Yes	No	Sold off Lakes 1918. Scrapped 1927.
<i>S. R. Kirby</i>	Steel	2339	2339	294	1890	1916	26		X					No	No	Sank vicinity Eagle Harbor, MI.
<i>Manola</i>	Steel	2326	2326	282	1890	1924	34			X				No	No	Wrecked 1924, Georgian Bay.
<i>Mariska</i>	Steel	2326	3072	283	1890	1959	69					X		Yes	No	
<i>Maruba</i>	Steel	2311	2311	290	1890	1934	44					X		Yes	No	Sold off Lakes 1917; returned 1925. Scrapped 1934.
<i>Matoa</i>	Steel	2311	2723	290	1890	1937	47					X		Yes	No	Wrecked 1913, salvaged. Scrapped 1937.
<i>Republic</i>	Steel	2316	2991	291	1890	1925	35					X		Yes	No	Sold off Lakes 1918. Scrapped 1925.
<i>C. B. Lockwood</i>	Wood	2139	2139	285	1890	1902	12		X					No	No	Sank vicinity Fairport, OH.
<i>C. F. Bielman</i>	Wood	2056	2056	291	1892	1926	34					X		Yes	No	Barge 1917-1918. Laid up 1926 and abandoned.
<i>L. R. Doty</i>	Wood	2056	2056	291	1893	1898	5		X					No	No	Sank vicinity Milwaukee.
<i>Iosco</i>	Wood	2052	2052	291	1891	1905	14		X					No	No	Sank off Huron Island, Lake Superior
<i>William F. Sauber</i>	Wood	2053	2053	291	1891	1903	12		X					No	No	Sank, vicinity Whitefish Point.
<i>Tampa</i>	Wood	1972	1972	291	1890	1911	21				X			No	No	

NAME	CONSTRUCTION	TON (BUILT)	TON (FINAL)	LENGTH	LAUNCHED	END	TOTAL YEARS	BURN	SANK	WRECK	COLLISSION	SCRAPPED	OTHER	NATURAL?	WHALE?	COMMENTS
<i>Uganda</i>	Wood	2054	2054	291	1892	1913	21		X					No	No	Sank, Lake Michigan.
<i>John Harper</i>	Wood	1952	1952	298	1890	1914	24		X					No	No	Sank, Detroit River.
<i>Alex Nimick</i>	Wood	1969	1969	298	1890	1907	17		X					No	No	Beached to prevent sinking.
<i>John W. Moore</i>	Steel	1962	1962	246	1890	1944	54					X		Yes	No	Scrapped 1944.
<i>R. E. Schuck</i>	Wood	1868	1868	265	1890	1913	23			X				No	No	Grounded and burned, Green Bay.
<i>J. H. Wade</i>	Steel	1863	2301	265	1890	1926	36					X		Yes	No	Sold off Lakes 1918. Scrapped 1926.
<i>Hesper</i>	Wood	1859	1859	250	1890	1905	15			X				No	No	Wrecked, Beaver Bay, Lake Superior.
<i>John Oades</i>	Wood	1455	1455	212	1890	1925	35					X		Yes	No	Reduced to barge 1925. Later abandoned.
<i>St Lawrence</i>	Wood	1437	1437	239	1890	1898	8			X				No	No	Wrecked vicinity Point Betsie, Lake Michigan.
<i>Hiram W. Sibley</i>	Wood	1419	1419	221	1890	1898	8			X				No	No	Grounded, broke up.
<i>Byron Whitaker</i>	Wood	1405	1538	220	1890	1920	30	X						No	No	Burned 1920.
<i>Panther</i>	Wood	1373	1634	237	1890	1916	26				X			No	No	Collision, sank, Whitefish Bay.
<i>Denver</i>	Wood	1295	1103	222	1890	1937	47					X		Yes	No	Last listed 1937. Presumed abandoned.
<i>Ionia</i>	Wood	1287	1367	209	1890	1925	35					X		Yes	No	Scuttled 1925.
<i>Colgate Hoyt</i>	Steel	1253	1253	276	1890	1909	19			X				No	Yes	Off Lakes 1906. Wrecked 1909, NJ.
<i>Joseph L. Colby</i>	Steel	1245	1245	265	1890	1935	45					X		Yes	Yes	Periodically off Lakes. Scrapped 1935.
<i>E. C. Pope</i>	Steel	2637	2637	317	1891	1953	62					X		Yes	No	Off Lakes 1918 - 1923. Scrapped 1953.

NAME	CONSTRUCTION	TON (BUILT)	TON (FINAL)	LENGTH	LAUNCHED	END	TOTAL YEARS	BURN	SANK	WRECK	COLLISSION	SCRAPPED	OTHER	NATURAL?	WHALE?	COMMENTS
<i>Ferdinand Schlessinger</i>	Wood	2608	2608	305	1891	1919	28		X					No	No	Sank, vicinity Passage Island, Lake Superior.
<i>Marina</i>	Steel	2432	2410	292	1891	1917	26			X				No	No	Wrecked 1917.
<i>Masaba</i>	Steel	2432	1913	292	1891	1924	33					X		Yes	No	Off Lakes 1918. Presumed scrapped 1924.
<i>City of Berlin</i>	Wood	2051	2051	298	1891	1925	34			X				No	No	Grounded, subsequently abandoned.
<i>City of Genoa</i>	Wood	2110	2110	301	1892	1911	19				X			No	No	Collision, sank, St Clair River.
<i>City of Glasgow</i>	Wood	2003	2003	297	1891	1907	16			X				No	No	Grounded and burned, Green Bay.
<i>City of London</i>	Wood	2006	2006	297	1891	1913	22				X			No	No	Collision, sank.
<i>City of Naples</i>	Wood	2109	2109	301	1892	1919	27	X						No	No	Burned and sank.
<i>City of Paris</i>	Wood	2063	2063	298	1891	1929	38					X		Yes	No	Reduced to barge.
<i>City of Venice</i>	Wood	2108	2108	301	1892	1902	10				X			No	No	Collision, sank.
<i>E. B. Bartlett</i>	Steel	1400	1400	265	1891	1916	25		X					No	Yes	Off Lakes 1905, sank 1916, Cape Cod Canal.
<i>A. D. Thompson</i>	Steel	1400	1400	265	1891	1936	45					X		Yes	Yes	Off Lakes 1905-1922. Scrapped 1936.
<i>Pueblo</i>	Wood	1349	1493	225	1891	1926	35	X						No	No	Burned and scuttled.
<i>John Duncan</i>	Wood	1268	1517	225	1891	1919	28				X			No	No	Damaged in collision, abandoned.
<i>Mariposa</i>	Steel	2831	2831	330	1892	1944	52					X		Yes	No	Laid up 1944, subsequently scrapped.
<i>Maritana</i>	Steel	2957	2957	330	1892	1947	55					X		Yes	No	Scrapped 1947.
<i>Selwyn Eddy</i>	Steel	2846	2846	343	1892	1945	53					X		Yes	No	Straightback. Off Lakes 1916.
<i>Pathfinder</i>	Steel	2425	2425	340	1892	1933	41					X		Yes	Yes	Sold for scrap 1933.

NAME	CONSTRUCTION	TON (BUILT)	TON (FINAL)	LENGTH	LAUNCHED	END	TOTAL YEARS	BURN	SANK	WRECK	COLLISSION	SCRAPPED	OTHER	NATURAL?	WHALE?	COMMENTS
<i>Thomas Maytham</i>	Steel	2330	2330	286	1892	1942	50						X	War	No	Off Lakes 1942, Torpedoed 1942.
<i>Samuel Mitchell</i>	Steel	2278	2379	292	1892	1974	82					X		Yes	No	Reduced to barge 1974. Scrapped 1994.
<i>W. B. Morley</i>	Wood	1748	1913	240	1892	1922	30			X				No	No	Wrecked, Thousand Islands.
<i>James B. Colgate</i>	Steel	1713	1713	308	1892	1916	24		X					No	Yes	Sank, Lake Erie.
<i>Samuel Mather</i>	Steel	1713	1713	308	1892	1924	32		X					No	Yes	Sank, Lake Huron.
<i>Iroquois</i>	Wood	1699	1769	242	1892	1930	38					X		Yes	No	Dismantled 1930.
<i>Andaste</i>	Steel	1574	1574	266	1892	1929	38		X					No	No	Straightback. Sank, Lake Michigan.
<i>Choctaw</i>	Steel	1574	1574	266	1892	1916	24				X			No	No	Straightback. Sank, Lake Huron.
<i>Cadillac</i>	Steel	1264	1297	230	1892	1922	30			X				No	No	Wrecked, Keweenaw Waterway.
<i>Pioneer</i>	Steel	1124	1079	226	1892	1917	25				X			No	No	
<i>John J. Hill</i>	Wood	974	974	170	1892	1903	11		X					No	No	Off Lakes 1901. Abandoned at sea 1903.
<i>Centurion</i>	Steel	3402	3402	360	1893	1945	53					X		Yes	No	Laid up 1945, scrapped 1947.
<i>S. S. Curry</i>	Steel	3260	3931	360	1893	1937	44					X		Yes	No	Scrapped 1937.
<i>Merida</i>	Steel	3261	3329	360	1893	1916	23		X					No	No	Sank, Long Point.
<i>Thomas Cranage</i>	Wood	2220	2220	305	1893	1911	18			X				No	No	Wrecked, Georgian Bay.
<i>Yuma</i>	Steel	2195	2195	322	1893	1933	40					X		Yes	No	Straightback. Off Lakes 1918. Barge 1933. Sank 1949.
<i>Vega</i>	Steel	2144	2144	301	1893	1905	12			X				No	No	Wrecked, Lake Michigan.

NAME	CONSTRUCTION	TON (BUILT)	TON (FINAL)	LENGTH	LAUNCHED	END	TOTAL YEARS	BURN	SANK	WRECK	COLLISSION	SCRAPPED	OTHER	NATURAL?	WHALE?	COMMENTS
<i>George Stone</i>	Wood	1841	1841	270	1893	1909	16			X				No	No	Stranded and burned, Pelee Passage.
<i>Bannockburn</i>	Steel	1620	1620	245	1893	1902	9		X					No	No	Missing 1902, presumed sunk.
<i>Harvey H. Brown</i>	Steel	2674	2674	351	1894	1927	33					X		Yes	No	Off Lakes 1916. Scrapped 1927.
<i>I. W. Nicholas</i>	Steel	2624	1889	328	1894	1937	43					X		Yes	No	Off Lakes 1916 - 1922. Scrapped 1937.
<i>Shenandoah</i>	Wood	2252	2252	308	1894	1924	30					X		Yes	No	Abandoned, Bay City.
<i>Madagascar</i>	Wood	1203	1203	241	1894	1909	15		X					No	No	Off lakes 1907. Sank 1909.
<i>Nicaragua</i>	Wood	1202	1202	241	1894	1921	27					X		Yes	No	Laid up 1921, scrapped.
<i>Victory</i>	Steel	3775	4527	387	1895	1969	74					X		Yes	No	Sunk for breakwater 1969
<i>Zenith City</i>	Steel	3850	3850	387	1895	1947	52					X		Yes	No	Scrapped 1947.
<i>W. D. Rees</i>	Steel	3760	3760	387	1895	1956	61					X		Yes	No	Scrapped 1956.
<i>Penobscot</i>	Steel	3503	4077	351	1895	1955	60					X		Yes	No	Used for storage after 1955. Scrapped 1963.
<i>Yale</i>	Steel	3453	3453	371	1895	1933	38			X				No	No	Stranded 1933, salvaged for scrap.
<i>John J. McWilliams</i>	Steel	3400	3400	352	1895	1928	33			X				No	No	Wrecked, Cana Island, Lake Michigan.
<i>Chili</i>	Steel	2584	2656	320	1895	1943	48			X				No	No	Wrecked Point Isabel, Lake Superior.
<i>Rappahannock</i>	Wood	2381	2381	308	1895	1911	16			X				No	No	Wrecked, Jackfish Bay, Lake Superior.
<i>Sacramento</i>	Wood	2381	2381	308	1895	1939	44					X		Yes	No	Abandoned, Bay City.
<i>Scottish Hero</i>	Steel	2202	2202	297	1895	1917	22						X	War	No	Turret. To Lakes 1907-1917. Sunk by enemy 1917.

NAME	CONSTRUCTION	TON (BUILT)	TON (FINAL)	LENGTH	LAUNCHED	END	TOTAL YEARS	BURN	SANK	WRECK	COLLISSION	SCRAPPED	OTHER	NATURAL?	WHALE?	COMMENTS
<i>Turret Cape</i>	Steel	1827	2079	253	1895	1959	64					X		Yes	No	Turret. On Lakes 1904-1941; 1950-59. Scrapped 1959.
<i>Turret Chief</i>	Steel	1881	1881	253	1896	1928	32					X		Yes	No	
<i>Turret Court</i>	Steel	1849	1849	253	1896	1931	35					X		Yes	No	
<i>Turret Crown</i>	Steel	1827	1827	253	1895	1924	29			X				No	No	Turret. To Lakes 1904. Wrecked 1924.
<i>John B. Trevor</i>	Steel	1713	2004	362	1895	1935	40					X		Yes	Yes	Off Lakes 1918. Scrapped 1935.
<i>George Farwell</i>	Wood	978	978	182	1895	1906	11			X				No	No	Off Lakes 1900. Wrecked Cape Henry 1906.
<i>George Stephenson</i>	Steel	4564	4564	407	1896	1959	63					X		Yes	No	Grain storage 1959. Scrapped 1963.
<i>Sir Henry Bessemer</i>	Steel	4321	4321	413	1896	1943	47					X		Yes	No	To storage barge 1943. Scrapped 1971.
<i>Coralia</i>	Steel	4331	4331	413	1896	1955	59					X		Yes	No	To grain storage 1955. Scrapped 1965.
<i>Sir William Siemens</i>	Steel	4344	4344	413	1896	1944	48				X			No	No	Collision, sank 1944.
<i>L. C. Waldo</i>	Steel	4244	4422	387	1896	1967	71					X		Yes	No	Scrapped 1967.
<i>Maricopa</i>	Steel	4224	4281	406	1896	1974	78					X		Yes	No	Sold for scrap 1974.
<i>Sir William Fairbairn</i>	Steel	4220	4220	424	1896	1962	66					X		Yes	No	Sold for scrap 1962.
<i>Robert Fulton</i>	Steel	4220	4220	424	1896	1946	50					X		Yes	No	Sold for scrap 1946.
<i>James Watt</i>	Steel	4090	4090	405	1896	1961	65					X		Yes	No	Sold for scrap 1961.
<i>Senator</i>	Steel	4049	4049	410	1896	1929	33				X			No	No	Collision, sank, vicinity Port Washington.
<i>Queen City</i>	Steel	3980	3980	401	1896	1947	51					X		Yes	No	Scrapped 1947.
<i>Lagonda</i>	Steel	3647	3647	375	1896	1958	62					X		Yes	No	Sold for scrap 1958.

NAME	CONSTRUCTION	TON (BUILT)	TON (FINAL)	LENGTH	LAUNCHED	END	TOTAL YEARS	BURN	SANK	WRECK	COLLISSION	SCRAPPED	OTHER	NATURAL?	WHALE?	COMMENTS
<i>City of Bangor</i>	Steel	3691	4202	372	1896	1926	30			X				No	No	Wrecked Keweenaw Point.
<i>E. W. Oglebay</i>	Steel	3666	3666	375	1896	1927	31			X				No	No	Wrecked vicinity Marquette, MI.
<i>John Ericson</i>	Steel	3201	3650	390	1896	1966	70					X		Yes	Yes	Out of service 1966, scrapped 1967.
<i>Frank Rockefeller</i>	Steel	2760	3383	366	1896	1972	76					X		Yes	Yes	Out of service 1972; museum.
<i>Appomatox</i>	Wood	2644	2644	319	1896	1905	9			X				No	No	Wrecked vicinity Milwaukee.
<i>Rosemount</i>	Steel	1580	1580	245	1896	1931	35					X		Yes	No	Out of service 1931. Scrapped 1939.
<i>Crescent City</i>	Steel	4213	4213	406	1897	1955	58					X		Yes	No	To grain storage 1955. Scrapped 1959.
<i>Empire City</i>	Steel	4118	4716	405	1897	1968	71					X		Yes	No	Scrapped 1968.
<i>Andrew Carnegie</i>	Steel	4100	4100	403	1897	1947	50					X		Yes	No	Scrapped 1947.
<i>Venezuela</i>	Wood	2125	2125	263	1897	1922	25					X		Yes	No	To barge 1922. Abandoned 1929.
<i>Niagara</i>	Steel	1951	1760	266	1897	1982	85					X		Yes	No	Out of service 1982.
<i>Black Rock</i>	Wood	1646	1646	237	1897	1925	28					X		Yes	No	Off Lakes 1912. Abandoned 1925.
<i>Bermuda</i>	Wood	1312	1246	220	1897	1924	27	X						No	No	Burned, Lake Ontario.
<i>Douglass Houghton</i>	Steel	5332	5107	456	1899	1969	70					X		Yes	No	Sunk for breakwater 1969
<i>Samuel F. B. Morse</i>	Steel	4936	4557	456	1898	1954	56					X		Yes	No	To barge 1954.
<i>Superior City</i>	Steel	4795	4795	429	1898	1920	22				X			No	No	Collision, sank, Whitefish Bay.
<i>Presque Isle</i>	Steel	4578	4538	407	1898	1996	98					X		Yes	No	To storage 1996. Scrapped 2008.

NAME	CONSTRUCTION	TON (BUILT)	TON (FINAL)	LENGTH	LAUNCHED	END	TOTAL YEARS	BURN	SANK	WRECK	COLLISSION	SCRAPPED	OTHER	NATURAL?	WHALE?	COMMENTS
<i>Clarence A. Black</i>	Steel	4521	4521	413	1898	1947	49					X		Yes	No	Scrapped 1947.
<i>Hendrick S. Holden</i>	Steel	4444	4488	408	1898	1965	67					X		Yes	No	Sold for scrap 1965, scrapped 1966.
<i>William R. Linn</i>	Steel	4328	4068	400	1898	1964	66					X		Yes	No	Sold for scrap 1964.
<i>Alexander McDougall</i>	Steel	3686	3686	413	1898	1947	49					X		Yes	Yes	Scrapped 1947.
<i>Amazonas</i>	Wood	2228	2228	295	1898	1930	32					X		Yes	No	Abandoned 1930.
<i>Orinoco</i>	Wood	2226	2226	295	1898	1924	26		X					No	No	Sank, Lake Superior.
<i>Cornell</i>	Steel	5082	5082	454	1900	1961	61					X		Yes	No	Sold for scrap 1961.
<i>Harvard</i>	Steel	5054	5054	461	1900	1960	60					X		Yes	No	Sold for scrap 1960.
<i>Lafayette</i>	Steel	5113	5113	454	1899	1905	6			X				No	No	Wrecked, vicinity Two Harbors, MN.
<i>Princeton</i>	Steel	5125	5125	454	1900	1953	53					X		Yes	No	To barge 1953.
<i>Rensselaer</i>	Steel	5124	5124	454	1900	1947	47					X		Yes	No	Scrapped 1947.
<i>Texas</i>	Steel	5229	5229	454	1899	1963	64					X		Yes	No	Sold for scrap 1963.
<i>Henry W. Oliver</i>	Steel	4909	4959	444	1899	1967	68					X		Yes	No	Scrapped 1967.
<i>Pennsylvania</i>	Steel	4840	4840	429	1899	1964	65					X		Yes	No	Sold for scrap 1964.
<i>Tennessee</i>	Steel	4951	4951	430	1899	1971	72					X		Yes	No	Sold for scrap 1971.
<i>H. C. Frick</i>	Steel	4713	4713	416	1899	1967	68					X		Yes	No	Laid up 1967. Scrapped 1970.
<i>William E. Reis</i>	Steel	4748	4611	416	1899	1967	68					X		Yes	No	Sold for scrap 1967.
<i>M. A. Hanna</i>	Steel	4661	4599	410	1899	1967	68					X		Yes	No	Sold for scrap 1967.
<i>Admiral</i>	Steel	4651	4651	423	1899	1923	24				X			No	No	Collision, sank, Lake Huron.

NAME	CONSTRUCTION	TON (BUILT)	TON (FINAL)	LENGTH	LAUNCHED	END	TOTAL YEARS	BURN	SANK	WRECK	COLLISSION	SCRAPPED	OTHER	NATURAL?	WHALE?	COMMENTS
<i>Angeline</i>	Steel	4644	4644	423	1899	1958	59					X		Yes	No	Grain storage 1958. Scrapped 1965.
<i>Aurania</i>	Steel	3113	3218	352	1895	1909	14		X					No	No	Engines fitted 1899. Sank 1909, Whitefish Bay.
<i>Eureka</i>	Steel	2122	2122	237	1899	1937	38					X		Yes	No	Off Lakes 1904. Scrapped 1937.
<i>Tampico</i>	Steel	2133	2133	247	1900	1963	63					X		Yes	No	Off Lakes 1904-20, '42-43. Barge 1963.
<i>India</i>	Wood - C	976	976	215	1899	1928	29	X						No	No	Burned, Georgian Bay.
<i>William Edenborn</i>	Steel	5910	5910	478	1900	1962	62					X		Yes	No	Sold for breakwater, 1962.
<i>Isaac L. Ellwood</i>	Steel	5904	5904	478	1900	1961	61					X		Yes	No	Scrapped 1961.
<i>John W. Gates</i>	Steel	5946	5946	478	1900	1961	61					X		Yes	No	Scrapped 1961.
<i>James J Hill</i>	Steel	6025	6025	478	1900	1962	62					X		Yes	No	Sold for breakwater, 1962.
<i>General Orlando M Poe</i>	Steel	5619	5619	470	1900	1954	54					X		Yes	No	Reduced to barge 1954, scrapped 1956.
<i>Robert W. E. Bunsen</i>	Steel	5181	5181	439	1900	1954	54					X		Yes	No	Converted to barge 1954. Apparently still in service.
<i>Charles R. Van Hise</i>	Steel	5117	6922	458	1900	1968	68					X		Yes	No	Sold for scrap, 1968.
<i>Captain Thomas Wilson</i>	Steel	4719	4719	420	1900	1946	46					X		Yes	No	Scrapped 1946
<i>Simon J. Murphy</i>	Steel	4869	4869	435	1900	1960	60					X		Yes	No	Sold for scrap 1960.

NAME	CONSTRUCTION	TON (BUILT)	TON (FINAL)	LENGTH	LAUNCHED	END	TOTAL YEARS	BURN	SANK	WRECK	COLLISSION	SCRAPPED	OTHER	NATURAL?	WHALE?	COMMENTS
<i>Howard L. Shaw</i>	Steel	4901	4901	435	1900	1969	69					X		Yes	No	Sunk as breakwater.
<i>Asuncion</i>	Steel	2196	2196	242	1900	1924	24					X		Yes	No	Scrapped 1924.
<i>Paraguay</i>	Steel	2201	2627	242	1900	1927	27			X				No	No	Off Lakes 1902. Sank 1927.
<i>William P. Palmer</i>	Steel	2293	2293	242	1900	1936	36			X				No	No	Wrecked 1936, Fairport, OH.
<i>A. B. Wolvin</i>	Steel	2286	2286	242	1900	1916	16		X					No	No	Off Lakes 1911. Presumed sunk 1916.
<i>Ravenscraig</i>	Steel	2280	2280	243	1900	1923	23					X		Yes	No	Presumed scrapped 1923.
<i>Donnacona</i>	Steel	1906	1906	245	1900	1915	15		X					No	No	Off Lakes 1915; sank same year.
<i>Strathcona</i>	Steel	1881	1881	249	1900	1917	17						X	War	No	Off Lakes 1915. Sunk enemy action 1917.
<i>Alfred Mitchell</i>	Wood	1751	1751	255	1900	1921	21					X		Yes	No	Off Lakes 1917. Presumed scrapped 1921.
<i>Cartagena</i>	Wood	1532	1532	241	1900	1907	7			X				No	No	Off Lakes 1907; wrecked same year.
<i>Georgetown</i>	Steel	1358	1358	243	1900	1917	17		X					No	No	Off Lakes 1916. Sank 1917.
<i>Waccamaw</i>	Steel	1359	1471	249	1900	1931	31					X		Yes	No	Laid up 1931.
<i>Neptune</i>	Steel	3717	3493	346	1900	1966	66					X		Yes	No	Laid up 1966.
<i>Australia</i>	Steel	3745	3845	376	1898	1948	50					X		Yes	No	Engines fitted 1902. Scrapped 1948.
<i>Amazon</i>	Steel	3702	3702	376	1897	1954	57					X		Yes	No	Engines fitted 1908. Scrapped 1954.
<i>W. H. Gilbert</i>	Steel	2820	2820	328	1892	1914	22				X			No	No	Collision sank.
<i>Globe</i>	Steel	2996	3865	330	1894	1963	69					X		Yes	No	Sold for scrap 1963.

NAME	CONSTRUCTION	TON (BUILT)	TON (FINAL)	LENGTH	LAUNCHED	END	TOTAL YEARS	BURN	SANK	WRECK	COLLISSION	SCRAPPED	OTHER	NATURAL?	WHALE?	COMMENTS
<i>Charles W. Wetmore</i>	Steel	1399	1399	265	1891	1892	1			X				No	Yes	Off Lakes 1891, wrecked 1892, Coos Bay, OR.
<i>Thomas Wilson</i>	Steel	1713	1713	308	1892	1902	10				X			No	Yes	Collision, sank.
<i>Washburn</i>	Steel	2234	2234	320	1892	1936	44					X		Yes	Yes	Scrapped, 1936.
<i>Pillsbury</i>	Steel	2234	2234	320	1892	1934	42			X				No	Yes	Stranded, total loss.
<i>Barge 101</i>	Steel	428	428	178	1888	1908	20		X					No	Yes	Sank, Maine coast.
<i>Barge 102</i>	Steel	1192	1192	253	1889	1905	16		X					No	Yes	Foundered Cape Charles, VA.
<i>Barge 103</i>	Steel	1192	1192	253	1889	1909	20		X					No	Yes	Foundered, Sandy Hook, NJ.
<i>Barge 104</i>	Steel	1295	1295	276	1890	1908	18		X					No	Yes	Foundered, vicinity Cleveland, OH.
<i>Barge 105</i>	Steel	1295	1295	276	1890	1910	20		X					No	Yes	Foundered, vicinity Fire Island Lightship, NY.
<i>Barge 107</i>	Steel	1295	1295	276	1890	1913	23		X					No	Yes	Sank Nantucket Shoals, 1913.
<i>Barge 109</i>	Steel	1227	1227	265	1891	1914	23		X					No	Yes	Foundered Montauk Point, NY.
<i>Barge 110</i>	Steel	1296	1296	265	1891	1932	41	X						No	Yes	Explosion, burned at dock, sank, St Rose, LA.
<i>Barge 111</i>	Steel	1227	1227	265	1891	1916	25				X			No	Yes	Collision, sank, Hampton Roads, VA.
<i>Barge 115</i>	Steel	1169	1169	256	1891	1899	8			X				No	Yes	Stranded, Pic Island, Lake Superior
<i>Barge 116</i>	Steel	1169	1176	256	1891	1946	55					X		Yes	Yes	Scrapped, TX, 1946.
<i>Barge 117</i>	Steel	1310	1159	285	1891	1926	35						X	Unknown	Yes	Sold British 1926, no further record.
<i>Barge 118</i>	Steel	1310	1159	285	1891	1946	55					X		Yes	Yes	Scrapped, TX, 1946.

NAME	CONSTRUCTION	TON (BUILT)	TON (FINAL)	LENGTH	LAUNCHED	END	TOTAL YEARS	BURN	SANK	WRECK	COLLISSION	SCRAPPED	OTHER	NATURAL?	WHALE?	COMMENTS
<i>Barge 122 (Sagamore)</i>	Steel	1601	1601	308	1892	1901	9				X			No	Yes	Collision, sank, Whitefish Bay.
<i>Barge 126</i>	Steel	1128	1128	264	1892	1905	13			X				No	Yes	Stranded, Buzzard's Bay, MA.
<i>Barge 127</i>	Steel	1128	1148	264	1892	1936	44					X		Yes	Yes	Scrapped 1936, New Orleans, LA
<i>Barge 129</i>	Steel	1310	1310	292	1893	1902	9				X			No	Yes	Collision, sank, 1902.
<i>Barge 130</i>	Steel	1310	1310	292	1893	1924	31					X		Yes	Yes	Scrapped, TX, 1924.
<i>Barge 131</i>	Steel	1310	1159	292	1893	1946	53					X		Yes	Yes	Scrapped, TX, 1946.
<i>Barge 132</i>	Steel	1310	1159	292	1893	1927	34		X					No	Yes	Foundered, Freeport, TX
<i>Barge 133</i>	Steel	1310	1159	292	1893	1911	18		X					No	Yes	Foundered, Fire Island, NY.
<i>Barge 134</i>	Steel	1310	1159	292	1893	1912	19			X				No	Yes	Stranded, Hampton Roads, VA.
<i>Barge 137</i>	Steel	2480	2638	345	1896	1965	69					X		Yes	Yes	Scrapped, 1965
<i>Barge 201</i>	Steel	664	948	182	1890	1919	29			X				No	Yes	Stranded, Sandy Hook, NJ.
<i>Barge 202</i>	Steel	665	948	182	1890	1908	18		X					No	Yes	Foundered, Barnegat, NJ.