

David V. Beard. H.M.S. *DEBRAAK*: A TREASURE DEBUNKED, A TREASURE REVEALED. (Under the direction of Dr. William N. Still, Jr.) Department of History, July 1989.

The purpose of this study is to document the history, salvage and architecture of the brig-of-war H.M.S. *DeBraak*. Since the day that she sank in a sudden squall off the coast of Delaware on May 25, 1798 a legend of an immense treasure filling her holds has been widely circulated. As could have been expected, such a legend would attract those who would have this treasure for their own. Between 1984 and 1986 a Reno, Nevada-based commercial salvage firm, Sub-Sal, Inc., excavated the vessel's wreck site. These operations climaxed on August 11, 1986 with the raising of *DeBraak's* articulated hull remains, and the subsequent clamshelling of the site to recover artifacts.

No substantial treasure was recovered from the ship, but the project did generate a considerable amount of outrage among the archeological community due to the damage sustained by *DeBraak's* hull and many of its associated artifacts. This outrage may have directly encouraged the passage of the Abandoned Shipwrecks Act of 1988, which in previous years had failed to pass in the United States Congress.

The author was employed by the state of Delaware from 1985 through 1988. His responsibilities included monitoring the salvage operations, mapping the wreck site, artifact processing, researching the ship's history, and, finally, documenting the architecture of *DeBraak's* hull remains.

H.M.S. *DEBRAAK*: A TREASURE DEBUNKED,
A TREASURE REVEALED

A thesis
Presented to
the Faculty of the Department of History
East Carolina University

In Partial Fulfillment
of the Requirements of the Degree
Master of Arts in History

by
David V. Beard
July 1989

ACKNOWLEDGEMENTS

I would like to thank Dr. William N. Still, Jr., of the Department of History at East Carolina University for his direction of this thesis. Thanks also go to the other members of my committee, Professor Gordon P. Watts, Jr., Dr. John Tilley and Dr. Richard Stephenson for valuable observations and suggestions and for helping to expedite the process.

Special thanks go to various personnel of the Delaware Division of Historical and Cultural Affairs for their assistance with this project. Charles Fithian, Curator of Archaeology deserves particular credit for overall organization of *DeBraak* Project data. Thanks also go to Walt Lennington for producing several of the illustrations in this report.

I would also like to thank my family for their support and encouragement throughout my academic career.

And finally, this thesis is dedicated to the late Katherine J. (Kackie) Hardie, Professor of Anthropology at the University of Arkansas at Little Rock, without whose encouragement and guidance at a pivotal point in my life this thesis would not have been possible. Like many of Kackie's students I will "keep on keepin' on" as a tribute to her memory.

TABLE OF CONTENTS

	Page
LIST OF FIGURES.....	vi
INTRODUCTION.....	x
Chapter	
I. VESSEL HISTORY.....	1
II. THE SEARCH FOR <i>DEBRAAK</i>	33
III. THE SALVAGE OF <i>DEBRAAK</i>	41
IV. SITE LOCATION AND DESCRIPTION.....	61
V. METHODOLOGY FOR SITE AND HULL DOCUMENTATION.....	71
A. Underwater.....	71
B. Post-recovery.....	74
VI. ARCHITECTURAL ANALYSIS.....	80
A. Historical Perspective.....	80
B. The 1797 Refitting.....	82
C. Hull Construction Description and Analysis.....	91
Keel.....	93

Chapter
VI (cont)

	Page
False Keel.....	96
Hog.....	97
Stem Construction.....	99
Stern Construction.....	102
Framing.....	105
Keelson.....	111
Hull Planking.....	116
Ceiling Planking.....	116
Riders and Knees.....	120
Breast Hooks.....	121
Mast Steps.....	121
Riding Bitt and Bowsprit Step Posts (Pillars).....	128
Limber Boards.....	131
Bulkheads and Partitioning.....	136
Hold Platform.....	140
Shot Lockers.....	140
Firehearth Pit Liner.....	146
Bilge Pumps and Scuppers.....	149
Capstan.....	153

Chapter	Page
VI (cont)	
Rudder and Associated Fittings.....	154
Fasteners.....	162
Hull Alterations and Repairs.....	164
Copper Sheathing.....	170
D. Current Status.....	173
VII. SUMMARY AND CONCLUSIONS.....	178
APPENDIX A: Crew Analysis, H.M.S. <i>DeBraak</i>	182
APPENDIX B: 1986 Lease and Methodology.....	188
APPENDIX C: Drift Pin Data.....	194
APPENDIX D: Glossary of Ship Terms.....	203
BIBLIOGRAPHY.....	209

LIST OF FIGURES

Figure	Page
1 <i>DeBraak</i> "As When Taken" Sheer Plan.....	7
2 <i>DeBraak</i> "As Fitted" Sheer Plan.....	8
3 Side-Scan Sonograms of <i>DeBraak</i> Wrecksite.....	38
4 1984 Site Map.....	43
5 1985 Site Map.....	46
6 Site Location.....	62
7 Simplified Site Stratigraphy.....	64
8 1986 Site Map (Revised).....	66
9 Simplified Site Formation Process.....	67
10 Overhead Photograph of <i>DeBraak</i> 's Hull.....	79
11 <i>DeBraak</i> "As When Taken" Sheer Plan.....	83
12 <i>DeBraak</i> "As Fitted" Sheer Plan.....	84
13 <i>DeBraak</i> "As Fitted" Deck Plan.....	85
14 H.M.S. <i>Raven</i>	87
15 Simplified Representation of Surviving Hull Fabric.....	92
16 Profile of <i>DeBraak</i> 's Backbone Timbers.....	94
17 Keel Scarphs.....	95
18 Unusual Wedge Shaped Deadwoods.....	98
19 Stem Construction.....	100
20 Cross-Section Through Apron/Hog Scarph.....	101
21 Stern Construction.....	103
22 Cross-Sections of Stern Deadwoods.....	104

Figure	Page
23 Example of <i>DeBraak's</i> Framing at Keel.....	106
24 Extremes of Molded Floor Dimensions.....	108
a. Last Square Floor.....	108
b. Mid-Ship Floor.....	108
25 Limber Holes.....	109
a. One Common Method.....	109
b. <i>DeBraak's</i> Limber Holes.....	109
26 Examples of Futtock Butting (a) and Chocking (b).....	110
27 Keelson Scarphs.....	112
28 Plan-View of Keelson and Ceiling Planking Expansion.....	113
29 Cheek Fastener Pattern.....	114
30 Thickstuff.....	117
31 Bulwark Fragment.....	118
a. With Concreted Solid Shot <i>In-Situ</i>	118
b. With Concreted Solid SHot Removed.....	118
c. Profile.....	118
32 Iron Breasthook (?).....	122
33 Cross-Section and Plan View at Cutter Mast Step.....	123
34 Cross-Section and Plan View of <i>Defense</i> Mainmast Step.....	124
35 Cross-Section and Plan View at Mainmast Step.....	125
36 Cross-Section and Plan View at Foremast Step.....	126
37 Riding Bitt Post Step (a) and Post in Place (b).....	129
38 Bowsprit Step Post in Place(a) and Step (b).....	130

Figure	Page
39 Limber Strakes.....	132
a. <i>DeBraak's</i> Limber Board Retainer Strake.....	132
b. Rabbeted Limber Strake.....	132
40 Plan View of Keelson and Starboard Side Limber Boards.....	133
41 Cross-Sections Through Starboard Side Limber Boards.....	134
42 Example of Port Side Limber Boards.....	135
43 Simplified Site Plan Showing Lost Timbers.....	137
44 Reconstructed Forward Athwartship Bulkhead Section.....	138
45 Hold Stringers.....	139
46 Cross-Section of Reconstructed Hold Platform.....	141
47 Plan View of Shot Lockers.....	142
a. <i>DeBraak</i>	142
b. <i>Defense</i>	142
48 Profile of <i>DeBraak</i> Shot Lockers.....	143
49 Athwartship Sections of <i>DeBraak</i> Shot Lockers.....	144
50 Profile and Athwartship Sections of Defense Shot Lockers.....	145
51 Lead Firehearth Pit Liner.....	147
52 Base of Port Side Bilge Pump Tube.....	150
53 Scuppers.....	151
a. <i>DeBraak</i> (1797).....	151
b. <i>Dartmouth</i> (1655).....	151
54 Possible Attachment for <i>DeBraak</i> Scuppers.....	152
55 Rudder Reconstruction.....	155

Figure	Page
56 Rudder Fittings.....	156
a. Pintle.....	156
b. Gudgeon.....	156
c. Spectacle Plate.....	156
57 Pintle Data.....	157
58 Gudgeon Data.....	158
59 Chains on Rudder and Transom.....	159
60 Copper and Iron Bolts.....	162
61 Copper Spikes and Nails.....	163
62 Dryrotted and Replaced Frames in Stern.....	165
63 Patched and Dryrotted Ceiling Plank.....	166
64 Repaired Keel at Sternpost.....	168
65 Copper Sheathing on a 32-Gun Frigate.....	171
66 Examples of <i>DeBraak</i> Sheathing.....	172
a. Hull.....	172
b. Keel.....	172
c. Stamp in Sheathing.....	172

INTRODUCTION

When H.M.S. *DeBraak*, sixteen guns, Captain James Drew commanding, capsized and sank in a storm off the Delaware coast in May of 1798, the ship had had as checkered a career as any vessel in the Royal Navy. Built in England as a cutter, probably in the late 1770's, *DeBraak* (not her original name) had been captured by the French during the American Revolution and sold to the Dutch in 1781. While in Falmouth Harbor, England in March of 1795, the ship was seized after war broke out between Great Britain and the Revolutionary French government's ally, the Dutch Batavian Republic. Taken into the Royal Navy, *DeBraak* was converted into a brig and underwent extensive refitting before being officially commissioned in June of 1797.

Assigned to a convoy bound for North American ports in early spring of 1798, *DeBraak* became separated from the rest of the fleet during bad weather in early April. That is where the historical documentation of the vessel's movements ceased until she appeared off Cape Henlopen, Delaware on May 25 with a Spanish merchant ship as a prize. A sudden and intense squall out of the northwest blew *DeBraak* over on her beam ends, causing her to sink rapidly. Captain Drew, thirty-eight crew members, and twelve Spanish prisoners were drowned. Drew's body washed ashore and was buried in a cemetery in Lewes, Delaware.

DeBraak's surviving crew members began to circulate tales of Spanish treasure around the little port of Lewis Town. These tales were most likely the products of ample intoxicating spirits and the company of willing female listeners in this town then known for its brothels. The stories

were probably reinforced by the sailors spending Spanish gold and silver coins taken from the hapless crew of their prize. As drunken sailors have been known to do, they blew their exploits at sea out of proportion and a few bags of gold and silver coins became overflowing chests of treasure.

During August of 1798 the British made a feckless attempt to lift *DeBraak*. Had there been a substantial treasure on board her, there can be little doubt, a more intensive effort would have been made to recover it. The technology for such a salvage operation was in wide use at the time.

The wreck was soon forgotten by the British, who were embroiled in the Napoleonic Wars with France and her allies. But the citizens of coastal Delaware did not forget the tales of a fabulous treasure waiting just off-shore for anyone who could find it.

During the next 186 years no fewer than ten major expeditions were mounted to search for *DeBraak* and her legendary treasure. It was not until the spring of 1984 that a Reno, Nevada, based salvage firm, Sub-Sal Inc., positively identified the location of the wreck. Armed with a federal court ruling awarding the company salvage rights, Sub-Sal negotiated a lease of state bottom lands through the Delaware Department of Natural Resources and Environmental Control. For the next three years the salvors excavated the site, first using reasonable archeological methodology. After a change in management in the salvage company a new agreement was negotiated with the state of Delaware in which the hull of *DeBraak* would be lifted from the ocean floor and the site excavated with a clamshell bucket in an effort to recover the "treasure" more efficiently. Under the terms of the lease the state would receive twenty-five percent of any net profits from the salvage operations.

On August 11, 1986, *DeBraak* was lifted from the ocean floor in an operation that caused all of the wreck's artifact-bearing matrix to be dumped out. This material was later recovered via a fifteen-cubic-yard clamshell bucket and sifted through a gravel sorter. The hull remains were severely damaged when the lifting cables cut through the water-logged wood.

There has been no net profit, only an almost three million dollar expenditure. Approximately one-tenth of this has been spent by the state of Delaware for off-shore observation, site mapping, cataloging and stabilization of the artifact collection, maintenance of the artifact storage facility and hull, and contracts with researchers who had been retained to gather as much information as possible about *DeBraak*.

The following study is part of that ongoing research. It includes as much of the vessel's history as is available. It seeks to answer questions about the ship's exact origin, which is still unclear. Also included are brief accounts of the major salvage attempts and a critical appraisal of the way the state of Delaware has handled its involvement with these operations. Finally, there are the results of a detailed study of *DeBraak's* hull remains, which shed some light not only on the origin of the ship, but also on the state of the shipwright's art during the last quarter of the eighteenth century, when wooden warship construction had almost reached its zenith and the age of the iron ship loomed in the not-too-distant future.

The legendary treasure of *DeBraak* was not silver and gold, but the wealth of archeological and architectural data that was sealed within her wreck site. The salvage of the ship has led to the expenditure of millions of dollars in lost investments over the years and in 1986 one of the worst

maritime archeological disasters in recent history. The loss of irreplaceable archeological data and the needless damage sustained by *DeBraak's* hull and many of its associated artifacts cannot be condemned too strenuously. But *DeBraak* was not the problem, it was merely a symptom of a larger problem - the failure of the United States to enact legislation before 1988 aimed at protecting the single most threatened archeological resource in this country: historic shipwrecks. It was under those conditions that the state of Delaware was forced into an agreement allowing the commercial salvage of *DeBraak*.

With that in mind, the author of this study and the other researchers involved with the *DeBraak* project feel that our efforts should stand on their own merits, without the stigma of the salvage operations attached to them.

CHAPTER I

VESSEL HISTORY

Captain James Drew may have fidgeted as his servant tried to tie on his scarf. He had reason to be nervous. His ship, the sixteen-gun brig H.M.S. *DeBraak*, had in company with her a recently captured Spanish merchantman, the *Don Francisco Xavier*, and he knew that French privateers were operating along the North American coast.¹ The date was May 25, 1798 and with the war in Europe and America's Quasi-War with France in progress, the sea was a dangerous place.

Drew was equally worried about catching up with the convoy from which his ship had become separated in early April. He knew that parts of the convoy had already reached the ports from Georgia to the Chesapeake Bay and that *DeBraak* could not be more than a day or two behind. As much as he would have liked to keep moving, his ship needed to take on fresh water. The two month trans-Atlantic voyage had left supplies of drinking water foul and covered with green scum. For this purpose he had brought his ship off Cape Henlopen at the mouth of the Delaware Bay where the water casks could be taken into the port of Lewistown, Delaware to be filled.

A boat had been lowered alongside to take Drew and the landing party ashore with the casks. The captain had been keeping a close eye on a storm that was moving down from the northwest, but he was confident that after a rough trans-Atlantic crossing his ship could weather almost anything. As a precaution he had the ship under short sail.²

With very little warning, the storm increased in intensity and *DeBraak* was blown over on her beam ends, sinking almost immediately. Drew and about half of his crew perished. The survivors went on board the prize and took her to an anchorage in the safety of Lewistown harbor. As they relaxed over warming spirits with the locals, the weary seamen began to relate their experiences and close brush with death. Out of these tales would arise a word which would alter the vessel's place in history forever. That word was "treasure."

The story of H.M.S. *DeBraak* is a fascinating one, especially if one takes into consideration that much of what is "known" about the ship and her history is patently false. It is one of those ironies of history that made the most significant act of this vessel her sinking. After that point, the story of the ship's last voyage took on a life of its own. Time, rumor, lust, and greed, combined to transform this lowly Royal Navy brig into one of the greatest treasure ships in the world. Documentary fact and logic aside, it was these tales of fabulous treasure that clouded the true story for almost two hundred years.

The early history of *DeBraak* is almost as shrouded in mystery as the period during which she was separated from her convoy. Conflicting information from Dutch archival sources make separating truth from fiction even more difficult. Two inquiries by different researchers, one in 1964 and another in 1973, yielded different results about the origin of *DeBraak*. The 1964 inquiry yielded information which indicated that the ship had been purchased by the Dutch for the Admiralty of the Maas (Rotterdam) in 1781.³ The response to the 1973 inquiry stated that the vessel had been built for

the Admiralty of the Maas.⁴ Recently acquired information seems to indicate that the former is true.

On the basis of a deposition given by the Dutch captain shortly after the ship was captured by the British in 1795, it seems that *DeBraak* was purchased from the French in 1781. According to the Dutch captain the French had captured the ship from the British during their "last war," which would have been the Anglo-French war corresponding with the final years of the American Revolution. The French renamed the ship *Le Patrocle*.⁵

Since there is no mention in the British Admiralty records indicating that the British had recaptured one of their lost vessels, it may be that *DeBraak* was not originally a Royal Navy vessel, but instead a privateer built for preying on the enemies of the Crown for profit.⁶

After being taken into the Dutch service, *deBrak* (the Dutch spelling) was put under the command of Captain Alexander Gijsbert de Viroux. On August 10, 1784 the vessel sailed out of Texel Roads for a rendezvous at Malaga, Spain, with a squadron under the command of Rear Admiral Jan Hendrik van Kinsbergen. Information as to the further movements of this squadron has not been located. When Captain de Viroux was ordered to take command of the thirty-six-gun frigate *Jason, deBrak* was put under the command of Cornelis de jong. On December 6, 1784 *deBrak* was at Toulon, France, where she joined a squadron under the command of Captain Pieter Melvill. This squadron returned to the Netherlands in December, 1787 after some three years of sea duty.⁷ The squadron may have been convoying the Dutch East India Company trade or escorting Dutch merchant shipping in the Mediterranean Sea, where pirates were a constant menace.

The next known movements of *deBrak* didn't take place until 1793. In March of that year, *deBrak*, then under the command of a Lieutenant Grotenray, was one of three ships used in the defence of the fortress-city of Wilemstad, which was under attack by an invading French army.⁸

Revolutionary France had declared war on Engalnd and Holland on February 1, 1793 and French forces under General Dumouriez invaded Holland on February 16. It took a combined Dutch and English force to rout the French at the Roer River on March 1, forcing Dumouriez to withdraw from Holland.⁹

After her service at Willemsstad, *deBrak* sailed out of the Maas River on December 19, 1794 to join a convoy bound for Surinam, at that time a Dutch colony. *DeBrak's* commander was Captain John Arnold van Grootenray. This name may well be another spelling of Grotenray, a common error in eighteenth century writing, and the lieutenant may have been made captain for his performance at Willemsstad. Upon reaching the North Sea, *deBrak* joined a squadron under the command of Captain Gerard Corthuys aboard the frigate *Medemblik*. This squadron was to convoy a number of merchant vessels to the East Indies.¹⁰ No explanation is given in the Dutch references indicating why *deBrak's* destination was changed from the West Indies to the East Indies.

While this squadron was at sea big changes were taking place back in the Netherlands. Due to French influence, revolutionary fever broke out in Holland early in 1795. William V, the Prince of Orange, was forced to flee Holland in January of that year and set up a government in exile in England.¹¹

Dutch records indicate that the squadron arrived at Plymouth, England on January 10, 1795 and was detained by British authorities on the twentieth, due to the fact that the revolutionary Dutch Batavian Republic had allied itself with France and was now at war with Britain. This conflicts with British Admiralty records, which state that on May 30, 1795 *deBrak* and a Dutch East India ship were detained in Falmouth Harbor by H.M.S. *Fortune*, sixteen guns, under the command of a Commander Wooldridge.¹² Records also indicate that five other Dutch men-of-war were detained in other British ports. These were: *Lealand*, sixty-six guns; *Brakel*, fifty-six guns; *Tholin*, thirty-six guns; *Pyl*, fourteen guns; and *Mierman*, sixteen guns.¹³

The officers and crew of *deBrak* were given a choice as to their fate. They could remain in England under the authority of the Prince of Orange, or they could be sent back to Holland as paroled prisoners of war. More than sixty of the officers and crew opted to be returned to Holland while only five remained in England.¹⁴

An English crew was put aboard *deBrak* and on June 27 she sailed for Plymouth in the company of *Fortune* and *Expedition*. *Debrak* and *Fortune* arrived there late in the day, having experienced some heavy weather, anchored and reported their arrival to the Admiralty. *Expedition* had apparently parted company along the way.¹⁵

While *deBrak* waited in Plymouth, the British negotiated with the Prince of Orange over the final disposition of the captured Dutch vessels. It can be assumed that the prince decided to allow the ships to be taken into the Royal Navy because on September 1, 1796 *deBrak* and the other five

Dutch men-of-war, all of which were then in Plymouth, were ordered to be surveyed, and recommendations of their service fitness drawn up.¹⁶

This survey concluded that the vessels were in servicable condition and most of them could be ready within six weeks. *DeBrak* would require only three weeks for refitting. This same report recommended that the Dutch cutter be converted into a brig.¹⁷ For this purpose, *deBrak* was ordered to the dockyard at Plymouth for refitting in May, 1797.

At Plymouth yard *DeBraak* (the English name of the ship) was taken into dry dock. There a survey of the ship was made and a set of plans was drawn up showing her hull and decks "as when taken" (Fig. 1).¹⁸ This done, the English shipwrights set about the task of converting the ship from a single-masted cutter to a two-masted brig. This conversion required a rearrangement of the decks and interior spaces and an alteration of the rake of the bowsprit, so it would be able to withstand the strain caused by the alteration of the headsails (Fig.2).¹⁹

The reasons for this conversion may be rooted in the conditions of the Royal Navy at that time. The cutter or "Bermuda rig" on a vessel of *DeBraak's* size was not popular with British naval officers. Although very maneuverable, this type of rig required a large crew just to work the sails. At a time when trained officers and seamen were at a premium and a state of war required that all active duty ships be prepared for combat, it was reasoned that as few men as possible should be involved in working the sails.²⁰

Finally, *DeBraak's* hull was sheathed in copper to protect it from the effects of boring marine worms endemic to the temperate and tropical

Hand
197
Whitehall

2/5/4

DE BRAAK - 1844

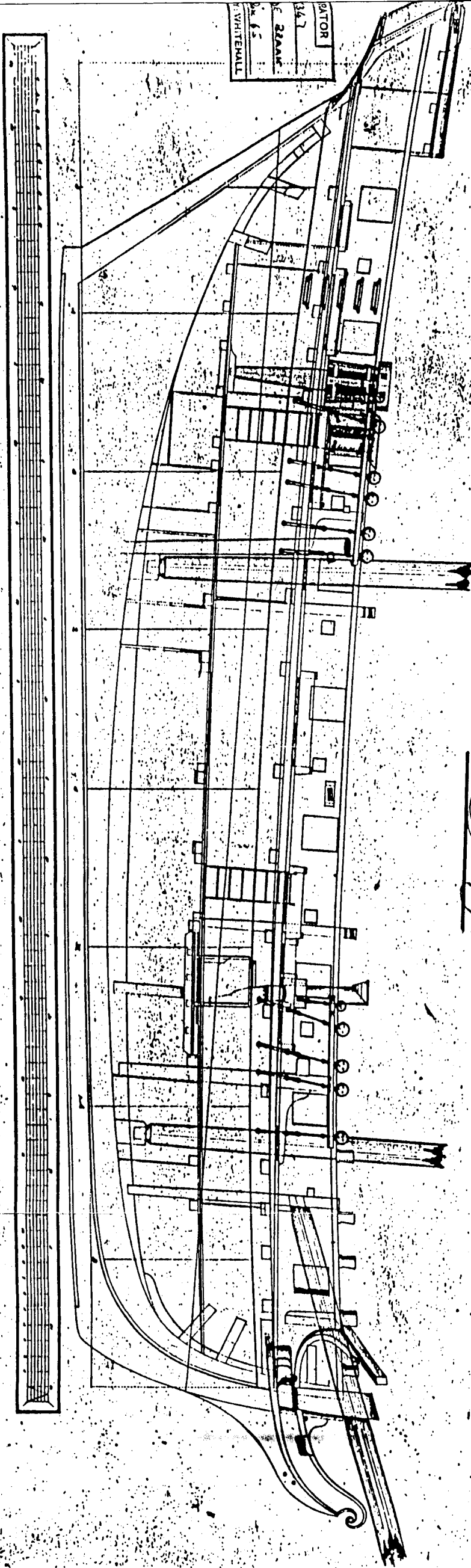

ATOR
222
WHITEHALL

PIRE 2

FIGURE 1

DATE
BY
DRAWN BY

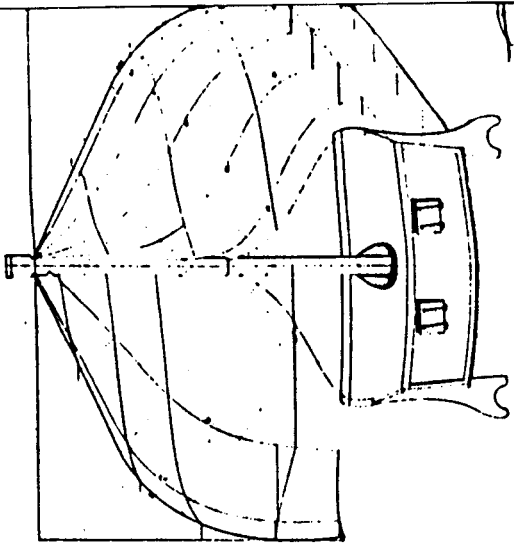

Scale
1/2"

1/2"

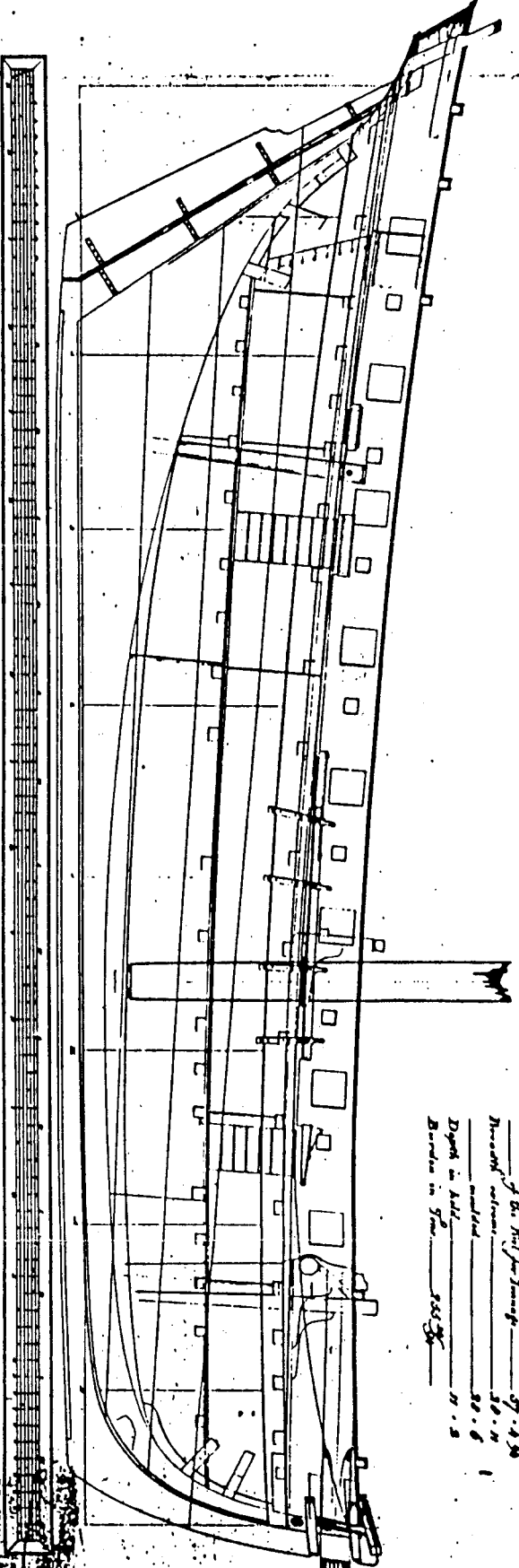
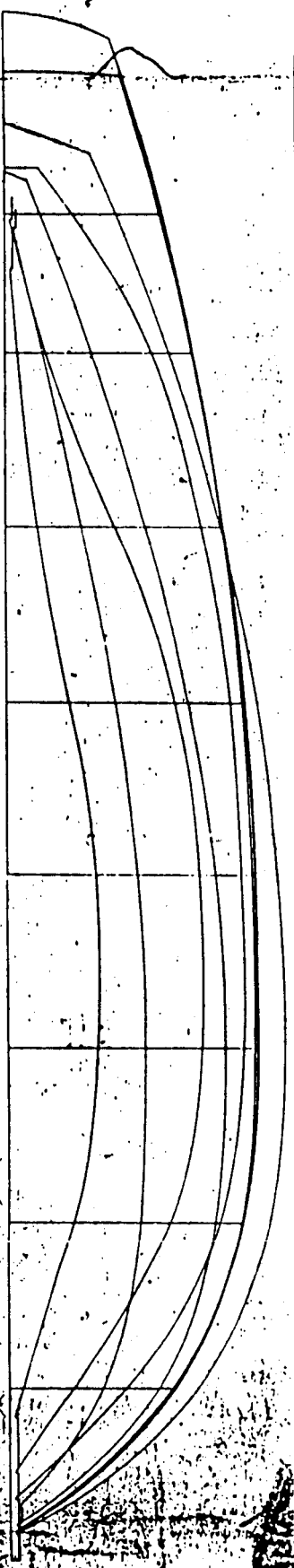

DE BRAN...
Length on the upper end ... 61.0
of the ... 57.4 M
Diameter ... 22.0
Depth in hull ... 11.5
Breadth in stem ... 3.0

waters in which the vessel would be operating. Not only did this sheathing protect the hull from worm damage, it discouraged the growth of barnacles and other marine life which greatly affected the efficiency of ships not having this protection.

By June *DeBraak* was ready for service, and she began wages on the thirteenth of that month. A ship begins wages when the assigned officers and crew are entered into her muster and pay books. During this time common seamen received no pay unless assigned to a ship, and many officers were put on half pay or no pay while not on active duty. Lieutenant James Drew was put in command of the ship and went aboard on June 16.²¹ *DeBraak* was given a complement of eighty-six officers and crew and provisioned for Channel service.²²

From *DeBraak's* muster books it appears that the vessel was then ordered to convoy duty around the British Isles. This is verified by a letter from Drew to Evan Nepean, Secretary of the Admiralty, on September 13, 1797 in which Drew reports having arrived at Milford Haven with "the trade" from Plymouth.²³ During this time Drew was beginning to notice defects in his ship. Upon the advice of the Navy Board, *DeBraak* was armed with a battery of sixteen 24-pounder carronades.²⁴ On July 16 Drew wrote to the Admiralty and requested that the Commissioners order two 6-pounders for bow chasers in lieu of two of the carronades.²⁵ This request was granted and the new guns were put on board.

Another problem that developed would take on an ominous air later in *DeBraak's* history. Drew wrote to the Admiralty on December 11, 1797 to report that *DeBraak* had sprung her mainmast and that he felt she was

over-masted.²⁶ Drew was ordered to take his ship to Plymouth for refitting and repair of the sprung mast on December 16.²⁷

It is not known whether or not *DeBraak's* masts were reduced, but research into the ship's rigging components has established that they are generally much larger than regulation for vessels of that size.²⁸ It is speculated that over-masting may have contributed to *DeBraak's* sinking. It is interesting to note that the Royal Navy lost a number of small brigs to capsizing during this period.²⁹ Could it be that these other lost vessels were also conversions, and that this attempt to economize on manpower ultimately resulted in needless loss of lives and ships?

Once the needed repairs had been made to *DeBraak*, Drew was ordered by the Admiralty to provision the ship for three months of Channel service. However, on February 8, 1798 his orders were changed and he was directed to provision for six months of foreign service.³⁰ Drew was ordered to sail for Cork as soon as he was ready and report to Vice Admiral Kingsmill under whose direction he was to "collect such Trade bound to North America," wait for the arrival of the sixty-four-gun ship H.M.S. *St. Albans*, under the command of Captain Francis Pender, and upon the arrival of that vessel "put himself and the Trade assembled" under Pender's command and protection.³¹

Drew wrote to the Admiralty on February 18 that due to illness he was unable to sail immediately. He also reported that he had on board "three of the most seditious and mutinous men in the King's service ... who may be capable of corrupting the minds of [*DeBraak's*] company." He requested that a lieutenant be appointed immediately to the ship so an officer would be on

be on board to keep these men under control.³² Drew's fears were not without some foundation.

The Royal Navy, and perhaps the entire British Empire, was still experiencing the effects of the "Great Mutiny" of the Nore in 1797. At that time it seemed that the entire navy was in rebellion and that the very life blood of the Empire was at stake. Although this mutiny would eventually be considered a catalyst for change in the way common seamen were treated at the hands of often sadistic officers, in 1798 it was still considered a threat to the status-quo and any discontent among a ship's crew caused a certain amount of paranoia among her officers.

DeBraak apparently had been without a lieutenant during much of her recent service. On June 26, 1797 Drew had requested that Lieutenant James Wall be appointed the ship's first lieutenant.³³ Later, on September 27, Drew reported that Lieutenant Percy Dove of *DeBraak* had been hospitalized and that he would not likely be fit for duty anytime soon. Therefore he requested that his nephew, Lieutenant John Drew of H.M.S. *Cerberus*, be appointed in Dove's place.³⁴

Lieutenant Drew apparently did not get this appointment and was on board *Cerberus* on January 11, 1798 in Cawsand Bay near Plymouth. On that day, a longboat from *Cerberus* capsized and his uncle Captain John Drew (James's brother), and his brother James William Drew were both drowned.³⁵ The melancholia caused by his brother's and nephew's recent deaths, combined with the generally unwholesome conditions at sea during this period, very likely combined to cause James Drew's ill health.

By early March Drew had returned to *DeBraak* and with ten merchant vessels in company she sailed out of Plymouth on the second. Because of what Drew described as "very thick weather," the convoy was forced to put into Falmouth to await "favorable wind."³⁶ Drew wrote to the Admiralty on March 7 to report that he was "still detained by a westerly wind," and that since his arrival in Cork was "of much importance" *DeBraak* might be able to make the journey alone and let the merchant vessels come later.³⁷ Drew apparently was ordered to remain with the merchant vessels.

When more favorable weather finally came *DeBraak* sailed out of Falmouth with "30 Americans [ships] and Four English vessels" and their arrival off Galley Head on March 26 was reported by Captain Pender.³⁸ Drew reported to Pender as ordered and the assembled convoy began preparations for the crossing to North America.

Pender and Drew had been ordered to proceed with the convoy "towards their places of destination (keeping during [their] course to the southward as circumstances [would] permit)" and that upon nearing American waters *DeBraak* "and such Ships and Vessels as may be bound to Georgia and South Carolina" were to depart the rest of the convoy. Drew was instructed to "use his best endeavours to see [the merchant ships] in safety off their respective ports ... and to repair without loss of time to Halifax ... and put himself under the command of Vice Admiral George Vandeput, Commander in Chief of His Majesty's Ships and Vessels on that Station." Pender was to proceed with the rest of the convoy bound for the Chesapeake Bay, Delaware River, New York, and the ports of New England and then to proceed to Halifax.³⁹

The need for these armed convoys stemmed from the hostilities with France. Vessels of the Revolutionary French government preyed mercilessly on the maritime commerce of England and her allies. Lloyd's of London, the largest marine insurance business in the world, required its under-written merchant vessels to sail in these convoys. The Convoy Act of 1793 and the Compulsory Convoy Act of 1798 were passed in order to make it obligatory for almost the entire British mercantile marine to travel with convoys. Ships' masters had to sign written agreements that they would not sail independently or separate from convoys once at sea. Owners of merchant ships were required to help offset the expense of these convoys to the crown.⁴⁰

American shipping also had begun to suffer at the hands of a former ally. For the United States, the war between France and England had provided lucrative trading opportunities. As a neutral country America could take advantage of the situation and ship exports to both France and England. When the United States ratified Jay's Treaty with England in 1796, France decided to step up harassment of American shipping. Since the outbreak of the war in Europe in 1793, France had been trying to pressure the United States into taking a more pro-French position. When this subtle diplomatic approach failed, France decreed in January of 1798 that all ships, no matter what nationality, that were carrying British goods would be considered "bonne prise." Both French privateers and naval vessels alike preyed heavily on American shipping after this decree. This situation led to the United States and France engaging in a "quasi-war" at sea which lasted from 1798 to 1801.⁴¹

The convoy had been at sea less than a week when Pender ordered *DeBraak* to investigate strange sails observed on the horizon. The two ships turned out to be a British man-of-war, H.M.S. *Magnamine*, and a French privateer, *Victory*, which had been taken as a prize.⁴² The weather had begun to deteriorate again and *DeBraak* could not rejoin the convoy. On April 2 Pender recorded in his log that he had forty-seven of the convoy's ships in sight and that *DeBraak* was "almost out of sight... on a stern bearing NE by N45."⁴³ Pender eventually lost sight of *DeBraak* completely and continued according to his orders, delivering the merchant vessels off their ports. *St. Albans* arrived off the Delaware Capes early on May 25 and then continued on to Halifax. Oddly enough, at 4 p.m. that same afternoon *DeBraak* arrived off Cape Henlopen, Delaware with a Spanish prize in company.

Where had *DeBraak* been, and how did she come to have captured a Spanish vessel? This "blank page" in *DeBraak's* history has, perhaps more than any other factor, contributed to the growth of the myth and fantasy concerning the ship's exploits.

The most widely accepted "myth" is that Drew was sailing with "secret orders" to harass the enemies of the crown in the Caribbean. Legend also has it that *DeBraak* made port in Kingston, Jamaica to take on board the payroll for the Halifax garrison and a cargo of gold from the Dutch West India Company. Both of these assertions are absurd because the Halifax garrison was paid in local currency and the Dutch West India Company had ceased to exist prior to *DeBraak's* capture by the British.⁴⁴

Local legend in coastal Delaware maintains that *DeBraak* went on a raiding rampage in the Caribbean. During this campaign *DeBraak* supposedly took no fewer than ten Spanish vessels, including several ships carrying treasure back to Spain, slaughtering the hapless crews and tossing their bodies into the sea to be devoured by frenzied schools of sharks.⁴⁵

The only thing that can be proven about this "missing" part of *DeBraak's* voyage is that somewhere off the coast of North America she did encounter and capture a Spanish merchant vessel, *Don Francisco Xavier*, which was outbound from La Plata for Spain with a cargo of two hundred tons of copper ingots and a large quantity of cocoa beans. From a document located in the records of *DeBraak's* Master, Lieutenant Thomas Griffiths, who survived the sinking, it was learned that Drew ordered Griffiths and a prize crew to go aboard the Spanish ship and to take "all possible Care not to part company" In the event that an unavoidable separation took place he was "to repair to Cape Henry in the Chesapeak[e]" and wait there for *DeBraak*.⁴⁶ Fifteen Spanish seamen were taken off *Don Francisco Xavier* and made prisoners aboard *DeBraak*. The Englishmen stripped the Spanish of their possessions and took the booty on board *DeBraak*. They also removed a number of muskets and pistols, as well as all of the gold and silver coins that could be taken from the captain and crew.⁴⁷

It is likely that once *DeBraak* became separated from the rest of the convoy Drew tried to make the best time possible toward his destination in hopes of rejoining the other British ships. Drew's orders were explicit: he was not to part company with the rest of the convoy. As he was an officer

with nearly thirty years' service in the Royal Navy and had tried desperately to get appointed to a command, it is not likely that he went prowling for prizes.⁴⁸ *DeBraak* probably stumbled across *Don Francisco Xavier* and took her as a prize of opportunity.

When Drew failed to locate the rest of the convoy at the southern ports, he took his ship and the prize north with the intention of either catching up with *St. Albans* or making for Halifax alone. On May 25 the vessels appeared off Cape Henlopen, Delaware to take on fresh water. The weather in that area is extremely unpredictable and the currents at the mouth of the Delaware Bay can be treacherous. A sudden squall blew up, and *DeBraak* was blown over and sank almost immediately. An article in the May 28, 1798 Philadelphia Gazette reported the tragedy:

MELANCHOLY ACCIDENT

By Mr. Vincent Low, who arrived from Cape Henlopen yesterday afternoon, we have received the melancholy news of the loss of his Britannic Majesty's sloop of war Braak, capt. Drew, which overset in Old Kiln Roads, about 4 o'clock last Friday afternoon. She was at the time under main sail and reefed top-sail just about to cast anchor, a mile from the light-house, her boat alongside waiting for the captain, who intended to go on shore at Lewis-town: a sudden flaw of wind laid her down on her beam-ends; she immediately filled and went down, with Capt. Drew, his lieutenant, and 38 officers, seamen, and marines! The rest of the ship's company, about 25, including the boatswain, escaped in the boats, and several were taken up by a pilotboat.

The Braak parted with the fleet off the Western Islands, in chase of a strange sail, and was unable to rejoin the convoy. About twenty five days ago she fell in with and captured a Spanish ship from La

Plata bound to Spain, with a very valuable cargo consisting of 200 tons of copper in bars, a quantity of cocoa, &c. The Prize is arrived in the Delaware. 12 of the prisoners were lost in the sloop of war. The unfortunate captain Drew was in mourning for his brother captain Drew of the Cerberus frigate, who was drowned in Plymouth Sound on the 15th of January last, and at the moment the vessel overset, his servant was in the act of tying on his scarf.⁴⁹

The scene on board *DeBraak* must have been terrifying. With little time to react, the men below decks had almost no hope for survival as the water poured in on them through the open hatches and they were pinned beneath shifting cargo and ballast. Screams of panic in both English and Spanish must have filled the air, only to be quickly cut off as the sea enveloped the doomed men. It was probably even worse for most of the Spanish prisoners, who were reported to have been shackled to the carronades on *DeBraak's* deck. Three prisoners did survive the sinking and local legend has it that they floated to shore on Captain Drew's sea chest, which now resides in a museum in Lewes, Delaware.

Drew's body washed ashore several days later, along with the bodies of several of his crew. The captain was buried in a local churchyard and his monument can still be seen today. The other members of the crew were buried in a sailor's cemetery, which is today under the parking lot for the modern Delaware River Pilots Association headquarters in Lewes.

The British consul in Philadelphia, Phineas Bond, was informed of the tragedy and on May 28 wrote to Lord Grenville, the Secretary of State for Foreign Affairs, to inform him of the incident. Bond's letter included a list of men drowned which was compiled "to the best of his knowledge by the

Boatswain, Jas. Williams" and a list of persons "now on board the Ship Commerce of London\Prize of HM Sloop Braak."⁵⁰ The name "Commerce of London" seems to be a code word for vessels taken as prizes for the Crown and appears in several pieces of correspondence.

Bond apparently also informed Vice Admiral Vandeput in Halifax of *DeBraak's* loss. Vandeput dispatched H.M.S. *Assistance*, Captain Jonathan Oakes Hardy, to Delaware to survey the situation and to determine the feasibility of raising *DeBraak*. On July 22nd Hardy reported to Bond that DeBraak was "driven in 13 fatm [fathoms] water and must have been so violently shook be full of Sand and Mud so as to render my Exertions to sweep under her Bottom very uncertain is the Effect and also very equivocal whether the Expense would not be very great of the undertaking, so much to outweigh the Returns to Government." He went on to suggest that the salvage operation be contracted out with payment based on what was actually recovered from the ship.⁵¹

Hardy also reported that he had learned that several of the crew members from *DeBraak* had since deserted and "been received into Ships of War of the States."⁵² Desertion was a major problem for the Royal Navy since pay was low, officers were often brutal, and many men had been "pressed" into service. Conditions and pay were much better in the United States Navy and on board American merchant vessels.

Don Francisco Xavier was meanwhile at New Castle, Delaware, where she would be safe from French privateers which were known to have been operating off the coast. These privateers were becoming bold in their *guerre de course* against American and English ships and often took prizes within

within sight of land.⁵³ Captain Hardy had been informed that *Debraak's* Master, Mr. Griffiths, was in such a "state of mind as to require confinement."⁵⁴ Exactly what the problem with Griffiths was is not specified, but apparently the entire crew on board the prize were becoming unruly. Finally, a lieutenant, a midshipman and two trusty seamen had to be sent down from H.M.S. *Latropaze*, which was at Sandy Hook, New Jersey, to take charge of the prize and her crew.⁵⁵ It can only be assumed that the problem on board the prize was such that these four new men would be able to control the situation.

In the meantime Bond had received word from Halifax directing him to take the necessary steps toward salvaging *DeBraak*. He contacted Hardy requesting information on the number of vessels, type of equipment, personnel, etc. that would be required to weigh (lift) the ship. To this Hardy replied that the undertaking would require at least "four Vessels of about 80 Tons Burden each" and that they "must be well found with Cables & anchors & good windlasses." In a postscript he went on further to state that "The necessary Tackle for weighing [*DeBraak*] would be two Cables of 13 Inch - Four Hausers of 7 Inch Four Setts of heaving down Blocks that will serve the said Hausers" and that all four vessels used "must be well found with Greased Tackle." Also, that Bond should obtain all of the pumps that he could locate and that these must be "by no means omitted."⁵⁶

Bond immediately set about to locate and to make conditional contracts with the necessary ship owners, but found "a total Repugnance in them" about undertaking the operation for only an "Allowance of Salvage."⁵⁷ He was finally able to engage four vessels "at the Rate of 50\$ [fifty dollars] a

Day," but these barely had enough men to navigate them, much less carry out the salvage work. Bond informed Hardy of this and expressed "a Confidence that Seamen would be supplied from the *Assistance* " to make up the needed manpower. The owners of the four vessels had hired a Captain Franklin to take charge of the ships and to supervise their outfitting at a rate of three dollars per day.⁵⁸ It is not clear whether or not Franklin was expected to direct the proposed salvage operations.

Meanwhile, H.M.S. *Rover* had been dispatched from Cape Breton to the Delaware for the purpose of convoying *DeBraak's* prize to Halifax. Shortly thereafter *Rover* was lost at sea with all hands off Cape Breton. Hardy was informed of this loss in a dispatch from Vice Admiral Vandeput. The admiral also ordered *Assistance* to replace the unfortunate *Rover* in convoying the prize.⁵⁹ This dispatch was included with a letter from Bond inquiring if *Assistance* could also "convoy Trade from the Delaware."⁶⁰ Hardy replied that his orders were to escort the prize only, but that any vessels ready for sea as soon as the prize could join the convoy.⁶¹

Hardy then sent the Master of *Assistance*, Mr. Seargill, to take charge of the prize and prepare to bring her down the Delaware. Seargill was also to inspect the hired vessels as to their fitness and readiness for the salvage operation and soon became "Zealously engaged" in both of these charges.⁶²

Mistakenly assuming that *Assistance* would remain and aid in *DeBraak's* salvage, Bond wrote to Hardy on August 8 expressing his hopes that Hardy would consider that effort and the escorting of the prize "as combined" and that he should do all he could toward those ends before leaving the Delaware for Halifax. Also since the prize had been furnished

with new cables "she could lay securely in the Road [Whore Kiln Road at Lewistown] while Attempt was making to weigh the Sloop of War."⁶³ Bond's continued thoughts along these lines are strange since Hardy had made it clear in earlier correspondence that he was not going to assist in the salvage.

Due to difficulties in acquiring the needed cordage for the salvage operation Bond informed Hardy that the hired vessels would not all be ready until August 17. He also stressed that all of the pumps, blocks, cordage, etc., that were purchased or hired by the crown were to be retrieved from the salvage vessels once the operation was over. Bond added that should *DeBraak* be raised "she was not to be sent to Philadelphia where a contagion had already shown itself," but was to be taken to "Wilmington or Marcus Hook... where her Outfit was to be conducted." Hardy was also directed to take precautions because "many Valuables were on Board [*DeBraak*]."⁶⁴ It may be that treasure hunters throughout the years have read the word "Valuables" in this final line as "Treasure." It is much more likely that Bond was referring to the ship's cannons, stores, crews' belongings, and other relatively new equipment on board *DeBraak*.

The outfitting of the hired vessels progressed faster than had been expected and on Tuesday, August 7 they and the prize began dropping down the Delaware River, finally anchoring in Whore Kiln Road on the eighth, at which time Captain Franklin offered to put himself under the command of Captain Hardy.⁶⁵ This was too much for Hardy. His correspondence with Bond was becoming almost absurd. On the one hand, Hardy had stressed that his orders were to put to sea for Halifax as soon as *DeBraak's* prize

arrived from Philadelphia, and that he had no intention of directing the salvage operation. Then, seeming to ignore this, Bond had written that he would send the salvage vessels down with the prize and Hardy could direct the salvage operation and provide men. Bond may well have been an overzealous bureaucrat who was reading into Hardy's words that which would make himself look the best to his superiors.

Realizing that the prize would soon be at the Capes of the Delaware, Hardy sent the salvage vessels back to Philadelphia on the eleventh with several sharply worded letters for Mr. Bond. Hardy wrote that he was "extremely sorry that [Bond] could possibly misconceive" of his intentions concerning the salvage of *DeBraak*, noting that he had expressed "in the most explicit manner" that his schedule depended entirely upon the arrival of the prize. He went on further to state that "the Admiral never intended to employ His Majs Ships" in the salvage operations and that he was "certain that the Admiral would highly disapprove of the great daily Expense of 200 dollars for Vessels only without men" and that for that amount of money the salvors "ought to find as many [men] as are necessary." With *DeBraak's* prize then in sight, Hardy continued, he could not justify "detaining His Majesty's Ship a Moment Longer."⁶⁶

Hardy was true to his word on this point and When Seargill arrived with *DeBraak's* prize, preparations were begun for departure to Halifax.⁶⁷ On Monday, August 13, *Assistance* and *Don Francisco Xavier* sailed out of the Delaware with the ebbing tide and made for Halifax. They arrived at that port without incident on August 27.⁶⁸ En route, *DeBraak's* boatswain, master's mate and surviving marines were entered into the muster book of

into the muster book of *Assistance*.⁶⁹ The status and disposition of the other surviving crew members is not known.

In the meantime Vice Admiral Vandeput in Halifax had not been idle. Having been informed of Hardy's refusal to assist in the salvage of *DeBraak* and of the good possibilities of raising her, he had ordered two vessels at Halifax to prepare to sail for the Delaware Bay and to attempt to raise the sunken brig. The vessels were H.M.S. *Hind*, commanded by Lieutenant Joseph Larcom, and the brig *Vixen*, which was specially fitted out for salvage and manned by Captain Dunbar and forty-five men from H.M.S. *Spencer*.⁷⁰ The salvage vessels sailed for the Delaware on September 3, arriving at their destination on September 15. It is interesting that *St. Albans*, the sixty-four-gun ship from *DeBraak's* convoy, arrived in Halifax on September 2, having safely convoyed the last of the American merchant vessels to ports in New England.⁷¹

Upon arriving at the Delaware Bay, the salvage vessels immediately began preparations for raising *DeBraak*. The methods to be employed in attempting to raise the ship had been in use for some time and were often successful in salvaging ships under similar circumstances. Beginning on September 16, *Hind* and *Vixen* began sweeping for *Debraak*.⁷² This consisted of laying out a weighted cable, thirteen inches in circumference, between the two ships and attempting to pull the cable under the sunken ship's hull. If this were accomplished, the salvage vessels could then try, using the forces of wind or current or both, to drag *DeBraak* into shallow water, where the pumps could be used to remove water from the interior of the ship and refloat her.

As it turned out, all attempts to raise the sunken brig failed. Sweeps on the seventeenth succeeded in recovering only one of *DeBraak's* bower anchors with a cable and buoy rope attached to it. The thirteen-inch cable was also lost on that day. The recovered anchor was cut in two and used to weight another sweep, which on the eighteenth managed to haul up a studding sail boom. On the nineteenth another attempt was made and in the afternoon the small bower sweep was carried away because of the strain. Lieutenant Larcom noted in his log that night that "at 11 [we] gave it over, finding we could not lift here [her?] and our spare cables being broke. Lost kedge anchor & 6" hawser. Sailed, VIXON in company."⁷³

Hind and *Vixon* arrived back at Halifax on October 1. A small boat was sent out from the navy yard to where the vessels were moored and took off the blocks, cables and other equipment that had been used in the attempted salvage. Vice Admiral Vandeput was informed of the failed salvage of *DeBraak*. He wrote to the Admiralty Board reporting this and stated that he was of the opinion that all practicable means of salvage had been used and that no more effort should be expended. The Admiralty Board agreed.⁷⁴

The one and only attempt by the British to raise *DeBraak* had failed. There can be little doubt that had there been a substantial amount of "treasure" on board the ship, other attempts would have been made. The ship's location was known for years after her sinking; the tops of her masts still protruded above the surface of Delaware Bay for at least two years. In the relatively shallow depths in which *DeBraak* lay, about eighty feet, free divers such as those used to harvest sponges could have entered the hull to

recover valuables. Crude diving bells were also in common use at the time. These had been used successfully in both the old and new worlds to recover heavy ordnance and treasure from sunken ships. *DeBraak* was written off by the Admiralty because she was an old ship, despite her refitting and new equipment, and because they felt that the expense of salvage would outweigh any return that could be realized from such an operation. The vast treasure in gold, silver and jewels that has been envisioned by generations of treasure hunters and other romantics would surely have been worth the effort.

As for *DeBraak's* prize, *Don Francisco Xavier*, she was auctioned off in prize court in Halifax. Some of the survivors received their shares there in October of 1799, while the remainder were informed in Steel's Royal Navy Lists in London on March 6, 1800 that:

Notice is given to the Second, Fourth and Fifth Classes of the surviving Officers and Company of His Majesty's late Sloop of War *DeBraak*, James Drew, Esq; Commander, who were actually on board at the Capture of the Spanish Prize *Don Francisco Xavier*, about the Month of May 1798, who have not been paid at Halifax, in Nova Scotia, and likewise to the legal Representatives of Such Officers, Seamen, & any of the above Classes as were unfortunately lost in the *De Braak*, and who have not been paid as above mentioned, that they will be paid their respective Shares of the said Prize, at the Sign of the crown and Sugar-Loaf, on Garrow-Lick-Hill, London, on Thursday the 13th Instant; and that the Shares not then demanded will be recalled at the same Place the first Monday of every Month for Three Years from the Month of October last, when Payment was made at Halifax.

Wm. Goodall and John Turner, for Fore-

man, Grassie and Co. Halifax, Nova Scotia,
Agents.⁷⁵

Receiving their shares of the prize money was not the only source of financial worry for *DeBraak's* survivors. On December 1, 1799 Captain George Tobin of H.M.S. *Dasher* wrote to the Admiralty to report that he had on board ten seamen from *DeBraak* whom he had been informed by the Navy Board could not be paid their back wages "until a Court Martial [was] held." He requested that such measures be taken in the case "as will entitle those men to recover the Wages due to them."⁷⁶ In response to this, the Admiralty wrote to Vice Admiral Vandeput at Halifax asking if he had ordered a court martial to enquire into the cause and circumstances of the loss of *DeBraak* and, if not, to do so at the first opportunity and transmit the court's sentence to them.⁷⁷

No record of a court martial has been located in either London or Halifax. Had there been one there would more than likely be a record of it somewhere. It is possible that depositions were taken from all of the survivors of *DeBraak* and a determination was made by Vandeput that no court martial was warranted in this case, as all of the responsible officers were dead. There may have been a simple court of inquiry into the incident.

Some steps were obviously taken to remedy the situation. The pay book of *DeBraak*, dated January 9, 1801, notes that at least eight of the seamen on whose behalf Captain Tobin wrote were paid back-wages on that date.⁷⁸ The last payment of this kind was made on May 14, 1822 to Sarah Williams, the widow of *DeBraak's* boatswain, James Williams.⁷⁹ Apparently red tape

tape in the late eighteenth and early nineteenth centuries was as frustrating as it is today.

DeBraak's hulk lay rotting in her watery grave. Tored worms began to devour her oak hull and pine planking. Her masts eventually were carried away by the tides, leaving no visible sign of her resting place. The lower portions of her hull, listing to starboard, filled with fine silt, sand and light gravel, sealing her remains in an anaerobic tomb. The British navy had long since forgotten her, but the citizens of coastal Delaware did not forget. To them, the legend of *DeBraak's* fabulous treasure became something to pass down through the generations. With each passing generation the tales of treasure multiplied. Such a vast amount of wealth waiting just off the shore would attract many souls who would have it for their own. As man's ability to penetrate and explore the mysteries of the sea improved, the chances for some searcher to locate and salvage *DeBraak* increased.

ENDNOTES

- ¹ Author unknown, "Meloncholy Accident," Philadelphia Gazette, May 28, 1798.
- ² "Meloncholy Accident."
- ³ J.F. Van Dulm to Paul E. Smith, March 26, 1964, *DeBraak* File, Zwaanendael Museum, Lewes, Delaware.
- ⁴ J.C. Van Oosten to J.B. DeSwart, July 24, 1973, *DeBraak* File.
- ⁵ David Hebb, personal communication, May 30, 1988. Mr. Hebb, a researcher with the University of London, related this information to the author while visiting the *DeBraak* project facility. "LE PATROCLE 1781" is cast into a ship's bell recovered from *DeBraak's* wrecksite. Patrocles was a Macedonian general (c. 312-261 B.C.) who commanded the fleet of Seleucus I and undertook a voyage of exploration on the Caspian Sea.
- ⁶ David Lyon, personal communication, January 7, 1989. Mr. Lyon is Head of Inquiry Services at the National Maritime Museum in London.
- ⁷ Van Dulm to Smith, 1964, *DeBraak* File.
- ⁸ Van Dulm to Smith, 1964, *DeBraak* File.
- ⁹ Georges leFabvre, The French Revolution From 1793 to 1799, trans. John Hall Stewart and James Friguglietti (New York: Columbia University Press, 1964), p. 14.
- ¹⁰ Van Dulm to Smith, 1964, *DeBraak* File.
- ¹¹ E. H. Kossman, The Low Countries: 1780-1940, (Oxford, England: Clarendon Press, 1978), pp. 82-84.
- ¹² Van Dulm to Smith, 1964, *DeBraak* File. Howard I. Chapelle and Lt. Col. M.E.S. Laws, "H.M.S. *DeBraak*: The Stories of a Treasure Ship," Smithsonian Journal of History, Spring 1967, p. 58.
- ¹³ Navy Board to Admiralty, September 10, 1796, Admiralty Records 106/2088, Public Record Office, London.
- ¹⁴ Spencer, Pybus and Gambier to Dundas, July 18, 1795, Navy Board Out Letters, Admiralty Records 2/374, Public Record Office, London.
- ¹⁵ Chapelle and Laws, "Treasure," p. 59.
- ¹⁶ Chapelle and Laws, "Treasure," p. 59.
- ¹⁷ Navy Board to Admiralty, September 10, 1796, ADM 106/2088.
- ¹⁸ *DeBraak* "as when taken" and "as fitted" Plans, Registrations 6346 and 6347, Box 65, National Maritime Museum, London.

19 *DeBraak* as when taken, N.M.M. Details of this conversion will be discussed in a later chapter.

20 Chapelle and Laws, "Treasure," p. 58. They state that: "*DeBraak*, rigged as a cutter, required a large crew for a vessel of her dimensions, and officers had to have training in handling so large a single-master. For these reasons, the rig was not popular in the Royal Navy except in small vessels, ones under about sixty-five feet in deck length."

21 Chapelle and Laws, "Treasure," p. 59.

22 Navy Board to Admiralty, June 13, 1797, ADM 106/2088.

23 James Drew to Evan Nepean, September 13, 1797, Admiralty in Letters, Admiralty Records, 1/1719, Public Record Office, London.

24 Navy Board to Admiralty, October 11, 1797, ADM 106/2088.

25 Drew to Nepean, July 16, 1797, ADM 1/1719.

26 Navy Board to Mr. Marsden, December 11, 1797, ADM 1/1719.

27 Navy Board to Admiralty, December 16, 1797, ADM 106/2088.

28 Donald Shomette and Fred Hopkins, personal communication. Messrs. Shomette and Hopkins of Nautical Archaeological Associates, Inc., of Upper Marlboro, Maryland have been studying *DeBraak's* rigging elements. This study has concluded that much of the rigging was twice the size specified for a vessel of *DeBraak's* size.

29 Chapelle and Laws, "Treasure," p. 64.

30 Chapelle and Laws, "Treasure," p. 60.

31 Admiralty to Captain Francis Pender, February 23, 1798, Admiralty Out Letters, Admiralty Records, Public Record Office, London.

32 Drew to Nepean, February 18, 1798, Captains' Letters "D", Admiralty Records, Public Record Office, London.

33 Drew to Nepean, June 26, 1797, ADM 1/1719.

34 Drew to Nepean, September 27, 1797, ADM 1/1719.

35 From an inscription on a monument erected by the Drew family at the family church in Saltash, County Cornwall, England. This monument depicts two men floundering in the sea in one relief and one man near a sinking ship with a lighthouse in the background (Henlopen Light) in another. The three men are also depicted in relief busts in profile on the monument.

36 Drew to Nepean, March 2, 1798, ADM 1/1720.

37 Drew to Nepean, March 7, 1798, ADM 1/1720.

38 Pender to Admiralty, March 26, 1798, ADM 1/1720.

39 Admiralty to Pender, February 23, 1798, ADM 2/1099.

40G. J. Marcus, A Naval History of England: The Formative Centuries, (London: Longmans, 1961), pp. 410-411.

41Michael Palmer, Stoddert's War: Naval Operations During the Quasi-War With France, 1798-1801, (Columbia, S.C.: University of South Carolina Press, 1987), pp. 3-6.

42Chapelle and Laws, "Treasure," p. 60.

43H.M.S. *St. Albans* Captains' Logs, 26 May, 1797-September 16, 1798, Admiralty Records 51/1272, Public Record Office, London.

44Chapelle and Laws, "Treasure," p. 57.

45Benjamin Hichborn to John Adams, December 10, 1775, William Bell Clark, ed., Naval Documents of the American Revolution, (Washington: U.S. Department of the Navy, 1963-___), III,33. Captain Drew was apparently not above committing such atrocities as those referred to in the legends. Hichborn related to Adams the following:

"One Drew now a Lieutenant of the SCORPION or VIPER [Drew was in the *Scorpion*] I am uncertain which, & Bruce a private belonging to the PRESTON, landed on Bunkers Hill, soon after the battle of the 17th of June. Drew, after walking for some time over the bodies of the dead, with great fortitude, went up to one of our wounded Men, & very Deliberately Shot him through the Head. Bruce advanced further over the Hill, & meeting with a forlorn wretch, begging Mercy for Gods Sake! he advanced and with a "damn you, you Bugger you! are you not dead yet?" instantly demolished him - in a day or two after, Drew went upon the Hill again opened the dirt that was thrown over Doctr [Joseph] Warren, spit in his face, jumped upon his Stomach & at last cut off his head & committed every act of violence upon his Body. I had this story from two Gentlemen belonging to the PRESTON who were eye Witnesses to the facts. in justice to the Officers in general I must add that they despise Drew for his Conduct, the other was below their notice."

46Drew to Lt. Thomas Griffiths, April 20, 1798, Certificates of Service, Masters c. 1800-1850 D to G, Admiralty Records 6/147, Public Record Office, London.

47A number of Spanish artifacts were recovered from *DeBraak's* wrecksite including ceramics, muskets (1751 models), pistols, and gold and silver coins of various denominations.

48Drew to Admiralty, October, 1793-March, 1795, Adm 1/1714. During this period Drew had written repeatedly to the Admiralty requesting an appointment. Finally, in March of 1795, he was put in command of the sloop H.M.S. *Fly*.

49 "Meloncholy Accident."

50 Pheneas Bond to Lord Grenville, May 28, 1798, Special File Proposed Salvage of *DeBraak*, Admiralty Records 1/5121/3, Public Record Office, London.

51 Jonothan Oakes Hardy to Bond, July 22, 1798, ADM 1/5121/3.

52 Hardy to Bond, July 22, 1798, ADM 1/5121/3.

53 South Carolina Gazette and Timothy's Daily Advertiser, June 13, 1798. From Philadelphia on May 26, 1798 it was reported that the schooner *Liberty* bound from Philadelphia, was chased by a French privateer around 5 o'clock P.M. on May 24 a "full four miles within the Capes of the Delaware." Jeremy Black and Philip Woodfine, eds., The British Navy and the Use of Naval Power in the Eighteenth Century, (Leicester: Leicester University Press, 1988), p. 41.

54 Hardy to Bond, July 27, 1798, ADM 1/5121/3.

55 Bond to Hardy, July 30, 1798, ADM 1/5121/3.

56 Hardy to Bond, July 27, 1798, ADM 1/5121/3.

57 Bond to Hardy, July 30, 1798, ADM 1/5121/3.

58 Bond to Hardy, August 1, 1798, ADM 1/5121/3.

59 Vice Admiral George Vandeput to Hardy via Bond, July 8, 1798, ADM 1/5121/3.

60 Bond to Hardy, July 26, 1798, ADM 1/5121/3.

61 Hardy to Bond, July 31, 1798, ADM 1/5121/3.

62 Hardy to Bond, July 31, 1798, ADM 1/5121/3.

63 Bond to Hardy, August 5, 1798, ADM 1/5121/3.

64 Bond to Hardy, August 6, 1798, ADM 1/5121/3.

65 Bond to Hardy, August 8, 1798, ADM 1/5121/3.

66 Hardy to Bond, August 11, 1798, ADM 1/5121/3.

67 H.M.S. *Assistance*, Masters' Logs 14 May 1798-13 May 1799, Admiralty Records 52/2725, Public Record Office, London.

68 H.M.S. *Assistance*, 5 June, 1798-4 June, 1799, ADM 51/1258.

69 H.M.S. *Assistance*, Muster Books 1798-1799, Admiralty Records, Public Record Office, London.

70 Chapelle and Laws, "Treasure," p. 62. H.M.S. *Hind* 17 May, 1798-17 May, 1799, ADM 52/2725.

71 H.M.S. *Hind* 17 May, 1798-17 May, 1799, ADM 51/1296. H.M.S. *Assistance*, 14 May, 1798-13 May, 1799, ADM 52/2725.

72 H.M.S. *Hind* 17 May, 1798-17 May, 1799, ADM 51/1296.

- 73 H.M.S. *Hind* 17 May, 1798-17 May, 1799, ADM 51/1296.
- 74 Chappelle and Laws, "Treasure," p. 62.
- 75 Steel's Royal Navy Lists, March 6, 1800, p. 229.
- 76 Captain George Tobin to Admiralty, December 1, 1799, Captains Letters "T", ref. 31,1-Damage and Loss at Sea, 103 Gen., Cap T 137, Admiralty Records 1/2599, Public Record Office, London.
- 77 Admiralty to Vandeput, December 22, 1799, Secretary's Letters to Commanders in Chief, Halifax 1795-1807, Admiralty Records 2/931, Public Record Office, London.
- 78 *DeBraak* Pay Book, January 9, 1801, Admiralty Records 35/211, Public Record Office, London.
- 79 *DeBraak*, May 14, 1822, ADM 35/211.

CHAPTER II

THE SEARCH FOR *DEBRAAK*

The first known attempt to locate and salvage *DeBraak* after the British had abandoned the wreck did not occur until 1889. That year the Pancoast Expedition (named after Dr. Seth Pancoast, who organized the search) was organized, apparently with a federal permit to search for and recover material from the wreck. With the assistance of the International Submarine Company, this expedition used commercial divers and a marine derrick in its operations. At one point a diver encountered a large chain, which was thought to extend under a wreck. The derrick could not move this chain and it is not known whether the wreck located was that of *DeBraak*.¹

In 1932 the Braak Corporation was set up by Ralph E. Chapman of New York City to search for *DeBraak*. He was a partner in Merritt, Chapman and Scott, then one of the largest marine contracting firms in the country. Other partners in this venture were the Baltimore Derrick and Salvage Company and the London Salvage Company. A Captain Johnson of Lewes was hired as a local consultant.²

This company was armed with something that the previous salvors lacked: a map showing the location of the wreck. This map had been drawn by a local pilot, Gilbert McCracken, who was the partner of the pilot who had been aboard *DeBraak* when she sank. Local lore has it that McCracken took a surviving Spanish prisoner home with him after the sinking. The Spaniard supposedly told him of a fortune in coins and bullion taken by *DeBraak*

from two Spanish ships out-bound from South America. This former prisoner supposedly held some gold bars in his hands as he told his tale.³ (How this man was able to lay his hands on these gold bars while the ship was sinking is not clear.) With this information, McCracken went out to Cape Henlopen and drew the map in his family bible. This map gave a single bearing from the old Henlopen Lighthouse.

Using the McCracken map, the salvors located a wreck along that bearing. This wreck, as well as several others found by divers, was reportedly constructed of teak. These salvors, and others who came before and after them, were somehow under the assumption that *DeBraak* was built in the East Indies of teak. Not being able to determine which "teak wreck" was the one they were after, the salvors gave up after rough winter weather set in.⁴

During the winter of 1935 and 1936 another expedition set out to locate the famed *DeBraak*. This search was led by Charles N. Colstead of Providence, Rhode Island.⁵ No information as to the results of this operation are available, but it can be assumed that it too failed to locate the wreck site.

Not all of the would-be treasure hunters felt that they had to search beneath the waves in order to find *DeBraak's* mother lode. In 1937 Captain James Bartlett, aged 67, decided that the northward migration of Cape Henlopen had covered the wrecksite. In that year Bartlett searched the sands of the cape using a process described as "spiritual magnetism." It can be assumed that this process included the use of some sort of divining rod. Captain Bartlett succeeded in locating only an encrusted iron bar of unknown origin.⁶

In 1955 there was renewed interest in locating *DeBraak*. In that year, two Pennsylvania men, Robert Howarth and Dr. William Boyce, applied for and received a lease for a 4,750' by 6,070' section of state bottom lands east of Cape Henlopen where they intended to search for *DeBraak*. This lease cost them twenty-five dollars per month. The lease was canceled in January of 1956 when the area was included in the Fort Miles Restricted Zone. The Navy had complained that all of the concentrated boat activity in the area was interfering with the marine acoustical equipment used for detecting submarines.⁷

One of the more mysterious proposed salvage attempts came in July of 1956 when an attorney from Wilmington, North Carolina, Edgar L. Yow, received a salvage permit from the Delaware State Highway Department on behalf of several anonymous clients. The names of these clients have never been discovered. Why they wished to remain anonymous is not clear. The state agreed that the salvage attempt could take place if several terms were met. First, the salvors would have to lease the search area for twenty-five dollars per month. Second, the state would get ten percent of the gross profits of the salvaged material. And third, the Navy would have to approve of the operation. The Navy disapproved.⁸

Between 1965 and 1969 D & D Salvage, a Philadelphia based company, searched for *DeBraak* under salvage permits issued first by Governor Charles L. Terry and later by Governor Russell W. Peterson. Under the terms of these permits the state would receive twenty-five percent of the net profits generated by the project. This time the Navy gave the go-ahead for the salvage operations.⁹

Early in this project the salvors used several non-destructive methods, including an airplane-towed magnetometer, to locate the wreck. By 1969, however, they stepped up their operations to include the use of a marine derrick and an eleven cubic yard clamshell bucket. With this latter destructive methodology the salvors managed to dredge up a vessel that contained a variety of ships' fittings of undetermined age and a quantity of horse tack such as bridles and stirrups. Alan B. Albright, then an underwater archeologist with the Smithsonian Institute, was asked by Governor Peterson to inspect this material and to determine whether or not it could have come off *DeBraak*. Albright determined that the artifacts recovered from this wreck had not come from a late-eighteenth-century British man-of-war.¹⁰

A new twist in the search for *DeBraak* came in 1973. Steve Snyder of Cherry Hill, New Jersey decided to search for the wreck, not to find treasure, but because of its significance to the folklore of the area. Snyder had been researching the British Admiralty records and was of the opinion that the ship did not contain, and had never contained, treasure. This new search was to incorporate the use of state-of-the-art remote sensing equipment such as side-scan sonar and proton magnetometer. Due to lack of funds, however, the project never got started.¹¹

Treasure fever struck again in 1980 when a company named Seaborne Ventures arrived in Delaware to search for *DeBraak's* fabled horde of precious metals and jewels. This group searched an area south of Cape Henlopen and located several wrecks, but no *DeBraak*.

Under a lease granted by the state, Seaborne Ventures proceeded to clamshell into splinters a wreck north of Indian River Inlet which was thought to have been *Faithful Steward*. This vessel grounded in that area in 1785 with the loss of over two hundred lives, mostly poor Scottish immigrants. For their efforts the salvors were rewarded with 150 copper coins, four gold coins, and numerous buckles, navigational dividers, and other artifacts belonging to the ship and its passengers. No one knows for sure what happened to this material, but the state of Delaware received nothing but the lease fees.¹² An ominous pattern was beginning to emerge that would later affect *DeBraak*: the willingness of the state of Delaware to lease out its submerged cultural resources for "mining" in exchange for a piece of the elusive treasure pie.

The technology for locating objects submerged beneath the water has made some rapid advances in the past thirty years. It was just a matter of time before some determined and enterprising salvors made use of this technology in their search for *DeBraak*. In 1984 was the the search for *DeBraak's* treasure caught up with the available technology.

In that year, a Reno, Nevada-based salvage company, Sub-Sal, Inc., applied for and received a permit to search for shipwrecks off the Delaware coast. Using a state-of-the-art side-scan sonar, the salvors methodically searched a large area east of Cape Henlopen. Going by the original British salvage records, which stated that the wreck lay in thirteen fathoms of water, the survey boat followed the 80-foot contour lines off the coast, keeping their track with a recording fathometer. Six wrecks were located. One of them was *DeBraak* (Fig. 3).¹³

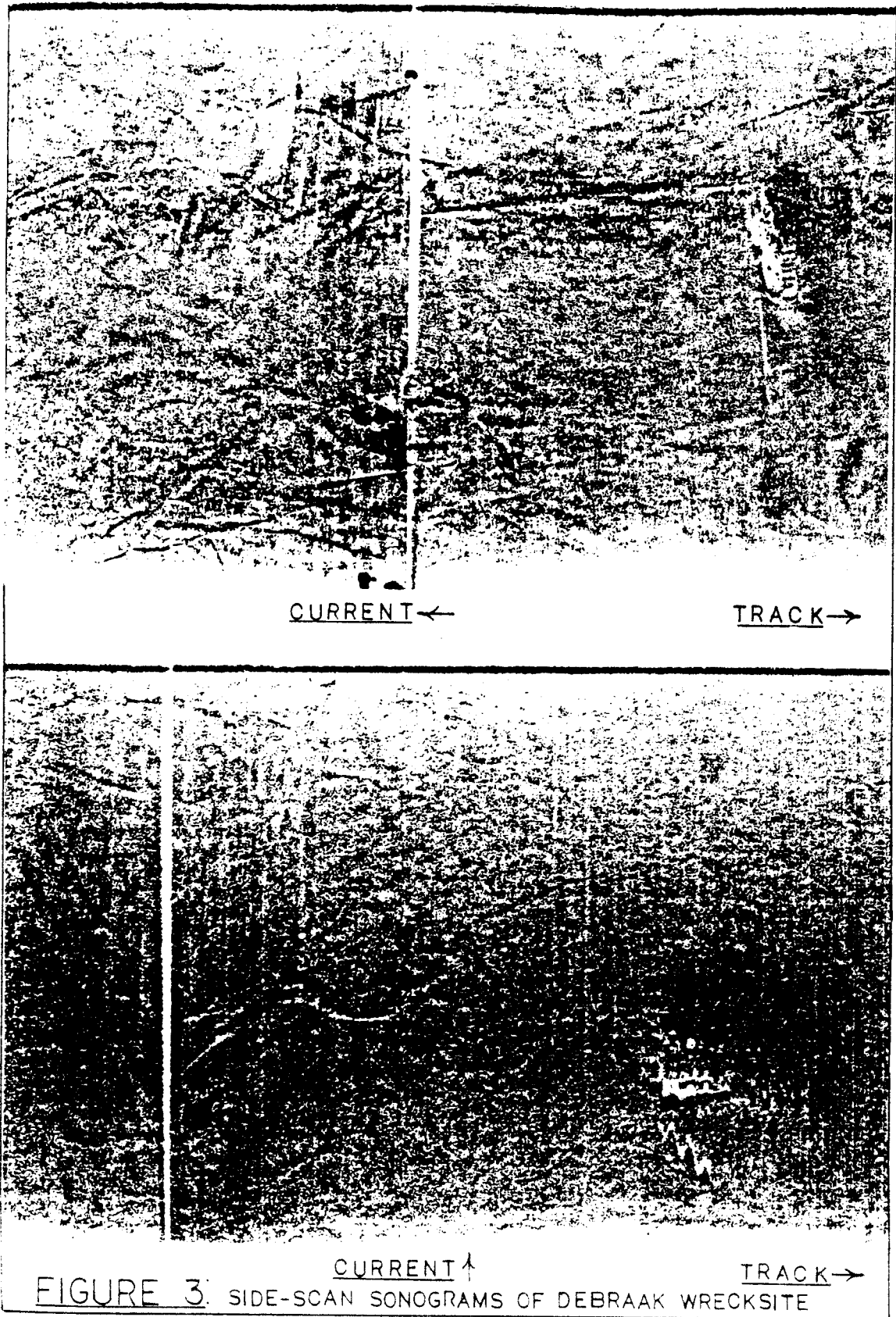

FIGURE 3. SIDE-SCAN SONOGRAMS OF DEBRAAK WRECKSITE

Reconnaissance dives on the site revealed a vertical row of cast iron ballast bars and worm-eaten wood protruding approximately three feet above the ocean floor. Scattered around the site were artifacts that would date to the right period when analyzed, including bottles, ceramics, and rigging elements. Most of what remained of the wreck was buried in bottom sediments.¹⁴

Armed with this information, Sub-Sal went to the state government and applied for a salvage lease. The state initially tried to claim the wreck, but the salvors had "arrested" the site under federal admiralty law and therefore owned the rights to the wreck. The salvors, however, did not own the state bottom lands in which the wreck was buried. Therefore, they had to apply for a lease of these lands from the Delaware Department of Natural Resources and Environmental Controls. Under the terms of this lease, the state would receive twenty-five percent of any "net" profits generated by the salvage operation.

The stage was then set for a three-year salvage operation that would end in one of the worst maritime archeological disasters in recent history. Along the way there would be much intrigue and controversy as the lives and finances of many of the participants in the salvage were ruined and rival salvors battled it out in court over control of *DeBraak* and her legendary treasure. But that part of this story would fill volumes in itself and will therefore only be touched upon as needed for clarity in the following chapters.

ENDNOTES

- 1 Wilmington Morning News, February 16, 1937.
- 2 Saturday Evening Post, February 13, 1954.
- 3 Post, 1954.
- 4 Post, 1954.
- 5 Post, 1954.
- 6 Morning News, February 16, 1937.
- 7 Morning News, July 18, 1956.
- 8 Morning News, July 18, 1956.
- 9 Wilmington Evening Journal, August 3, 1965.
- 10 Baltimore Sunday Bulletin, March 20, 1969.
- 11 Evening Journal, November 5, 1973.
- 12 The Whale, October 22, 1980.
- 13 Harvey Harrington, personal communication, April 10, 1988. Mr. Harrington is the President of Sub-Sal, Inc.
- 14 Harrington, pers. comm.

CHAPTER III
THE SALVAGE OF *DEBRAAK*

Sub-Sal's lease required that a representative of the state be on board the salvage vessel at all times while *DeBraak's* site was being excavated. Initially the Delaware State Police were responsible for this task, but as the number and quality of artifacts being recovered from the site increased the DNREC decided to hire an underwater archeologist to monitor the operations and to record and catalog the artifacts.¹ James Robert Reedy of North Carolina, a student in East Carolina University's Program in Maritime History and Underwater Research, was hired for this position. Reedy's other duties included stabilization and limited conservation of artifacts and regular dives to inspect the progress of the work on the site.

Before excavation on the site was begun the salvage divers, working only at slack tides in scuba gear, surveyed the wreck and collected loose artifacts exposed on the bottom. These first artifacts included a number of cylindrical liquor bottles, a lead sink with a copper alloy stopper, and a large intact Iberian-style storage jar with a bung hole. The latter was probably on deck at the stern of *DeBraak* when she capsized and settled away from the collapsing hull, thus surviving without damage. The uncontrolled collection of these artifacts led to the loss of valuable site data as their provenience was listed by the divers in the grossest of terms (e.g. "the stern of the wreck").

In order to excavate the site in a relatively controlled manner, the salvors initially established an arbitrary baseline running roughly parallel to and 18'

6" inches to the starboard side of the keelson. After several unsuccessful attempts to set up a workable grid system, including the use of military surplus bed frames, 4-by-8-foot grid units were constructed of PVC pipe and connected to the baseline (Fig. 4).²

Due to the conditions on the site, such as depth, high-velocity currents and extremely limited visibility, a full-scale commercial diving operation was instituted in order to maximize efficiency during the excavation. Working from a 65-foot workboat, *Mariner*, Sub-Sal used commercial divers from New England and the Louisiana oil fields for this work. Hard-hat diving equipment with surface-supplied air and communications was used during all diving except that done for observation, photography, and survey at slack tides when scuba gear could be safely used. Information regarding the progress of the excavation and artifacts encountered was relayed by the divers to the surface where it was recorded for later transcription.³

Concentrating in the stern area of the wreck site, the salvors removed the overburden by means of a 6-inch-diameter submerged airlift. Since there was no attempt to screen or monitor the effluent of this airlift, and considering the extreme environmental conditions, there can be little doubt that many small artifacts were lost or contaminated other parts of the site, further confusing the archeological record. Larger artifacts were recovered by hand and placed in wire baskets or nylon-mesh bags for transport to the surface. Once on board the salvage vessel the artifacts were catalogued by the state's representative, stabilized, and transported to a storage facility in Lewes.⁴

Due to the selective nature of the artifact retrieval process, most of the 1984 collection consisted of intact or remarkable examples such as whole bottles and ceramic vessels, small arms hardware, the ship's bell (with the name "LE PATROCLE 1781" cast into it), five carronades and one long gun, and a number of gold and silver coins and pieces of jewelry. The most remarkable and controversial of the latter was a gold mourning ring, supposedly belonging to *DeBraak's* captain, James Drew, with the inscription:

In Loving Memory of a
Beloved Brother
Capt. John Drew
Drown'd 11 Jan. 1798
Aged 47⁵

Due to the onset of severe winter weather and financial difficulties, the salvage operation was halted in late December of 1984. During the winter of 1985, weather permitting, divers using scuba gear continued to survey and photograph *DeBraak's* wreck site in preparation for resumption of full-scale recovery operations slated to begin in the spring.

The summer of 1985 brought new blood and money to the project. New investors from New Hampshire gained controlling interest in Sub-Sal and state oversight of the salvage operations was given to the Delaware Division of Historical and Cultural Affairs. Funds were encumbered to the University of Delaware Center for Archaeological Research to provide offshore monitoring and data management. UDCAR archeologist H. Henry Ward was the state's principal offshore representative. Also assigned to the project was Claudia F. Melson, Curator of Registration for the Bureau of Museums

and Historic Sites, who was responsible for on-shore cataloging and care of the artifacts. James Robert Reedy returned to the project as an archeological consultant and diver for Sub-Sal.⁶

Archeological controls for the 1985 salvage operations were improved dramatically over those used the previous year. A larger vessel, *F/V Sea Star*, an 89-foot stern-trawler, was leased for the project. Besides being fitted with the required equipment for a large scale commercial diving operation (air compressors, recompression chambers, communications equipment, etc.), this vessel also had on board two sluice-box and screening systems like those used in small-scale gold mining operations.⁷ This system was directly connected to two 6-inch-diameter airlifts. The sluice-boxes allowed for the recovery on the surface of small artifacts, leaving the excavators free to concentrate on the recovery of larger items. This system was extremely effective and resulted in almost one hundred percent recovery from the excavated areas. Items as small as straight pins and the gold hands of a pocket watch were trapped by the riffle bars of the sluice. The only drawback with this system was that some items would become trapped in the airlift hose, often not being dislodged until later during the excavation of other areas of the site, again confusing the archeological record.⁸

The grid system used in 1985 was also upgraded over the previous year's grid. Using *DeBraak's* keelson as the baseline, a system of interlocking 6-by-4-foot grid units was laid out over portions of the site which were being excavated. Once a unit was completed the grids could be moved to another part of the site. The grid units were given a trinomial identification code

DeBraak Site Map of 1985 Season Updated and Redrawn from 1984 Base Map

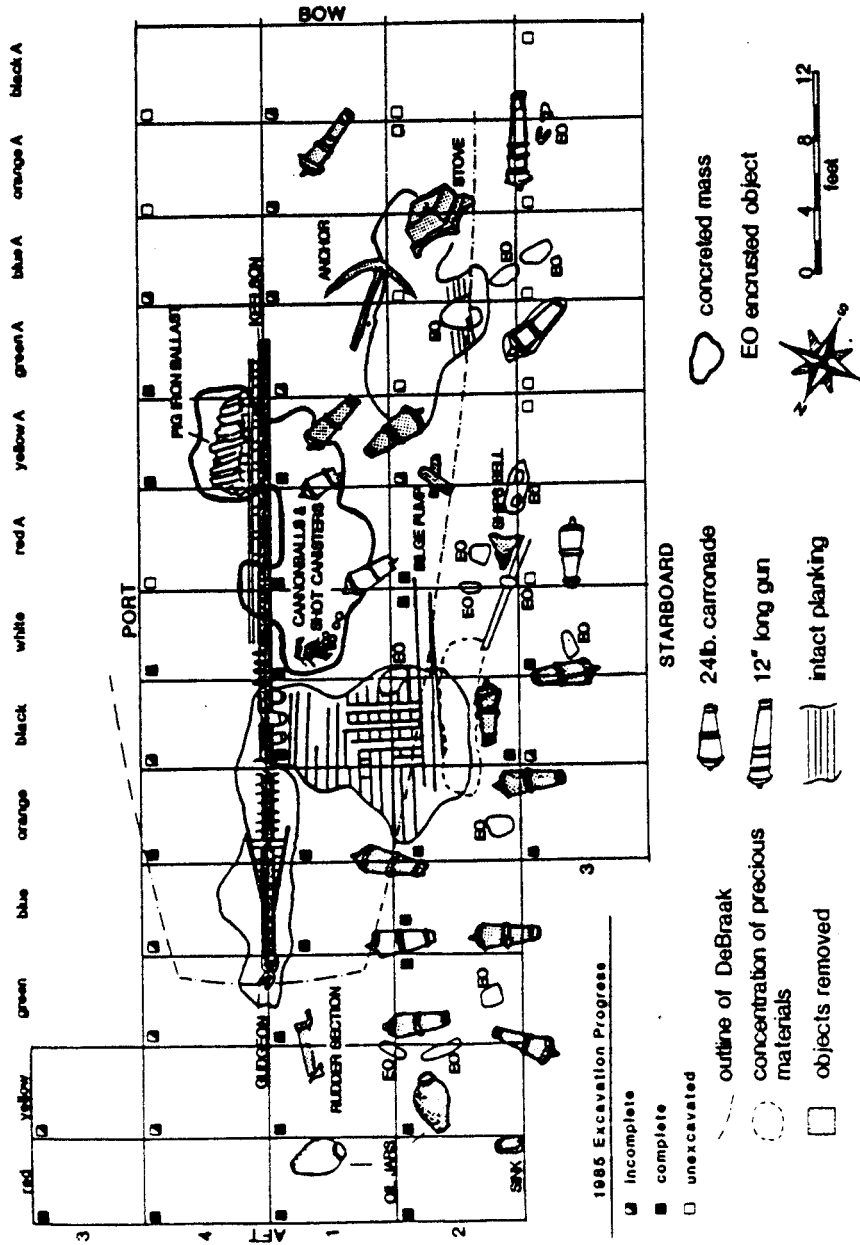

FIGURE 5

using a color, number and letter (i.e. Red 1A) (Fig. 5). This grid allowed for horizontal control of artifact recovery, but not vertical provenience.⁹

The major drawback to the 1985 offshore monitoring operations was the fact that the state had no way of independently verifying the activities of the salvage divers on the wreck. None of the UDCAR personnel were certified divers, nor had they any experience dealing with shipwreck information. To alleviate this flaw and to ensure even better control of data recovery from the site, the state contracted with the author in early December to act as its principal off-shore representative and to work with Reedy in mapping the site. Unfortunately, diving operations were suspended in mid-December before this new offshore policy could be fully implemented.

One of the principal impediments to excavation of the site had been a large concreted mass approximately 25 feet long, 10 feet wide and from 8 to 24 inches thick, which enveloped part of *DeBraak's* hull including the shot lockers. This mass was created by ferrous oxides from the ship's shot, cast-iron ballast, and armament which, when combined with natural sediments and calcareous concretions, formed a cement-like matrix that resisted most methods of reduction available to the salvors and acceptable to the state. Most frustrating to the salvors was the fact that several boxes or crates were encountered within this mass. Although none of those that were broken into contained gold or silver, the salvors were convinced that the "mother lode" they sought lay entombed in the core of this mass.

A meeting was called during mid-December of 1985 to discuss the status of the salvage operations and various means of reducing the concreted mass.

Present at this meeting were representatives of both the State and Sub-Sal, and two outside archeological consultants (John Broadwater of the Virginia Historic Landmarks Commission and Director of the Yorktown Shipwreck Archeological Project, and Walter Zacharchuk, formerly the director of underwater archeology for Parks Canada and at that time a consultant to Treasure Salvors, Inc. of Key West, Florida). Broadwater had made one exploratory dive on the wreck to examine the mass.

At this meeting the idea of using controlled or "surgical" explosive charges to break up the mass was broached. Previous requests by the salvors to use explosives on the site had been refused, but this had apparently been done secretly at least once in 1984.¹⁰ It was determined that in light of new information about the nature of the site in general and the mass in particular this technique would be acceptable to the state if it were used in a controlled manner, and with the understanding that it would be discontinued if the results were detrimental to the archeological integrity of the site to an excessive extent. Also during this meeting a subject arose that would alter the course of *DeBraak's* salvage and ultimately led to the disastrous results, which will be discussed in more detail later.

While discussing the concreted mass and where inside it the treasure might be, Zacharchuk proposed an alternate theory. He claimed it was his experience with ships carrying quantities of coins and bullion that these materials migrated down through the matrix of a site and became lodged beneath the hulls. Gravity accounted for the downward migration of these objects, but he was not specific as to the mechanics of the lateral movement. The chief executive officer of Sub-Sal, L. John Davidson, a Laconia, New

Hampshire real estate developer, was immediately convinced that this was where *DeBraak's* treasure had gone.¹¹ It would explain why so little gold and silver had been recovered during two seasons of salvage operations. The suggestion by state representatives that large quantities of these materials were absent from the site, as indicated by the documentary record, was dismissed without consideration by Davidson.

Discussions then shifted to the topic of ways to efficiently (and economically) recover the treasure from beneath *DeBraak's* hull. The idea that salvage company officials finally decided upon, but to which state representatives were totally opposed, was to use a barge-mounted crane to lift the hull from the site, place it to one side, and then excavate the area with a clamshell bucket. Once again the specter of heavy machinery and destruction loomed above the ill-fated *DeBraak*.

More meetings were held during the late winter and early spring to determine the methodology which Sub-Sal would use in their quest to recover *DeBraak's* fabled treasure. The final agreement consisted of a seven-phase operation:

1. Excavation around the hull with a clamshell.
2. Running lifting slings/cables under the hull.
3. Lifting the hull onto a specially built cradle.
4. Lifting the cradle and hull and place them on a barge.
5. Excavating the site with a fifteen-cubic-yard clamshell.
6. Sifting the bottom sediments to separate treasure and artifacts.
7. Excavation within the recovered hull would be carried out by state archeologists.¹² (See Appendix B for documentation of agreement)

Such a drastic shift in methodology was opposed by all of the state's representatives who were directly involved with historic preservation matters. These low-level state bureaucrats, however, received little support from representatives of the state's administration, such as the Secretary of State's office and the Attorney General's office. Without this support, the historic preservation officials were forced into agreeing with a salvage methodology which could (and in fact did) have a disastrous effect on the archeological integrity of the wreck site.

In preparation for these operations, which were scheduled to begin in early June 1986, Sub-Sal began resurveying the site in mid-March. An intensive visual survey was conducted over the entire wreck site and out to a 100-foot radius from the center of the extant hull remains. The site was then cleared of all old travel lines and shattered PVC grids. The grids had been destroyed when *Sea Star's* anchor was dragged across the site during a severe storm in the last days of the 1985 diving operations. Several previously undetected features of the site were encountered during this survey, including two large iron rings which will be discussed later.¹³

Once this survey of the site was complete the salvors carried out video documentation of all exposed features of the wreck. Due to the poor quality of the hard-wire video system used and the divers' unfamiliarity with ship construction and related artifacts, these video tapes, both visually and narratively, are generally of little use in reconstructing the site.¹⁴

These surveys were suspended in mid-April in order to prepare for full-scale summer salvage operations. It was determined that the state's contracted nautical archeologist would be better qualified than the salvage

divers to map *DeBraak's* wreck site. An accurate site map was something the salvage lease had required, but which the salvors had not produced. An agreement was negotiated wherein the salvage company would provide one of its divers on a regular basis to assist in this mapping operation, so long as it did not interfere with their operations.

Diving operations resumed on June 12, 1986 and preliminary work for lifting the hull was begun. The first step in these operations was to remove sterile (non-artifact-bearing) overburden from *DeBraak's* remains and to fully expose the perimeter of the articulated ship fabric. This was accomplished with a high-pressure water jet attached to a diesel powered pump mounted aboard *R/V Senaca*, a 37-foot-long steel hulled fishing boat used by Sub-Sal for all scuba diving operations. Jetting was halted when concentrations of artifacts or articulated hull was encountered.¹⁵

Once the perimeter of *DeBraak's* articulated hull fabric was determined, high visibility steel pipes, painted with white marine paint, were driven into the ocean floor five feet outboard from the edges and spaced every ten feet around the hull. These pipes were to be used as guides for the clamshell bucket's excavation around the hull. Fortunately, an alternate method was used for this purpose.¹⁶

Seven trenches were then excavated perpendicular to the hull along the port side with hydro-dredges. These trenches were dug deep enough to expose the bottom of the keel and the lowest point of the hull planking. A 1-inch-diameter flexible water probe was then used to pass messenger cables under the hull. These messenger cables were later used to pull the 1-1/2-inch lifting cables into place.¹⁷

Also during this time mapping of the site was begun. This operation had been put off until the maximum amount of hull fabric was exposed. This procedure and its results will be discussed in Chapter V.

With the preliminary work accomplished, a 300-ton-capacity barge-mounted crane was moved into place over *DeBraak's* wreck site on August 4. The "lift," as it had come to be known, was scheduled for the eleventh. In order to make the most of the press coverage, Sub-Sal hired a professional public relations firm to send out press packets and generally to promote the project as the media event of the season.

The crane with its 15-cubic-yard clamshell, dubbed "Jaws" by the archeologists on the project, took its first experimental "bites" from the site on August 5. As agreed upon in the lease, no digging was to be carried out within 20 feet of the hull prior to its being removed from the site. It is fortunate that the preliminary excavation around *DeBraak's* hull was carried out with diver-operated hydro-dredges instead of the clamshell as originally planned, because on August 7 while digging "20 feet" off the stern of the wreck the clamshell brought up the ship's sternpost along with part of the keel. These structural members had been firmly attached to the rest of the extant hull prior to this event. There can be little doubt that had the salvors used the clamshell to excavate around the hull as originally planned, the hull would have suffered far greater damage than it did during the lift.¹⁸

After the first test "bites" it became clear to the salvors that they had grossly misjudged their ability to screen sediment in the quantities being generated by the dredging operation. For that purpose they had constructed

two 4- by 10-foot screening platforms with 1/4-inch mesh screen. The first full bucket to be deposited on one of these screens caused its legs to buckle and sent the assembled personnel scrambling for cover as the clamshell careened madly about the deck of the spoil barge.

Once again it was Zacharchuk who devised the needed technology. His solution: a modified gravel separator rigged with a high-pressure sprinkler and two-stage conveyor belt system through which the dredge spoil could be "processed" in order to retrieve artifacts. After some minor adjustments this system was put into operation and began processing some twenty tons of sediment per day. This operation was initially carried out on board a grounded barge dubbed "Devil's Island," but was later moved into a large warehouse located on the same property for use as the salvor's office and storage facility.¹⁹

Divers were sent down throughout the morning of August 11 to rig the lifting cables to the crane's main cable and lifting blocks. Once all of the cables were in place on the hook, it was decided to put full tension on the rigging to see if it would hold. After this was done, another diver was sent down to check the rigging. He reported that the ring shackled to the forward-most cable had pushed its mousing loose and slipped off the hook. The efforts of two more divers working consecutively failed to correct this problem.²⁰

The scheduled lift time of 2:30 p.m. came and went while attempts were being made to correct the problems with the cables. As the day progressed and the crowds on the beaches and the assembled flotilla of pleasure craft began to dwindle, Sub-Sal officials began to state that the cradle was all

wrong, that it was in the wrong place and had been damaged while it was being placed on the site. The fact that the cradle had been fine in the morning and that a 300-ton-capacity crane and a team of divers who were top notch underwater riggers were standing by to correct any such problems did not deter these officials from their new story. It was apparent that with all of the media coverage and spectators standing by the salvors had no intention of postponing the lift until these engineering problems could be corrected.²¹

The salvors then decided that they would lift *DeBraak* using only the cables at the next slack tide. Davidson conferred with state representatives, who voiced concerns that the cables would inevitably cut into the hull, and who also pointed out that this change in procedures was a blatant violation of the lease agreement. When Dr. John Kern, director of the Delaware Division of Historical and Cultural Affairs, pointed out that Davidson had signed this agreement and that it was legally binding, the chief executive of Sub-Sal replied that he had not signed anything; his lawyers had signed the lease. It was obvious to Kern, a political appointee, that if he tried to interfere with the salvage operations, Davidson, a major supporter of the Republican Party in New Hampshire and more recently of former Delaware Governor Pierre DuPont's bid for the presidency of the United States, would use his influence with the state's administration, also Republican, to see that Kern was stifled, if not fired.

Kern backed down after this confrontation and shortly thereafter fled the barge on the first boat that was going back to shore. Without the support of the director or his superiors, other state historic preservation

representatives on the site were unable to influence the salvors to abandon the only course of action they would consider.

In an attempt to protect the hull from being sliced by the cables, a diver was sent down to place 4"x4"x3' timbers weighted with sections of iron pipe between the starboard edge of the hull and the cables. These weighted timbers, which were held in place by gravity alone, were expected to cushion the effects of a load estimated to weigh in excess of 100 tons.²²

At 8:30 that evening the next slack tide arrived. The crane was made ready and the lift began. Within five minutes *DeBraak's* keel broke the surface, considerably faster than the 1-1/2 feet per minute originally planned. As soon as the hull began to rise out of the water, one of the friction brakes on the crane broke. While the hull hung suspended just below the surface, barge personnel worked to repair the crane. This took almost forty-five minutes, during which time the hull was being further damaged by the cables, and its entire artifact-bearing sediment load was dropped to the ocean floor.²³

Shortly before 9:00 p.m. the brake on the crane was repaired and *DeBraak* was lifted clear of the water, where it hung suspended waiting for a tug to pull the barge into place. During this time it was possible to see how much damage had been done to the hull. Without the support of the cradle, the hull had rolled in the lifting cables until the port side faced up. This allowed the cables to cut deeply into the starboard side by following the inherent weakness between the frames. Virtually all of the artifact-bearing sediment had fallen from the hull. This matrix constituted the primary

cultural deposit and therefore had the greatest potential for yielding unique archeological data.²⁴

Most of the interior partitions had also fallen out with the sediment. These structures would have been of particular interest to maritime archeologists, historians, and ship architects because they were constructed by carpenters after the rest of the ship had been built and therefore appear on no archival plans available for *DeBraak*. When these timbers were later recovered with the clamshell bucket most of them were crushed and twisted, making reattachment with the hull almost impossible.²⁵

While being lowered to the deck of the barge, *DeBraak's* hull received more needless damage. Due to fairly heavy swells offshore, the barge was continuously rising and falling while being towed into place. Poor timing by the crane operator and the already weakened condition of the timbers resulted in a longitudinal crack being made down the length of the hull, approximately 10 feet inboard from the starboard edge, when a large swell rapidly raised the barge, accelerating the force of the impact at the moment it received the hull.²⁶

The structural integrity of the hull was further weakened when the extreme after end of the keel came to rest on several large metal floats which had been left on the barge. The resulting stress caused the keel and deadwoods to crack about twelve feet forward of where the sternpost used to be as the rest of the hull settled unsupported to the deck of the barge.²⁷

The barge carrying the hull was then transported to a pier behind the Sub-Sal offices where it began to be continuously sprinkled with sea water to keep it wet until it could be moved to a more stable and controlled storage

facility. The hull was eventually moved into a concrete and cinder block tank filled with fresh water, where it still waits for further documentation and a decision as to its final disposition.

Sub-Sal eventually dredged up and processed over 9000 cubic yards of ocean bottom. With this material came some of the most significant and best preserved artifacts yet recovered from the site. Tragically, many of these fragile artifacts were damaged, some irreparably, by the dredging, transport and sifting of the soil matrix. Offshore operations were suspended in early December, 1986. Processing and reprocessing of the sediment continued for several more weeks.²⁸

For their efforts and investments Sub-Sal recovered fewer than six hundred gold and silver coins, as well as some jewelry, worth an estimated maximum of four hundred thousand dollars, and what is probably one of the most impressive collections of late-eighteenth century British naval artifacts ever recovered from a shipwreck. They have also received world-wide condemnation by marine archeologists, historians, historic preservation groups, and even other commercial salvors for engaging in one of the worst modern salvages of an historically significant shipwreck in the last twenty-five years. As far as well-publicized salvage operations go, the outright destruction of significant archeological and architectural data is surpassed only by the almost total mutilation of the Civil War Union ironclad river gunboat *Cairo* raised from the Yazoo River in Mississippi in 1964.

Probably the greatest tragedy of *DeBraak's* salvage is that the senseless destruction of this valuable cultural resource need not have happened. The

state of Delaware could have enforced the lease agreement and required the salvors to follow the planned lifting procedures.

Since the end of the salvage operations on *DeBraak's* wreck site in December of 1986, the Delaware Division of Historical and Cultural Affairs has contracted with a number of specialists, including the author, to study the ship and her associated artifacts. Although the results of these studies are beginning to shed much light on the material cultural and shipboard life in the Royal Navy during the last quarter of the eighteenth century, they can never replace the lost archeological data or repair the precious artifacts damaged or destroyed during the salvage operations.

ENDNOTES

¹H. Henry Ward, David V. Beard and Claudia F. Melson, "Preliminary Report on Archaeological Monitoring of the Salvage Activities on the H.M.S. *DeBraak*, 1985," (Unpublished report printed by the University of Delaware Center of Archaeological Research, February, 1986).

²Ward, et. al., "Archaeological Monitoring," 1986, p. 13.

³Ward, et. al., "Archaeological Monitoring," 1986, p. 14.

⁴Ward, et. al., "Archaeological Monitoring," 1986, pp. 14-15.

⁵Ward, et. al., "Archaeological Monitoring," 1986, p. 15.

⁶Ward, et. al., "Archaeological Monitoring," 1986, pp. 17-19.

⁷Ward, et. al., "Archaeological Monitoring," 1986, p. 19.

⁸Ward, et. al., "Archaeological Monitoring," 1986, pp. 31-33.

⁹Ward, et. al., "Archaeological Monitoring," 1986, pp. 26-30.

¹⁰Ronald Marshall, personal communication. Mr. Marshall was involved in the salvage operations during 1984 and is currently writing a book about shipwreck salvage and how people are duped into investing in these operations which rarely make a profit.

¹¹David V. Beard, "The *DeBraak* Recovery Project: A Preliminary Report on Summer-Fall, 1986 Operations," (Unpublished report prepared for the Delaware Division of Historical and Cultural Affairs, April, 1987), p. 4.

¹²Beard, "1986 Operations," pp. 4 & 29-30.

¹³David V. Beard, "*DeBraak* Recovery Project: Winter Operations, 1986," (Unpublished report prepared for the Delaware Division of Historical and Cultural Affairs, May, 1986), p. 3.

¹⁴Beard, "Winter, 1986," p. 4.

¹⁵Beard, "1986 Operations," p. 8.

¹⁶Beard, "1986 Operations," p. 11.

¹⁷Beard, "1986 Operations," p. 12.

¹⁸Beard, "1986 Operations," p. 8.

¹⁹Beard, "1986 Operations," p. 30.

²⁰Beard, "1986 Operations," p. 12.

²¹Beard, "1986 Operations," p. 12-13.

²²Beard, "1986 Operations," p. 13-14.

²³Beard, "1986 Operations," p. 14.

²⁴Beard, "1986 Operations," p. 14.

²⁵Beard, "1986 Operations," p. 14.

²⁶Beard, "1986 Operations," p. 15.

27Beard, "1986 Operations," p. 15.
28Beard, "1986 Operations," p. 30.

CHAPTER IV

SITE LOCATION AND DESCRIPTION¹

The wreck of H.M.S. *DeBraak* formerly lay approximately one mile east-southeast of the Cape Henlopen lighthouse near the town of Lewes, Sussex County, Delaware (Fig. 6). The wreck lay almost totally buried in bottom sediments in 75 to 80 feet of water along the eastern side of the shipping channel leading into the Delaware Bay. It seems probable that due to high velocity currents associated with the estuary inlet, the site underwent a complex series of siltation and scouring episodes. Data collected at the wreck site seems to confirm this theory. These conditions may have contributed to the protection and superior preservation of the ship and associated artifacts. The fact that Sub-Sal had been successful in locating the wreck when so many other salvage efforts had failed may relate to a relatively recent re-exposure of the wreck.

The vertical stratigraphy of the site was difficult to describe accurately, as there was no attempt on the part of the salvors to excavate the site according to any natural or arbitrary level system. In addition, the complexity of a submerged alluvial environment and the effect that the wreck had on the deposition of bottom sediments, produced an often bewildering variability in the quantity of and relationship between sedimentary layers. The following discussion of site stratigraphy, and the schematic site profile (Fig. 7) are conjectural and based on highly qualitative diver observation.

FIGURE 6

SITE LOCATION

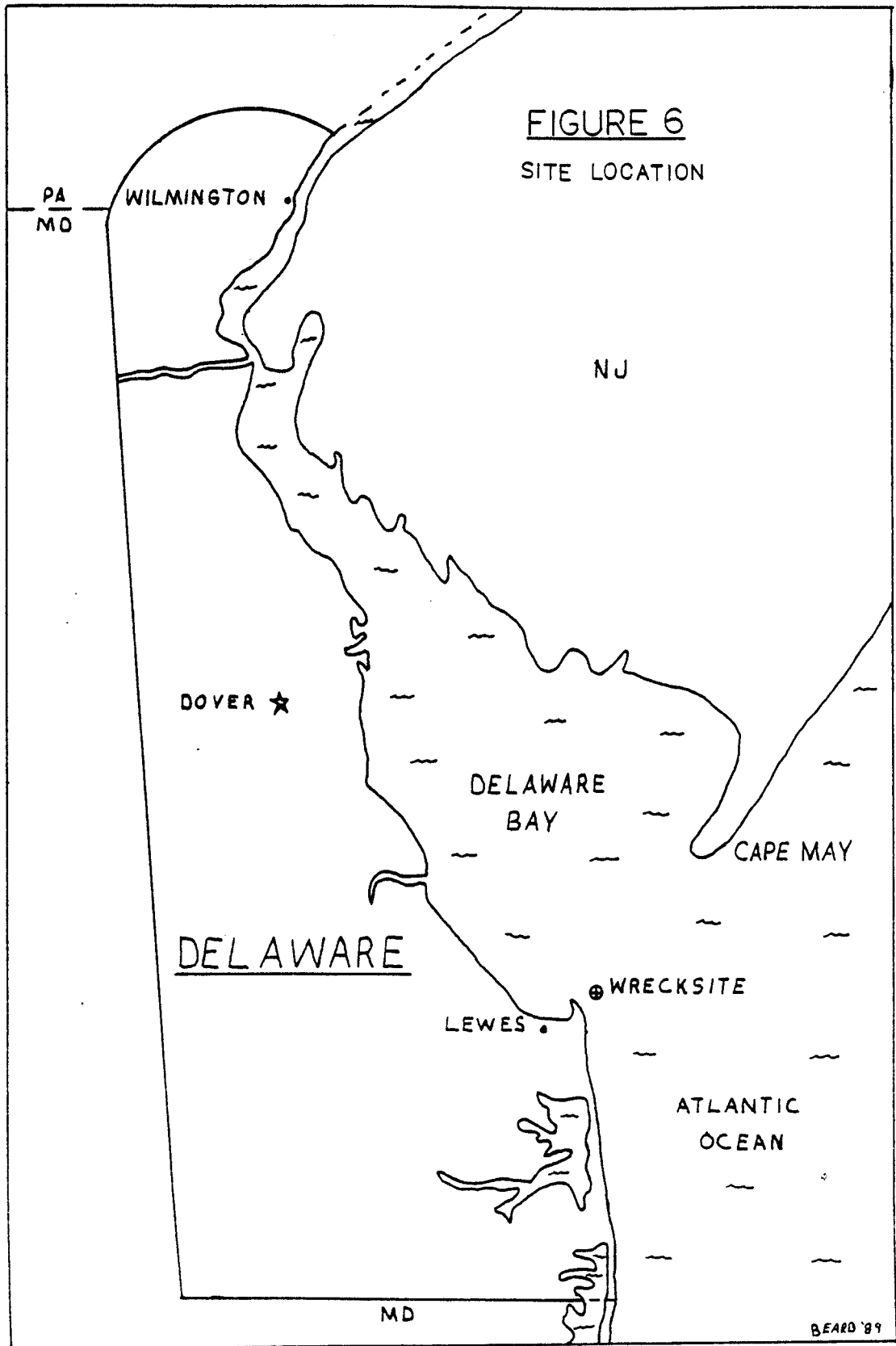

BEARD '89

The sea floor matrix in which the remains of *DeBraak* were buried consists of an upper layer of highly organic dark grey sandy silt mixed with variable concentrations of mussel shell and small gravels (Level A). Below this "muck" layer, as the salvage divers called it, lies a level of greyish sandy clay containing larger cobbles (Level B). Although the deposition history of these upper two layers is unclear, they appear to be of relatively recent deposition, as they appear to have been deposited over the wreck remains. It is the finer silty fractions of these levels that appear to have filled the interior spaces of the ship's hull, resulting in the mucky "soft spots" that were found to contain the best preserved organic remains. The next layer is a thick one of yellow sand, and it is on this (Level C) that the wreck appears to have initially come to rest. Finally, there is a layer of compact yellow sandy clay (Level D), probably of early Holocene age, into which no artifacts seem to have intruded (Fig. 7).²

The environmental conditions at the site make it difficult to carry out diving operations. The wreck's location at the mouth of the Delaware Bay causes the site to be affected by changing tides and offshore currents. During certain phases of the lunar cycle, "new moon" currents up to seven knots have been reported, completely precluding diving. At other times, even the lesser currents significantly hampered the divers' activities and safety. Due to the outflow of the bay and the action of coastal breakers, water turbidity reduced visibility on the site dramatically. Ranging from four feet to zero, visibility averaged less than a foot and a half throughout much of the salvage operation. The exception to this occurred during the

Schematic Cross Section of Wreck Site Indicating Relationship of Wreck Remains With Bottom Sediment Layers

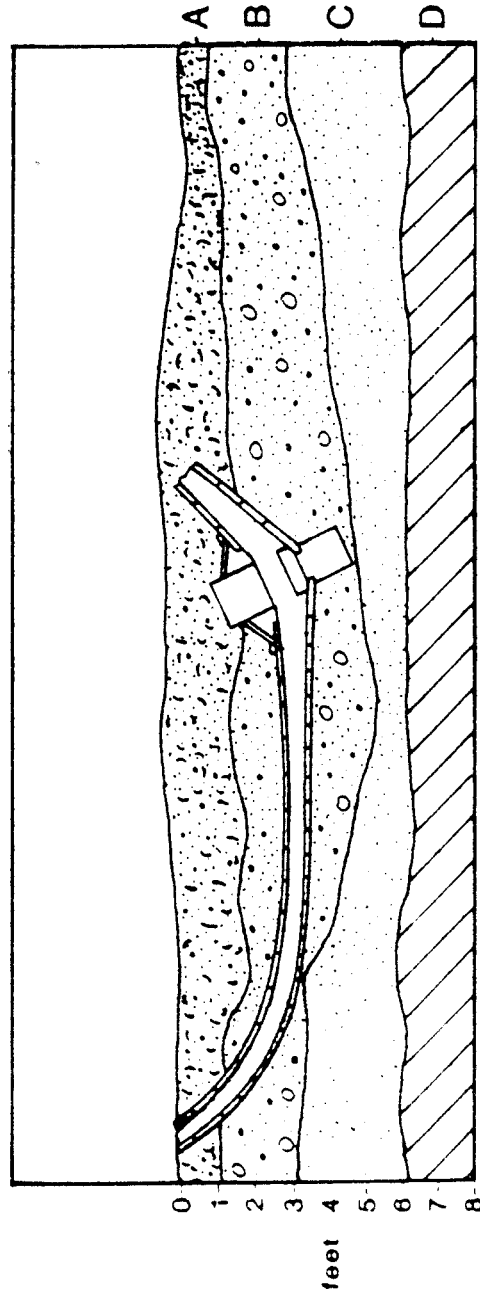

- A "Muck" Layer- highly organic, grey sandy silt with concentrations of mussel shell and small gravels.
Interior of wreck- majority of sediment composed of hull fill.
Exterior of wreck- sediments contain scattered artifacts.
- B "Gravel" Layer- grey sand with larger cobbles.
Interior of wreck- lesser amount of hull fill as A layer.
Exterior of wreck- lesser amount of scattered artifacts than A layer.
- C "Sand" Layer- yellow coarse sand.
Exterior of wreck- few scattered artifacts.
- D "Clay" Layer- compact yellow sandy clay.
No artifacts in this layer.

FIGURE 7

early summer of 1986, when drought conditions decreased the sediment load of the Delaware River considerably, allowing as much as twenty feet of visibility on certain high tides.³

The wreck was oriented northwest to southeast with the bow at 150 degrees (Fig. 8). The best preserved portion of the structural fabric is on the starboard side, as *DeBraak* settled with a list of about thirty-five degrees in that direction. Despite the concentration of most of the cultural material within the wreck mound it was also apparent that artifacts and portions of the ship's fabric had spread over a considerable periphery. This occurred as the ship disintegrated and tidal currents carried materials diagonally out from both sides of the wreck.

Due to the incomplete understanding of the wreck site, it is unclear if this disintegration resulted solely from a gradual decomposition, or a more violent disturbance from subsequent net, anchor or dredge impact. If the existing wreck was the result of a gradual disintegration process, and the data from the site would seem to bear this out, the rate and sequence of the structural collapse may have approximated the model illustrated in Figure 9.⁴ Further filling with sediments would then occur as scouring around the wreck caused it to settle into the seabed, eventually coming to rest on the hard sandy clay of the natural substratum.

Observations made by the author at the site indicated that although a considerable amount of excavation had been carried out on the wreck, most of this had concentrated in and around the stern of the ship in areas where the officers' cabins on the lower deck had collapsed. The remainder of the

FIGURE 9
SIMPLIFIED SITE FORMATION PROCESS

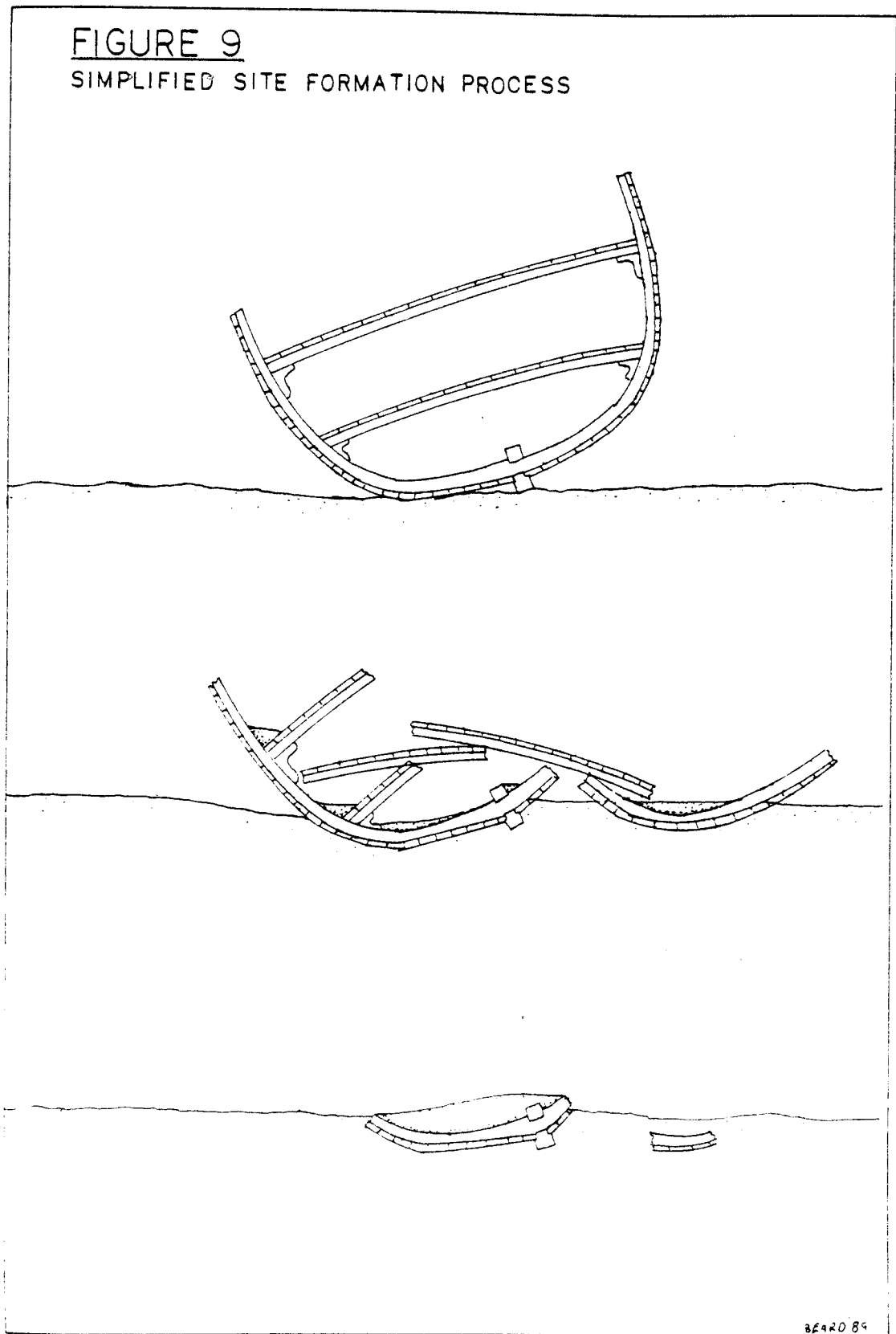

wreck was still relatively undisturbed as of June, 1986. Three pieces of ordnance remained on the site, two carronades and one long gun, and various other large encrustations could be seen exposed in the wreck mound.⁵

Once the relatively sterile overburden had been hydro-jetted from the wreck by salvage divers, it became apparent that the remaining unexcavated portions of the ship contained not only the primary archeological deposit (i.e., the artifacts that had become buried *in-situ* prior to major disintegration of the hull), but also a number of interesting architectural features which do not appear on the Admiralty drafts.⁶ These structures were apparently added to the ship by carpenters after the plans were drawn up, and were most likely intended to support cargo.

Numerous clusters of artifacts had been exposed by the hydro-jet, which helped to identify various stowage areas of the ship. A large number of both long and short sounding leads were still stacked in the area of the bosun's stores. Panes of glass, rolls of lead sheet, and a large, featureless block of wood were located in the area marked on the Admiralty drafts as carpenter's stores. Numerous personal items were also observed indicating that some of the crews' belongings were stored in the lower forward hold. All of these features and concentrations were plotted on the site map (Fig. 8).

One of the most interesting components of the site was a 65-foot-long spar buoy with a large stone anchor and chain, which was sunk along the port side of the wreck. This buoy was made up of several segments rivetted together and had USLHS marked in relief on the top end. These initials stood for the United States Light House Service, which ceased to operate in 1939.⁷

The presence of this buoy on the site has led to some speculation as to how it came to be there. One theory is that the wreck had been marked as an obstruction during the late nineteenth century. This buoy's method of construction points to that period. Secondly, it has been suggested that the buoy became entangled in the wreck while being moved by a powerful storm. The third theory, and the one which made Sub-Sal somewhat uneasy, was that the buoy was used by a previous salvage operation (possibly the 1889 or 1935 expeditions) to mark the site. The location of the buoy's stone anchor less than five feet off the surviving bow of the wreck lent a certain amount of credibility to this theory, but there is no real evidence to substantiate any of the theories.⁸

ENDNOTES

¹Except for minor changes based on data acquired by the author more recently, this section has been taken from a previously compiled report by the author and two colleagues which has already been cited. Ward, et. al. "Archaeological Monitoring," pp. 6-13.

²James Pizzuto, personal communication. Dr. Pizzuto is a professor in the University of Delaware's Department of Geology.

³Beard, "1986 Operations," pp. 5-6.

⁴Alexander McKee, History Under the Sea. (Hutchinson & Co., London, 1968), p.

⁵Beard, "1986 Operations," p. 6-7.

⁶Beard, "1986 Operations," p. 6.

⁷Fred Hopkins, personal communication. Mr. Hopkins is the Provost Marshall at the University of Baltimore and Co-Director of Nautical Archaeological Associates of Upper Marlboro, Maryland.

⁸Beard, "1986 Operations," p. 8-9.

CHAPTER V

METHODOLOGY FOR SITE AND HULL DOCUMENTATION

Underwater Documentation

Documentation of the wreck site of H.M.S. *DeBraak* was begun by the author on June 12, 1986. The first step in this process was to spend six dives surveying the site and becoming familiar with its layout and orientation. Due to severe drought conditions in the region during the previous spring, visibility at the site was excellent during the last half of June and first half of July. Visibility ranged from over twenty feet during certain high tides to five to ten feet at low tide. This allowed much of the mapping to be done without the use of underwater lights. During the last half of July, however, visibility at the site dropped significantly, with the growth of marine organisms such as algae and increased rainfall as the major contributing factors.¹

Since the wreck lay in seventy-five to eighty feet of seawater and all preliminary work was to be carried out with scuba equipment, diving was restricted to slack tides (high and low) during which there was a safe "window" of about thirty to forty minutes when tidal currents were negligible. Phases of the moon affected diving operations. During "new moon" tides there was often little slack tide. Two dives were usually made daily, taking advantage of the daylight slack tides, but occasionally three dives per day were made. This diving schedule allowed for a maximum of forty minutes for the first dive, thirty-two minutes for the second dive and, when possible, twenty-eight minutes for the third dive.²

Sub-Sal had agreed to provide one diver as needed to assist in the documentation of *DeBraak's* wrecksite. It was determined that, considering the limits of a two diver operation, triangulation from a fixed baseline would be the most expedient method for mapping the site. For this purpose an eighty-foot-long polypropylene line was fitted with stainless steel wire "eyes" at ten-foot intervals. Each eye was marked with a numbered piece of duct tape and became stations from which measurements were taken (Fig. 8).³

Initially it was planned to run the baseline straight down the keelson of the wreck, but the shot lockers straddled this timber and stood several feet above it, making this impractical. The baseline was laid diagonally across the hull, with "0" at the inside face of the remaining gudgeon on the sternpost. Then, running just to starboard of the aft end of the shot lockers, the baseline was extended out past the surviving hull fabric of the bow and was anchored in sterile sand (Fig. 8, p. 66).⁴

Prior to taking the triangulated measurements of the site it first had to be determined what minimum number of points were needed in order to record the wreck adequately. Numbered plastic tags were prepared for this purpose and were affixed to the exposed tops of important structural members: every five feet around the perimeter of the hull, the corners of the shot lockers, ends of exposed bulkheads, etc.⁵

The selected points were then measured from two stations on the triangulation line and the data recorded on a specially prepared mylar worksheet. Documentation was begun in the stern and the two plastic tapes (first anchored to 0' and 10') would be advanced along the triangulation line,

in a "leap-frog" fashion, before the forward edge of the triangle became obtuse. This process was continued until the full length of the extant hull was recorded.⁶

Special structural features, such as the shot lockers, mast steps and bulkheads, were not only triangulated, but also drawn to scale in order to record specific details of their construction. Due to the lack of vertical control and the varied relief of the wreck, some of the triangulated measurements were off by several inches and corrections had to be made on the site map using the measured drawings and common sense. Suprisingly, when the site map was compared with the Admiralty drafts of *DeBraak*, many of the structural features recorded in this manner aligned well.⁷

A number of exposed isolated artifacts and artifact concentrations were recorded on the site map. Portable artifacts uncovered by the hydro-jet were triangulated and removed from the site. Artifacts were given grid provenience on the site map using the 1985 grid system. This was accomplished by superimposing a plan of the 1985 grid over the 1986 site map, providing a certain amount of continuity for artifact provenience. These few artifacts shown on the site plan (Fig. 8, p. 66) are the only ones with any provenience from 1986 and have the best provenience of any artifacts recovered from the site during the entire three years of salvage operations.⁸

As has been previously mentioned, the salvors attempted to make a video documentation of the wreck site, with minimal results. During late July 1986 an attempt was made to photograph the site. The lack of any underwater photography equipment on the project had been a major frustration, since in

mid-June the visibility had been good enough to produce a very good photo-mosaic of the site. By the time a diver could be hired to do this photography, visibility on the wreck site had deteriorated to such an extent that the results of this operation were of little use in reconstructing lost structural elements.⁹

Post-recovery Hull Documentation

Immediately following the recovery of *DeBraak's* hull, personnel from the Delaware Division of Historical and Cultural Affairs, under the direction of the author, began frantic efforts to document that incredibly large and complex artifact. At that time there was the very real possibility that the hull would be returned to the site once excavation offshore was complete, so the initial documentation phase focused primarily on detailed photography of the hull with proper scales included. For reference the hull was divided into five arbitrary sections separated by the riders, with the forwardmost section being Section 1 and the after most section past the surviving ceiling planking being Section 5.¹⁰

Surprisingly, much of the ship's cast iron ballast remained concreted to the ceiling planking. Also, many of the 24-pounder solid shot in the shot lockers remained *in-situ* the heavy concretion acting like cement in keeping the lockers themselves from becoming totally separated from the hull during the recovery. These artifacts were photographed (scale drawings of the ballast were also made) and removed from the hull.¹¹

When it became apparent that the hull was not going to be replaced on the site, the documentation strategy changed to one of producing one-to-one

scale tracings of the ceiling planking, shot locker components, keelson, and various pieces of disarticulated hull fabric and making measured drawings of timbers not suitable for tracing. However, most of the remainder of the fall of 1986 was spent in the physical maintenance of the hull, including moving it from the barge to its storage tank and flushing sediment from between the frames.

It was found that the quickest, as well as the most accurate, way to record the details of the ceiling planking was to trace them. This consisted of pinning large sheets of frosted mylar to the ceiling planking, using the side of the keelson as the baseline, and then tracing the details with water-resistant "China Markers." Black was used for plank seams and other timbers, blue for copper drift pins and spikes, green for trunnels, and red for iron spikes and nails (holes only remained of the latter). These tracings were made so as to overlap, allowing the recorders to use manageable sized sheets of mylar for later reduction.¹²

The next step was to take the rough mylar tracings, wash and dry them, and then re-trace the data on clean poly-vinyl acetate (clear plastic sheeting) using permanent "Sharpie" markers of the same colors as the "China Markers." During this stage of the process, lines were made sharper and complete (the China Markers did not always take on the mylar), drift pins and trunnels were made rounder and spikes were transformed from smeared circles into squares.

The working scale for most drawings relating to ship construction was 1 inch equals 1 foot. This scale allowed for a manageable sized drawing of the hull (a little over 70 inches in length) without losing too much detail under

the pencil lines. In order to reduce the full-size tracings down to the working scale, a special mylar sheet, slightly larger than the tracings, was prepared with a grid made up of 3 inch squares. The grid squares on the mylar matched the 1/4 inch grid paper used for the reduced drawings. With a minimal amount of additional measuring the tracings could be transferred to scale drawings with little loss of detail.

The individual drawings were then connected to form complete sections of ceiling planking which was broken into arbitrary sections by the riders. To graphically illustrate the ceiling planking without the distortion of its three-dimensional nature, a two-dimensional "expansion" was produced (See Figure 29 in Chapter VI). Although not absolutely accurate, this method illustrates very well the "run" of the planking, including the use of stealers in the bow and stern to compensate for the curvature of the hull.

This system of tracing also worked well in helping to reconstruct structural features such as bulkheads which fell out of the hull during its recovery. Various pieces of bulkhead planking, with their distinct ship-lap rabbeting, were traced and reduced. Photocopies were made and cut out, making for something akin to a jig-saw puzzle. By this method the author was able to reconstruct a small section of the forward bulkhead (See Figure 44 in Chapter VI).

The major timbers which formed the backbone of the ship (keel, stem assembly, stern assembly, floors, deadwoods, and keelson) were recorded in a less complicated manner. These timbers were recorded by their sided and molded dimensions, using plastic tapes and carpenters' squares, and immediately turned into scale drawings. The very strong and tightly framed

construction of *DeBraak* made acquisition of much of this data extremely difficult, if not impossible in some cases, so some of the graphic illustrations are based on conjecture and "best guess" common sense or simply by extending an unseen line to its likely terminus. Such was the case with both the hog above the keel and a long wedge shaped timber above the hog which extended from several feet aft of the mainmast step to an undetermined point approximately midway along the keel (See Figure 18 in Chapter VI).

Several cross-sections of the hull were also produced. Due to the distortion of the hull caused by the damage received during its recovery, it was impossible to determine the actual curvature at any given point using methods such as level and plumb lines. Since the purpose of the cross-sections was to illustrate gross architectural features and not to produce hull lines, it was determined that best solution to this problem was to reproduce the lines of the hull at the desired location as indicated on *DeBraak's* Admiralty drafts. The outside hull section was then drawn incorporating the actual keel dimensions. To this drawing were added the molded and sided dimensions of the hog and other deadwoods, the molded dimension of the floors at that point, and the molded and sided dimensions of the keelson. A plastic tape was then laid out along the desired section line on the surviving hull, following the contour of the ceiling. The seams of planking were recorded along this curved line. These measurements were then transposed onto a graduated flexible curve which was used to plot plank seams on the drawings, using an inch equals one foot scale. During this process the thickness of the planks and the estimated reduction in the molded

dimensions of the frames from the keel to the surviving outboard ends had to be taken into consideration (See Figures 33, 35 & 36 in Chapter VI).

Special structural features such as mast steps, riders, hanging knees, and remnants of dowels for riding bitts and the bowsprit step were recorded separately, in both plan and section views, and incorporated into the appropriate cross-section when possible. Plan views of the mast steps in particular are incorporated into the graphics of hull cross-sections (See Figures 33, 35 & 36 in Chapter VI).

The sided and molded dimensions of and the spaces between the frames were recorded within arbitrary hull sections divided by riders. Data was recorded noting which ones were floors, first futtocks and filling frames. Due to the close spacing of the floors in some areas or the obstruction caused by the riders and mast steps some of this data was unattainable. Space permitting, a 1/2-inch-diameter section of PVC pipe was then used as a probe to locate the distal ends of futtocks. This process was only moderately successful.

As a final step in the preliminary documentation of *DeBraak's* hull another session of detailed photography was initiated. This phase included the first complete plan-view photographs (Fig. 10), taken from the bucket of the Lewes, Delaware Volunteer Fire Department's hook and ladder truck, as well as photographs of various pieces of ship's fabric which had been rearticulated with the hull.



ENDNOTES

- 1Beard, "1986 Operations."
- 2Coleman, J.J., U.S. Navy Air Decompression Table Handbook, (Navy Department: Washington, D.C., 1974), pp. 22-45.
- 3Beard, "1986 Operations," p. 6.
- 4Beard, "1986 Operations," p. 6.
- 5Beard, "1986 Operations," p. 6.
- 6Beard, "1986 Operations," p. 6.
- 7Beard, "1986 Operations," pp. 6-7.
- 8Beard, "1986 Operations," p. 6.
- 9Beard, "1986 Operations," p. 7.
- 10Beard, "1986 Operations," pp. 17-18.
- 11Beard, "1986 Operations," p. 18.
- 12Beard, "1986 Operations," p. 19.

CHAPTER VI

ARCHITECTURAL ANALYSIS

Historical Perspective

The hull of H.M.S. *DeBraak* poses several problems for students of eighteenth-century naval architecture. First, the ship was at least twenty years old when she sank and presumably had undergone several refittings. Second, during her career *DeBraak* belonged to three European powers, each of which differed in its approach to shipbuilding. And finally, since many of the interior structures of the ship, such as bulkheads, partitions and decking, fell out of the hull during its salvage, much of the reconstruction of these structures on paper is almost totally conjectural, and is based on fragmentary timbers, impressions, and fastener patterns left by the lost timbers.

The following section of this thesis/site report will focus on the state of the shipwright's art at the time of *DeBraak's* career and how that art manifested itself in this particular ship. Also covered will be a description of what is known about her refitting in 1797 and the results of a detailed study of her hull remains which was carried out from June of 1986 until October of 1988. And finally, there will be the analysis of various fittings associated with the construction and fitting of the hull.

By the last quarter of the eighteenth century, when *DeBraak* was built, English naval architecture, as far as wooden ships were concerned, had almost reached its zenith. Sail, as a viable means of propulsion for military

purposes, would be virtually obsolete within a century and the dawn of the age of iron ships and steam propulsion was only a few decades away.

DeBraak was built during a time when England's navy and naval industries were stretched almost to their limits. Her American colonies were in rebellion and she was once again at war with France and her allies. The logistics of supplying an army across the Atlantic and the protection of commerce with the rest of her global empire required an incredible number of both naval and merchant vessels of all descriptions.

It is not currently known where in England *DeBraak* was built or, for that matter, what she was originally named. As was mentioned in an earlier chapter, the ship was probably built at a private shipyard for the purpose of privateering.¹ That being the case, the builders were not regulated in the specifications for her construction, although data from the hull, such as the keel scarphs, seems to indicate that some attempt was made to follow Admiralty specifications for vessels of that size. It may be that the shipwrights had some experience building small Royal Navy vessels under contract and tried to apply that experience to *DeBraak*.

On the basis of information gathered from the hull it seems that *DeBraak* was constructed mostly from materials commonly used in English shipbuilding. Her keel was made from elm (probably English). Frames, stem and stern posts, deadwoods, the keelson, and hull and ceiling planking were of white oak. English oak was preferred but some may have been procured from the Baltic ports of Stettin, Danzig and Memel. Interior structures such as bulkheads, partitions and shot lockers were constructed from red (Riga?) pine possibly from the area near the Baltic city of Riga at the mouth of the

Duna River.²

One interesting exception to the above is the peculiar wedge-shaped piece of rising wood which tops the aft half of the hog (Fig. 18). This timber is made from some species of tropical hardwood, possibly indigenous to Maylasia. It may be that this timber was built into *DeBraak's* (*deBrak's*) hull during an extensive refit while she was on station with the Dutch in the East Indies.³

If *DeBraak* was originally built for privateering, as has been suggested previously, then her purpose was clear: preying on the maritime commerce of England's enemies. Once she was captured by the French and sold to the Dutch, however, her purpose changed; she became a naval vessel.

Vessels of that size were used for a variety of naval duties ranging from dispatch service to convoy and patrol. Not large or heavily armed enough to engage larger warships, these small, fast ships were better suited for carrying messages, reporting on the movements of the enemy and convoying fleets of merchant vessels in order to protect them from the privateers of hostile nations. Upon encountering a larger warship intent on capturing a convoy, these small vessels would be wise to put up a limited resistance and then withdraw, possibly losing the slowest part of the convoy, but saving themselves and the faster merchantmen.

The 1797 Refitting

Before an analysis of *DeBraak's* remaining hull fabric can be carried out, it is important to understand what kind of alterations she underwent during her refit during May and June, 1797. As has been mentioned previously,

Drawn by
City 1917
Wm. Langford

4/3/17

COUNTRY
No. 514
NAME: DE BRASCO
No. 100
No. 100
No. 100

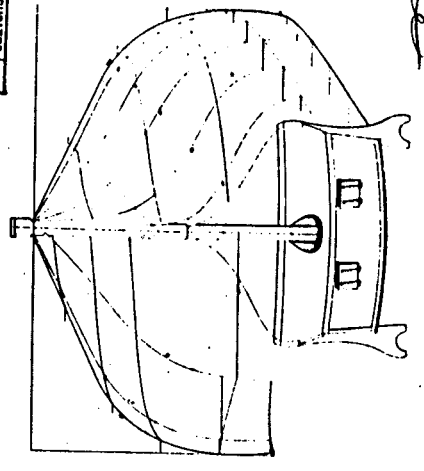
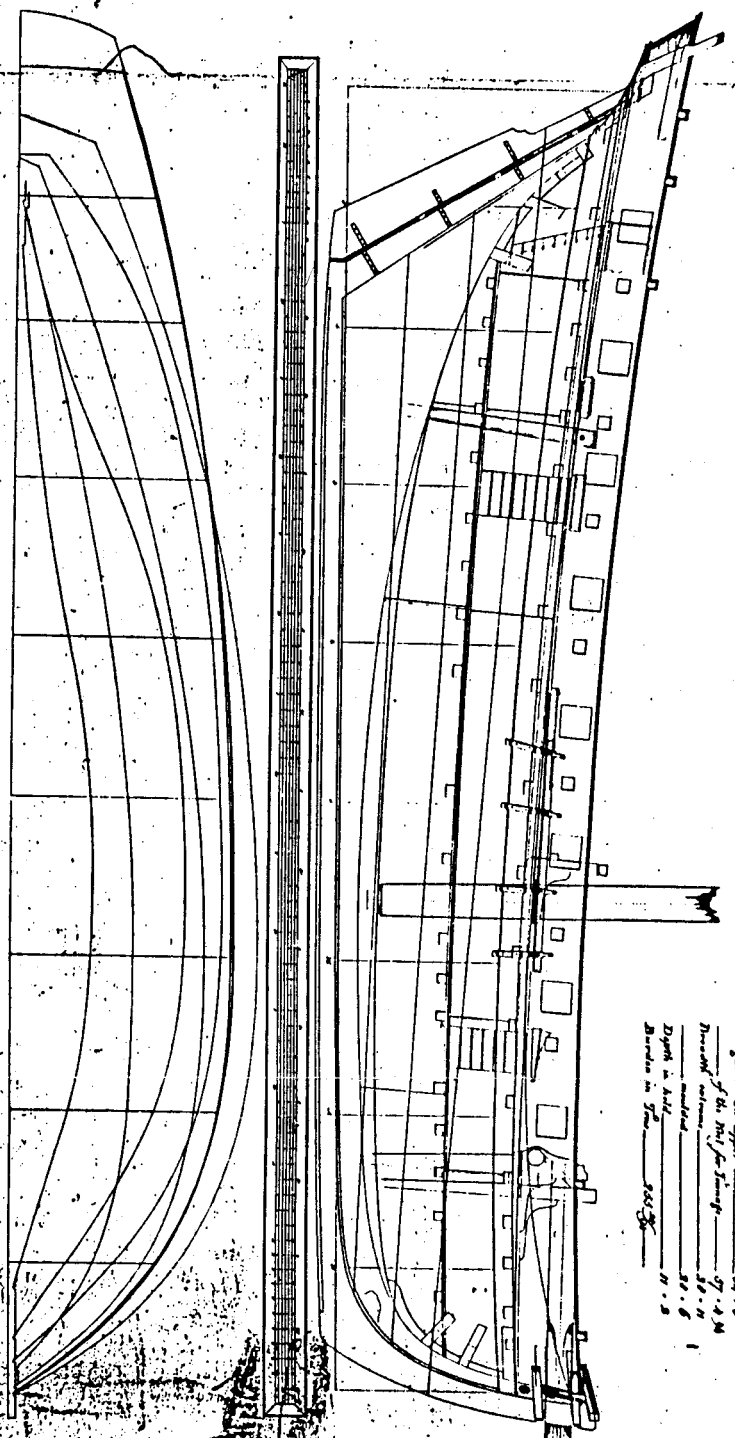

FIGURE II



DE BRASCO - also known as
Length - 46 ft. 0 in.
Breadth - 10 ft. 0 in.
Depth - 4 ft. 0 in.
Displacement - 1000 lbs.

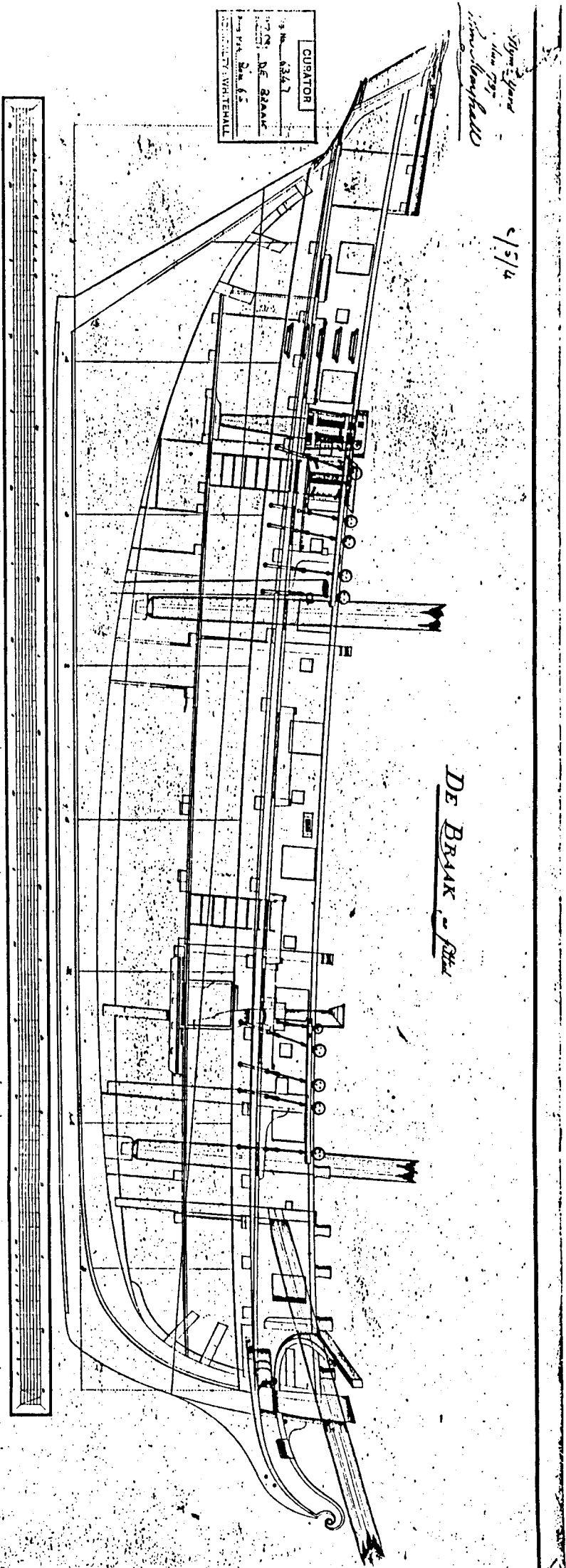

FIGURE 12

*Original from
May 1909
John Marshall*

CUNARD
No. 3387A
DESIGN: D. S. BARR
BY: J. H. BARR
DATE: 1888

PLANS OF DE BRAN at Fitch

Upper Deck

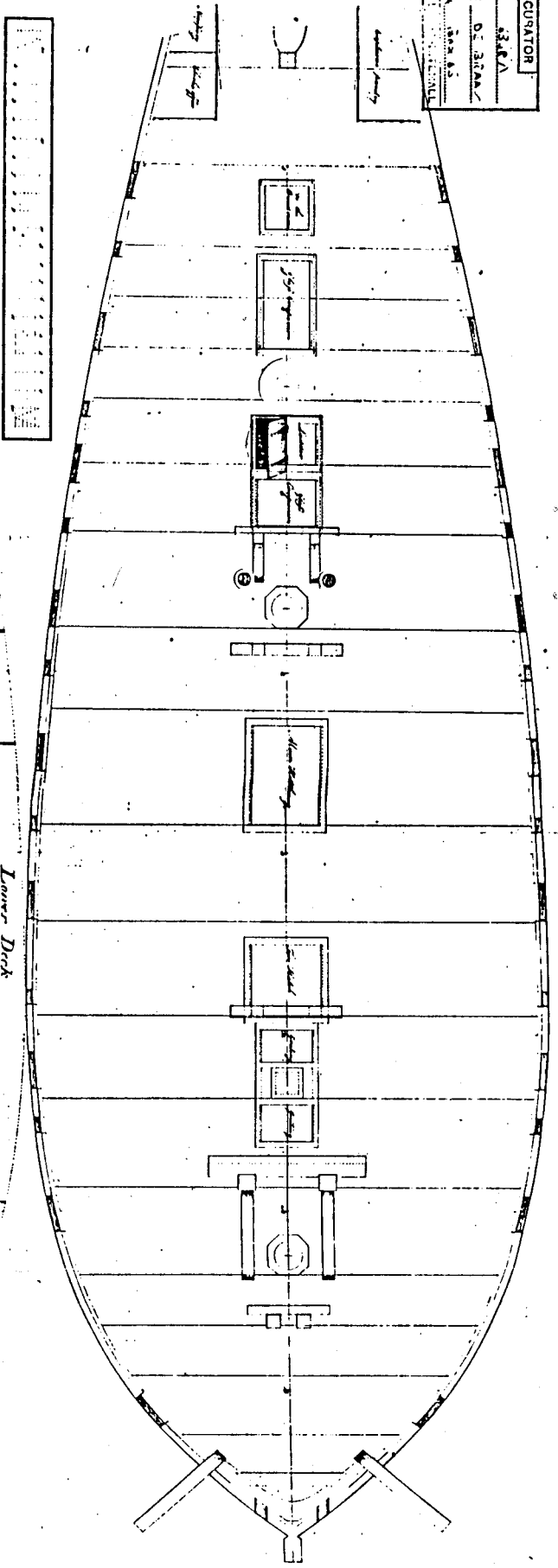

Lower Deck

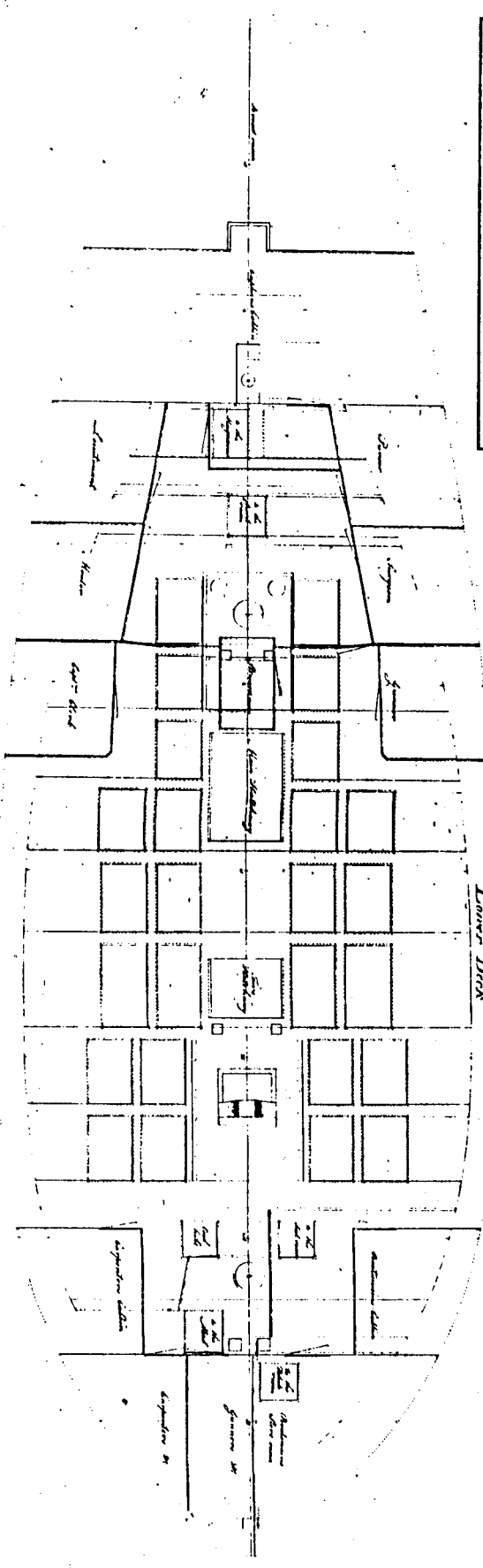

FIGURE 13

DeBraak was a cutter when captured from the Dutch in 1795. It can be reasoned that she had been rigged in this manner since her construction in England between the late 1770's and 1781, when she was captured by the French and then subsequently sold to the Dutch.⁴

DeBraak was taken to the Plymouth Dockyard and a survey of the ship was carried out. This survey indicated that *DeBraak* was a vessel of 255 tons burden. She was eighty-four feet long on her upper deck, had a keel length for tonnage of fifty-seven feet, extreme beam of twenty-nine feet and a depth-of-hold of eleven feet. The British decided to convert her into a brig, and it was reported that this operation would take three weeks.⁵ The exact nature of the complete refit is unknown. It is also not currently known how much hull fabric was replaced, because the records relating to survey and repair of vessels at the Plymouth Dockyard were destroyed in World War II.⁶ On the basis of data recovered from the hull (i.e. replaced futtocks and drift pins stamped with the English Broad Arrow), however, it can be inferred that at least some of these timbers were replaced.

Based on the "as when taken" and "as fitted" Admiralty drafts of *DeBraak*, a number of observations as to the extent of the alterations can be made.⁷ The following is a list of observable alterations made during the conversion from a cutter to a brig.

Before *DeBraak* was taken into dry dock for refitting, she presumably was stripped of all of her guns, stores and furnishings. Most of her rigging, including her mast, were also removed. Once the ship was in dry dock, John Marshall, Surveyor of the Navy, drew up a set of plans labeled "as when taken" showing her hull and decks (Fig. 11). Using these plans as a base,

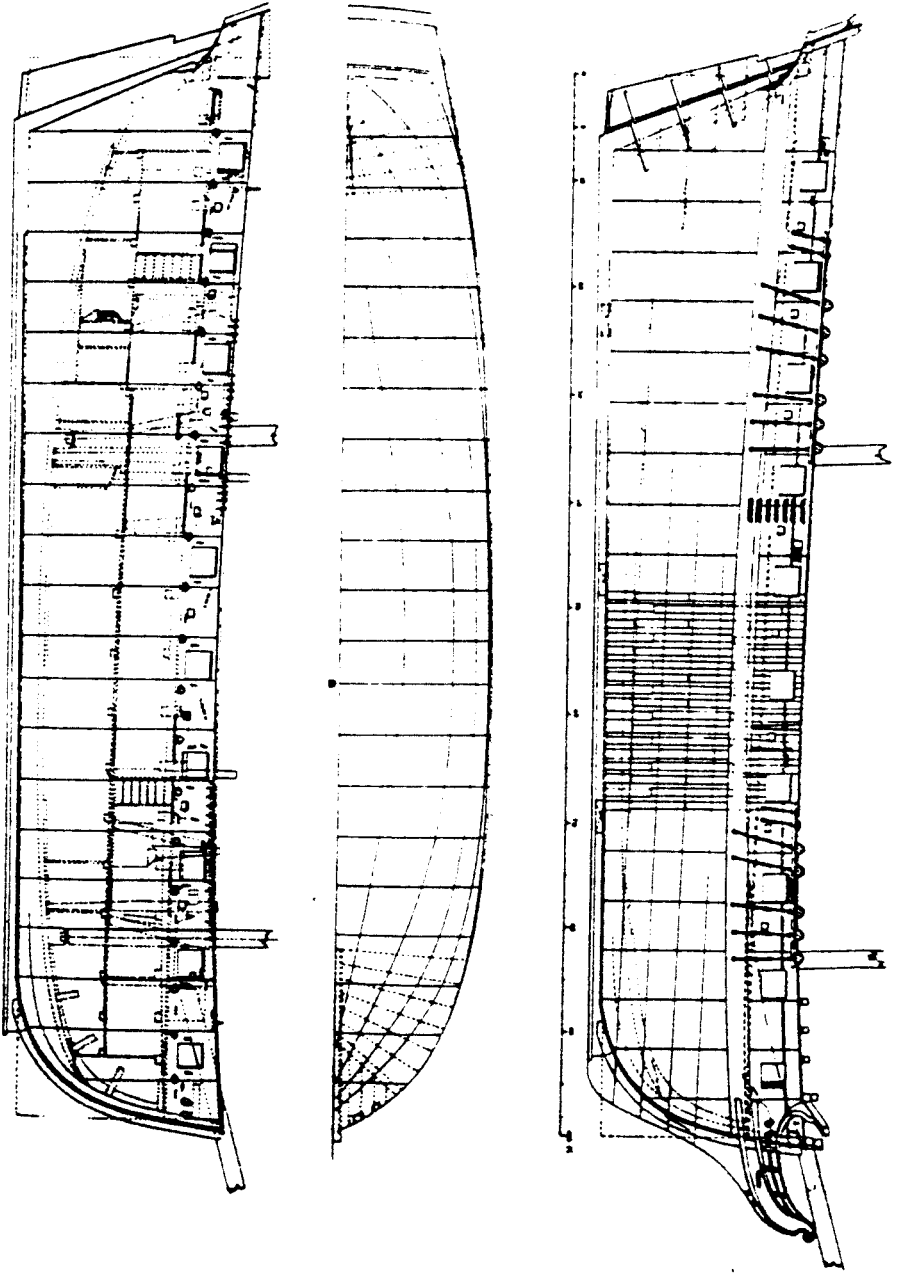
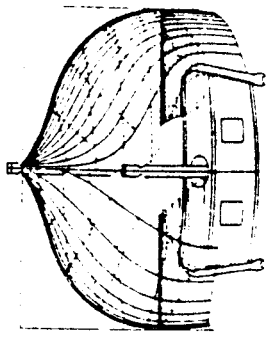

HMS RAVEN, 1797

FIGURE 1A

FROM PROCEEDINGS OF THE ROYAL SOCIETY OF NAVAL ARCHITECTS (1898-99)

Marshal then drew the needed alterations for the ship's conversion into a Royal Navy brig and produced a set of "as fitted" drawings (Figs. 12 & 13). Figure 14 shows the "as built" plans of H.M.S. *Raven*, an eighteen-gun brig of 1797, which gives the reader a good idea of what the shipwrights were trying to accomplish in their conversion of *DeBraak*.⁸

One of the first steps in refitting a ship was to repair or replace damaged and dryrotted timbers. As will be discussed later, this was often a selective and arbitrary process. Once this was done the shipwrights could begin the task of carrying out the extensive alterations and additions needed for the conversion.

The exact order in which these alterations were carried out cannot be known. Beginning in the stern, however, these alterations can be clearly discerned from the plans. Refer to Figures 11 through 13 for graphic illustration of the following information.

As a cutter, *DeBraak* had an even sheer from bow to stern. During the refit, port and starboard cabins were erected on the upper deck in her stern. This entailed raising the gunwales 2 feet, roofing these cabins over and adding skylights. These cabins were 6 feet, 6 inches long. They were 3 feet 6 inches wide at the forward end and tapered toward the stern. The port cabin was to be the captain's pantry while the starboard cabin was divided into the clerk's office (forward) and a necessary, or toilet (aft). This illustrates well the cramped conditions in which *DeBraak's* crew of eighty-five must have existed.

The aft ladderway was removed and replaced with a hatch leading to the breadroom. A glass companion was cut through the upper deck thirteen

inches forward of this hatch to allow light into the lower deck. The shipwrights made use of an existing glass companion through which they installed the capstan. As a cutter *deBrak* used a windlass, located in her bow, instead of a capstan.

The original pumps were removed and a ladderway to the officers' quarters was cut through the deck. A small hood with hinged side and top doors was built over this ladderway. An existing ladderway forward of this was converted into another glass companion. The wooden tubes for the suction pumps were moved forward and let through the deck two and one half feet forward of this companion.

In order to allow placement of the mainmast, the upper deck had to be pierced. This mast, along with the pump tubes, then continued down through an existing hatch in the lower deck and was stepped onto the keelson.

The main hatch was left, but a fore hatch was added, making use of a hole left by the cutter mast. The forward ladderway was enlarged to accommodate the smoke stack for the stove installed in the new galley, as well as two ventilation grates - one forward and one aft of the stack.

The windlass and bowsprit step and posts were removed and the hole they left was enlarged to accept the foremast. The foremast also pierced the lower deck and its step saddled over the keelson. The windlass had been incorporated into the same structure as the bowsprit step for added strength.

The posts for the new bowsprit step were let through both decks, 2 feet, 6 inches forward of the foremast, and stepped into floor timbers on either side

of the keelson. A large timber was bolted to these posts and a cross piece, and was morticed to receive the butt of the bowsprit.

When rigged as a cutter, *deBrak's* bowsprit had been offset to the port side of the ship's centerline. The stive or angle of inclination of the bowsprit was significantly increased. The bowsprit was fastened to a newly added beakhead to withstand the strain caused by the alteration of the headsails.

The arrangement of the lower deck was also changed to a certain extent. Most notable was the addition of cabins for the officers forward of the existing main (captain's) cabin. This consisted of tearing out two large existing cabins (one to port and one to starboard) and replacing them with cabins for the lieutenant, master, and captain's clerk on the starboard side and the purser, surgeon, and gunner on the port side. In the bow two cabins were constructed for the carpenter and boatswain, just aft of the existing carpenter's and boatswain's stores. In the hold a double compartmented shot locker was constructed around the mainmast step.

The cutter sheer plan shows no galley. During the conversion for Royal Navy service a galley was added which included what was probably a "Brodie Patent" cast iron stove.⁹ A special lead-lined recess (firehearth pit?) was built into the lower deck for the stove to be mounted in. This recess may also have been filled with sand, to catch burning cinders and therefore reduce the chance of fire on board the ship (See Fig. 51, p. 148).

Other alterations undoubtedly were made to *DeBraak's* interior, but are not indicated on the Admiralty drafts. Due to the loss of the interior structures it may be impossible to determine the exact nature of these alterations.

Hull Construction Analysis

Analysis of *DeBraak's* remains is limited by several factors. First, only about forty percent of the starboard side and a small fraction of the port side of the vessel remain (Figs. 15 & 28). Second, most of the surviving interior partitions and other structures were lost during the hull's recovery, making much of the on-paper reconstruction conjectural. And, finally, the method in which the hull is supported in its storage tank makes most of the surviving exterior hull inaccessible. Despite these limitations, it has been possible to generate enough data to accurately detail most of the remaining structural composition of the hull, and to reach several educated conclusions concerning the vessel's original form and subsequent structural evolution.

The surviving hull fabric of *DeBraak* includes, but is not limited to, her keel, keelson, some deadwoods, stem components, sternpost, framing components, ceiling and hull planking, riders and knees, mast steps, riding bitt and bowsprit step dowels, shot lockers and various disarticulated interior partitions, rudder sections and associated hardware, and associated fasteners and sheathing. There are also various disarticulated fittings associated with construction of the hull such as scupper pipes, capstan fragments, and objects associated with the galley.

This section of this thesis/site report seeks to analyze all of these structural components and to reach certain conclusions as to their construction and function, and how they relate to the available documentary

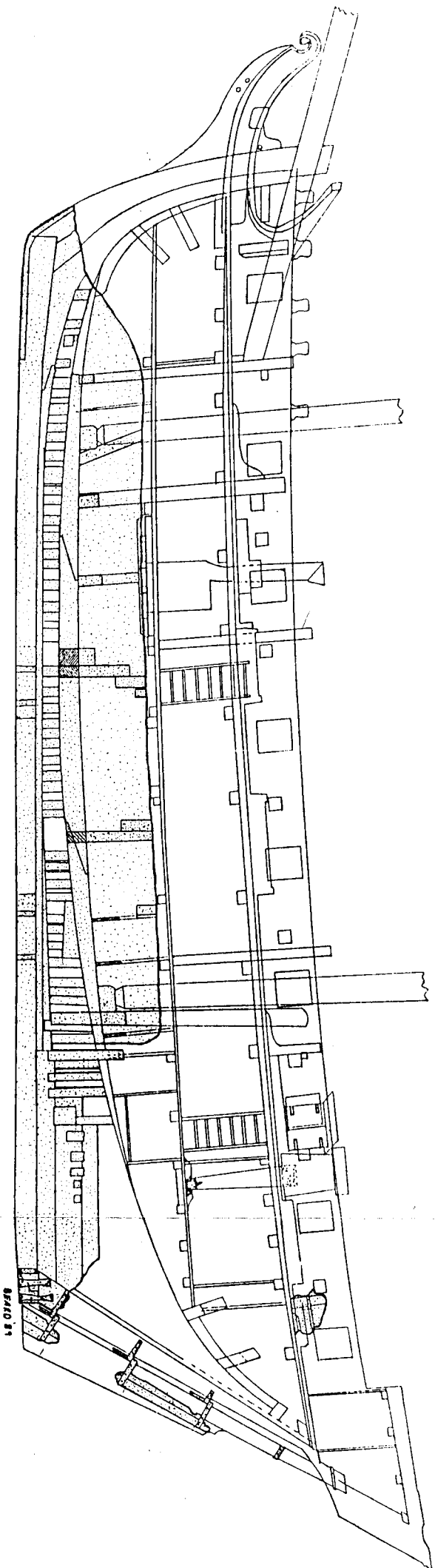

SURVIVING
FABRIC



FIGURE 15

data on ship construction during the last quarter of the eighteenth century. It will not, however, be the last word on *DeBraak's* construction and should be considered preliminary.

Keel

DeBraak's keel is constructed of three baulks (sections) of elm with a total length of 68 feet, 9 inches (Fig. 16). It was considered standard that a ship of *DeBraak's* size should have a keel made up of four baulks.¹⁰ The forwardmost baulk of the keel is 31 feet, 8-1/2 inches long, including the scarph. Both the sided and molded dimensions of this timber vary over its length. At its forward most end this baulk is sided 10 inches and molded 24-1/2 inches.¹¹ At its after end (including the scarph) it is sided 12 inches and molded 13-1/2 inches including the rabbet.

The central baulk of the keel is of generally uniform siding and molding. This timber is 16 feet, 9-3/4 inches long including both scarph joints. It is sided 12 inches and molded 12-1/2 inches.

The aftermost baulk is 26 feet long, including the scarph and like the forward baulk, has varied sided and molded dimensions. Its forward end has the same dimensions as the central baulk, but the sided dimension tapers to just 9 inches at the sternpost where its molded dimension is reduced to 11 inches. The aftermost end of the stern baulk has been repaired at some time. This and other repairs will be discussed in a later section.

The keel baulks are fastened together at two vertical scarph joints, each 4 feet, 6 inches long and having ends nibbed 1-1/4 inches. This dimension

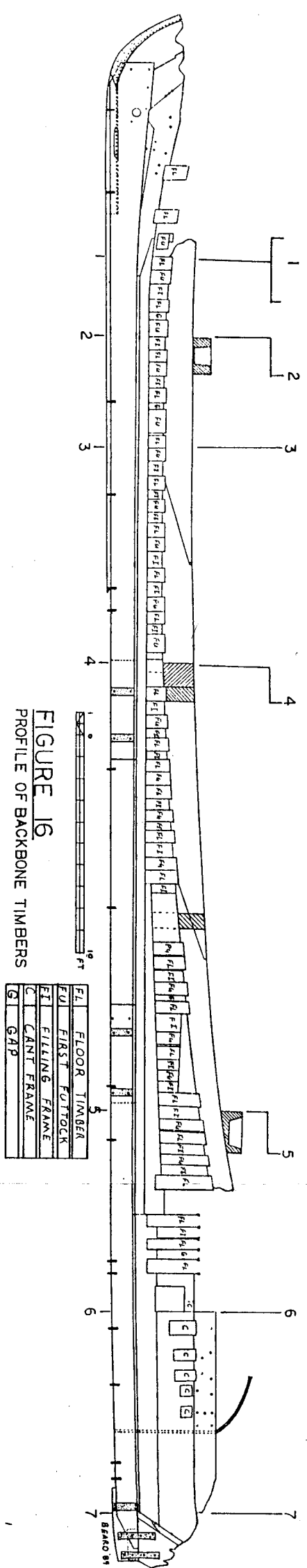
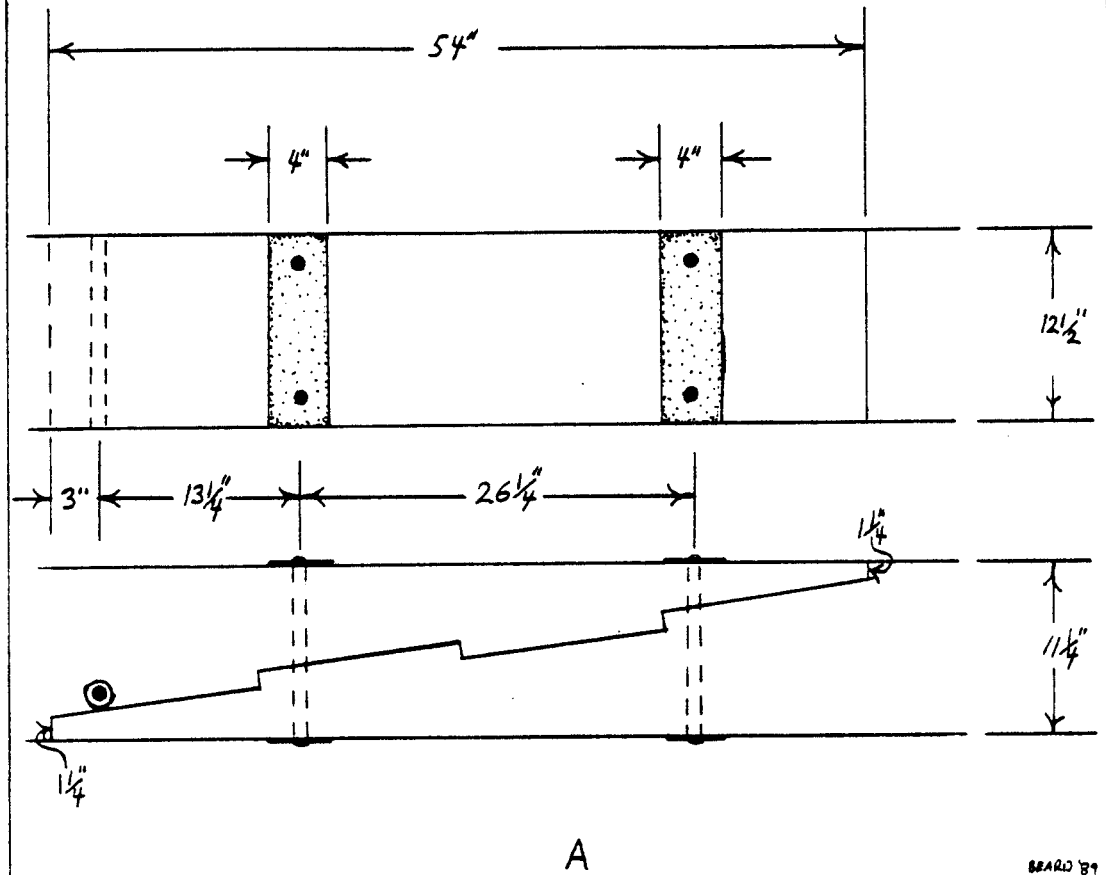

FIGURE 16
PROFILE OF BACKBONE TIMBERS

FL	FLOOR TIMBER
FJ	FIRST JOIST
FJ	FILLING FRAME
C	CANT FRAME
G	GAP

FIGURE 17: KEEL SCARPHS



A

BEARD 89

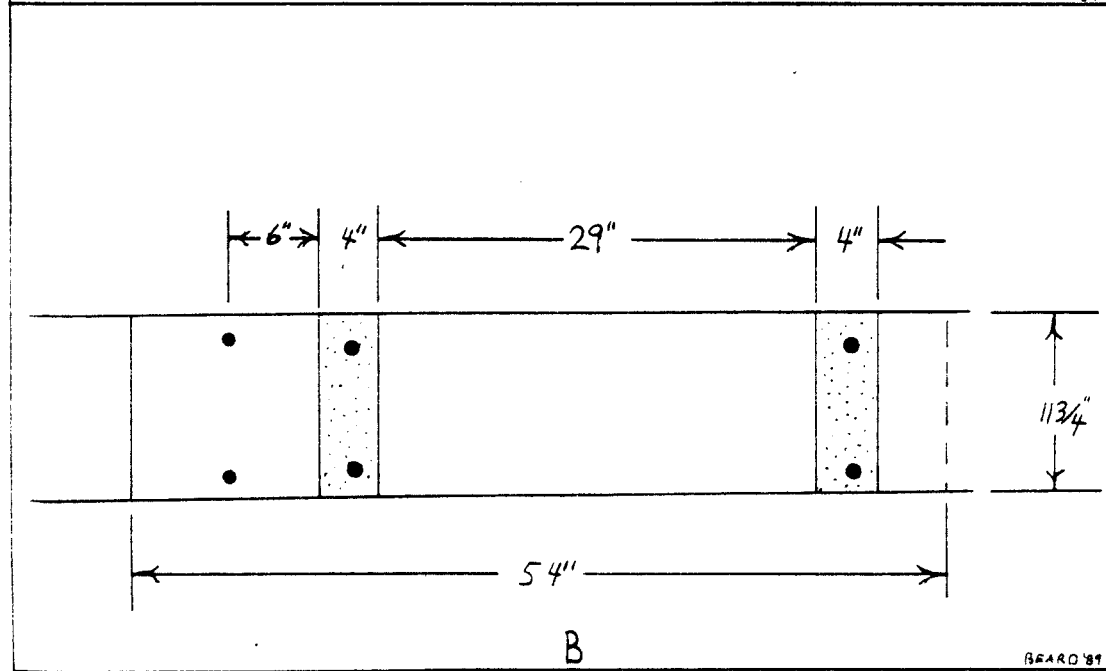

B

BEARD 89

corresponds exactly with the British Admiralty specifications for keel scarph joints.¹² These are a variation of hook-scarphing, with each face having four distinct plane surfaces, each approximately 13-1/2 inches long. Each scarph is held together by six 1-7/8 inches copper bolts, four of which pass through copper "fish plates" which are 4 inches wide and 3/8 inch thick, and whose lengths depend upon the dimension of the keel from base to garboard strake (Figs. 16 & 17).

The keel has a rabbet, sided 2-1/2 inches and molded 1-1/2 inches, cut into its top corners to accept the garboard strake. The rabbet in *DeBraak's* keel extends from the forward edge of the sternpost to approximately 9 feet, 9 inches aft of the forward end of the keel.¹³

False Keel

DeBraak's false keel, or "worm shoe" as it is sometimes called, extends down the full length of the bottom of the keel. This elm timber, which is sided the same as the keel and molded 2-1/4 inches, served three main purposes. First, in the event of grounding the false keel would easily tear off, sparing the keel from major damage. Second, it acted as an additional protection for the keel against the effects of boring marine worms, thus "worm shoe." Finally, by increasing the depth of the keel, it decreased the amount of leeway, or sideways movement as the vessel moved forward.¹⁴

Although most of the false keel was torn loose from the keel and lost when the hull was raised, data indicates that it consisted of three sections, probably scarphed, attached to the keel with large copper staples (Fig. 16). These staples were generally 5-1/2 inches long, 3/4 inch wide, 1/8 inch

thick, and having tines approximately 2-1/2 inches long. An additional section of false keel was incorporated into a repair of the keel, which will be discussed later.

Hog

The hog is a timber that runs along the top of most of the length of the keel (Fig. 16). It is the first piece of the "rising woods," or deadwoods. This timber is sided 13-1/2 inches and molded 5-1/4 inches. Approximately half of the molded dimension is tapered in to accept the approach of the garboard strake to the rabbet in the keel. *DeBraak's* hog is scarphed into the apron in the bow (Figs. 19 & 20) and extends to a point about 14 feet forward of the sternpost.¹⁵

An additional timber above the hog extends from the aft end of the hog forward for about 20 feet. Wedge shaped in profile, this timber is sided 13 inches and molded 11 inches at its aft end. At least one floor timber is let down into this timber just aft of the mainmast step (Fig. 18). Although this timber is not illustrated in any text on the subject, Goodwin suggests that this may be an example of a shipwright using up large offcuts of timber in order to minimize waste.¹⁶ This timber is a tropical hardwood, possibly indigenous to Maylasia. It may be the product of a Dutch refit while the ship was on station in the East Indies.¹⁷

FIGURE 18

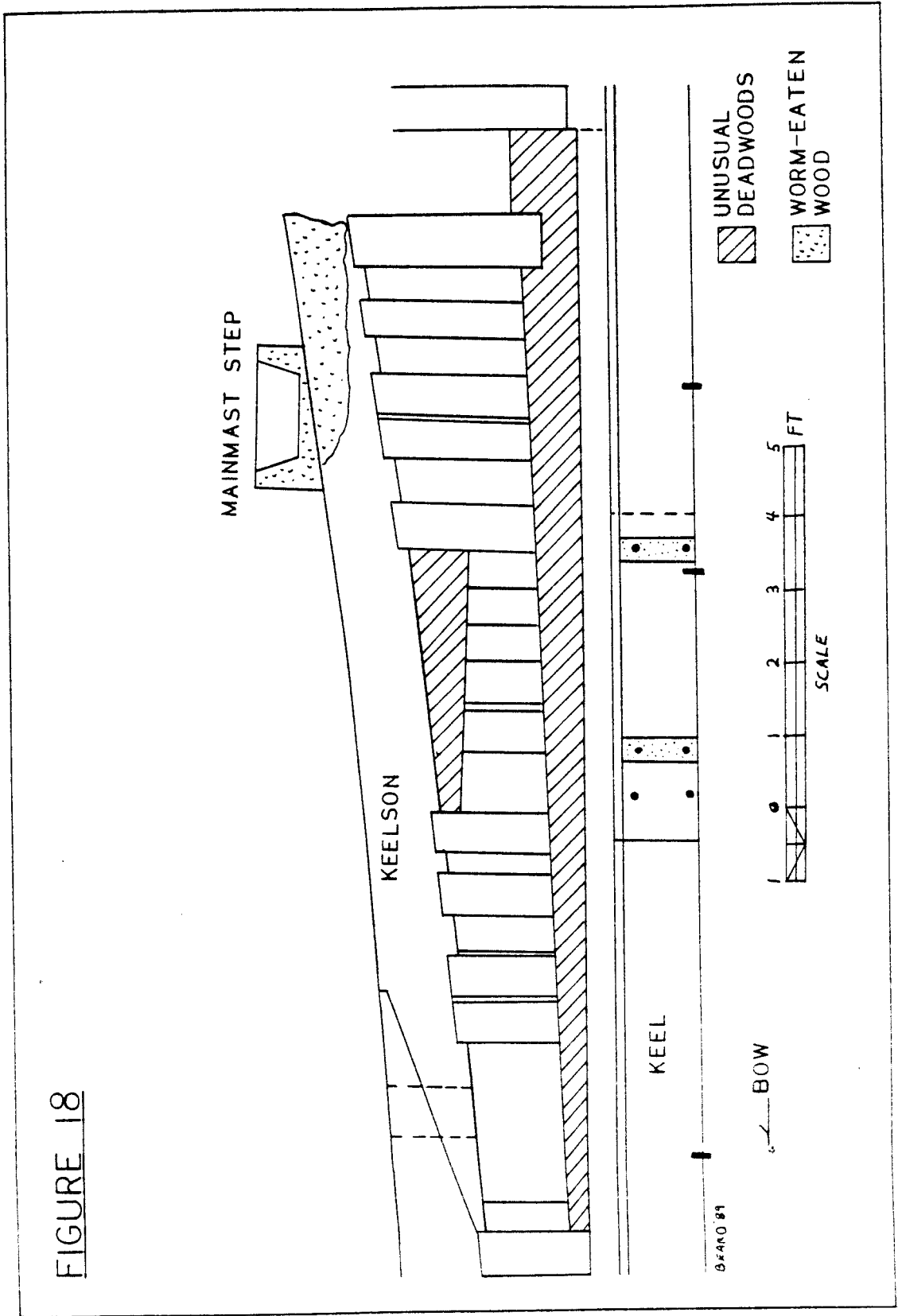

Stem Construction

The stem of *DeBraak*, like those of most vessels of the period, is made up of a number of pieces that are fayed into one another and tightly bolted together. Three components of the stem survive: the gripe, the stempost, and the apron. The gripe, or cutwater as it is sometimes called, is a large timber which is attached to the forward end of the keel by means of a mortice and tenon system and fastened into place with two 7/8 inch diameter copper drift pins. It is the forward most perpendicular of the ship and aids the ship in cutting through the water (hence the term "cutwater"). The gripe is partially sheathed with lead attached with large copper tacks (Fig. 19).

The stempost of the ship is the forwardmost timber used in actually holding the ship together. This timber is morticed into the top of the keel, and like the gripe is fastened with copper drift pins. It is fayed into the gripe (forward) and the apron (aft). A vertical rabbet is cut into the stempost into which the hull planks fit. At its base *DeBraak's* stempost is sided 10 inches and molded 1 foot, 10 inches (Fig. 19).

The apron is a curved timber which further assists in locking the stem to the keel. This timber, as it survives in *DeBraak*, extends 7 feet, 7 inches from the base of the stempost to the aftermost end of where it scarphs into the hog (Fig. 19). Along most of its length the apron is cut to accept the approach of the garboard strake and replaces the keel rabbet in this function (Fig. 20).

In the bow two places have stopwaters along major seams. Stopwaters are simply wooden dowels that are driven across the seam between two timbers, to stop the flow of water along the seam and also to help prevent

FIGURE 19

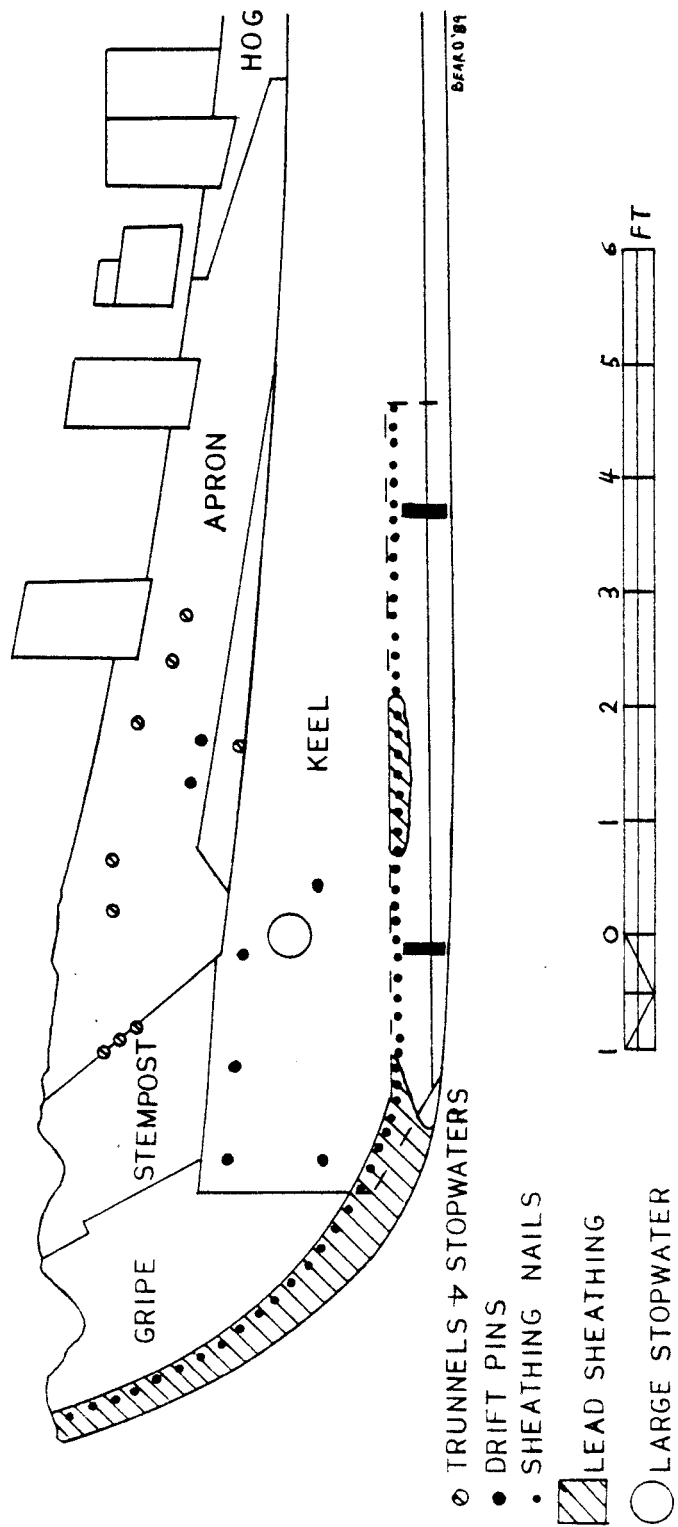
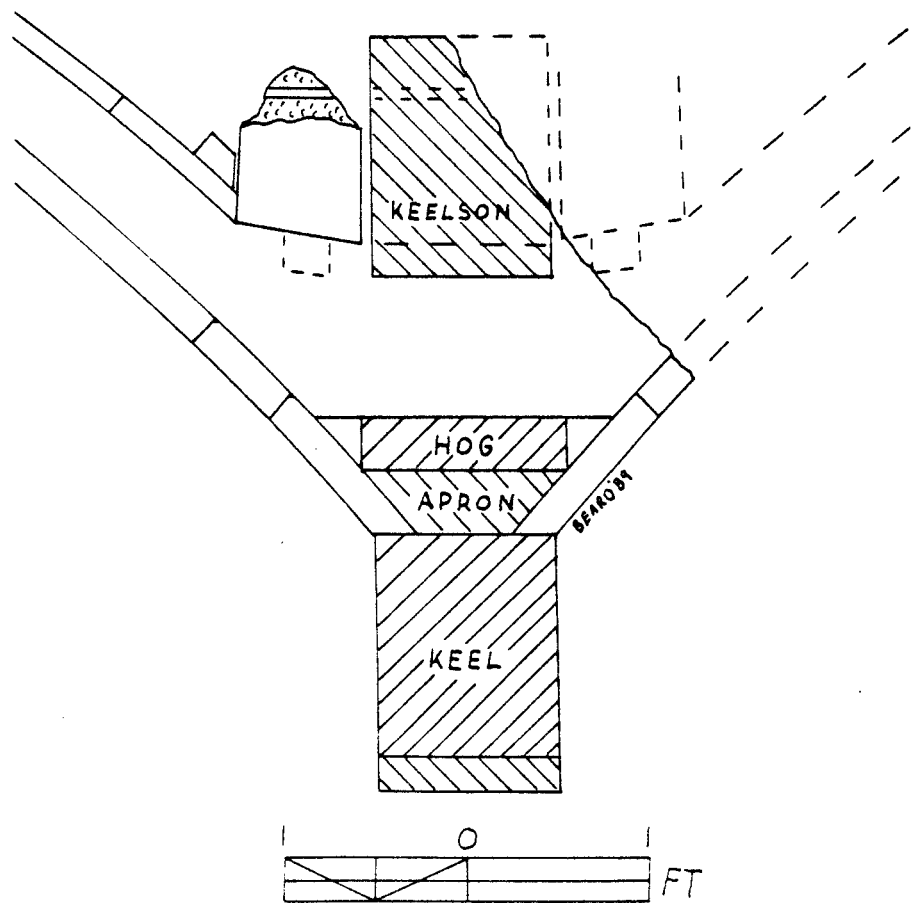

FIGURE 20



SECTION I ON BACKBONE TIMBER PROFILE

the timbers from shifting. Three trunnels are driven along the seam between the apron and the stem and one very large dowel is driven across the mortice along the aft end of the stempost tenon (Fig. 19).

Stern Construction

The surviving structural components of *DeBraak's* stern construction consist of a lower portion of the sternpost and three deadwood timbers or "rising woods." The sternpost has a rake of sixty degrees along its after face and one of fifty-four degrees on its forward face. The surviving portion of this timber is sided 9 inches and is molded 2 feet, 4-1/2 inches at its base. The molded dimension includes a 3 inch wide, 2-1/2 deep rabbet cut into the forward corners to accept the hull planks. The sternpost is morticed and tenoned into the keel, with its tenon being 1 foot, 4 inches long, 5-3/4 inches deep and 3 inches wide (Fig. 21).

Three stern deadwoods have survived relatively intact in *DeBraak's* hull. The lowest of these either butts against or is scarphed into the hog between 13 and 14 feet forward of the sternpost. The middle timber is the largest surviving deadwood and appears to have curved upward toward the sternpost forming a deadwood knee. This timber provides additional support in the same fashion as the non-extant sternson knee. The uppermost of the surviving deadwood timbers is the smallest of the three. Surviving evidence suggests that this timber's aftermost face either was fayed into the upwardly curving face of the middle surviving deadwood or helped form a scarph into which another deadwood could hook (Fig. 21).

FIGURE 21

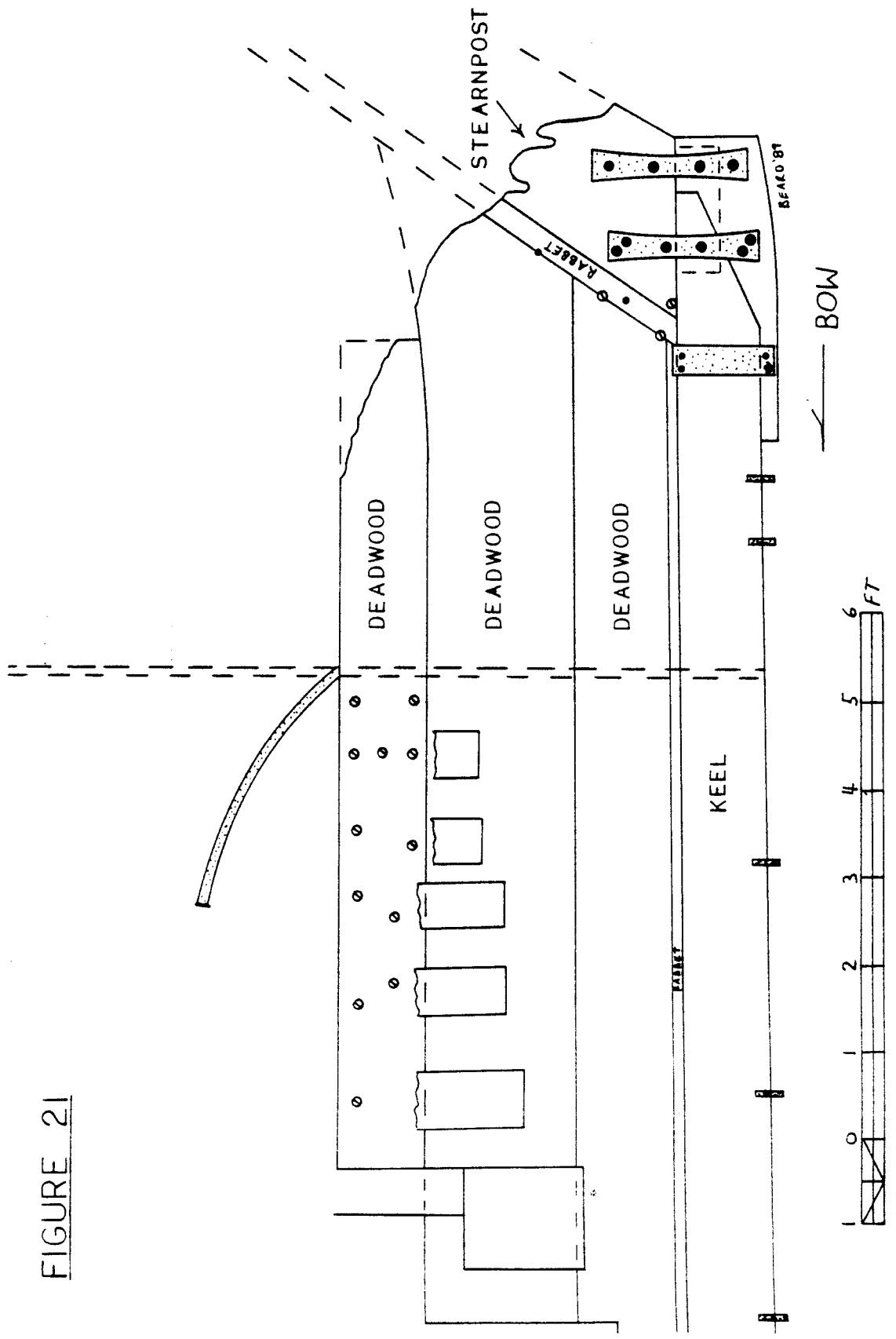
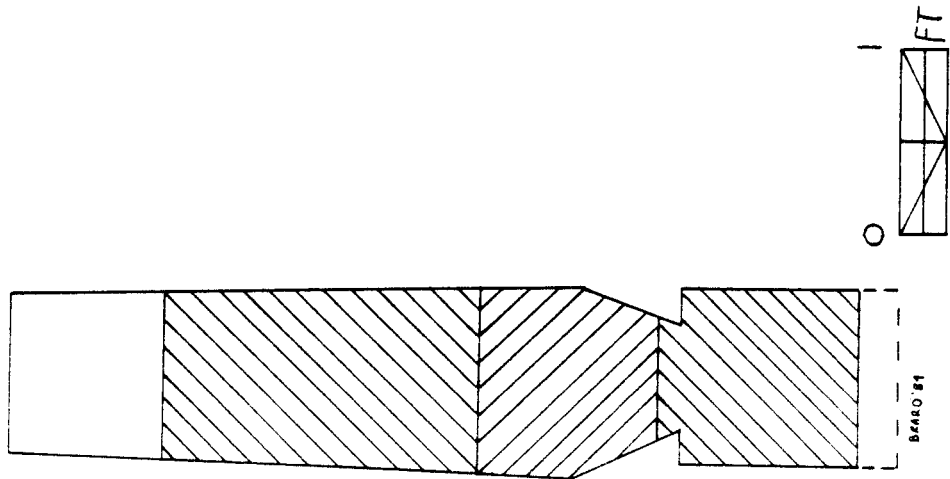
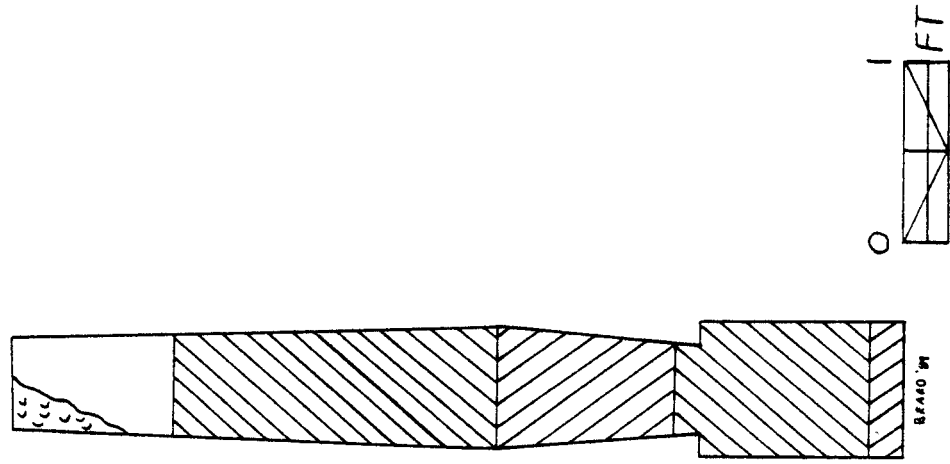

FIGURE 22



A. SECTION 6 ON BACKBONE TIMBER PROFILE



B. SECTION 7 ON BACKBONE TIMBER PROFILE

All of the deadwoods taper to reduced dimensions from fore to aft and from the keel up (Figs. 22). The Admiralty drafts and an extant drift pin through the deadwoods suggest that there were originally two or three more of these timbers, which have not survived (Fig. 21).

Framing

The framing of *DeBraak* appears to be, for the most part, fairly standard for the period, having a set of floor timbers, futtocks and filling timbers making up the ship's skeleton. Using available shipbuilding data from the last quarter of the eighteenth century, however, there are certain aspects to the framing of this vessel that do not appear to be standard. Another point of view is that certain "standard" practices in the art of the shipwright were followed during this period, but they frequently were only loosely followed and individual shipwrights followed their own experience or local traditions.

One of the "non-standard" aspects of *DeBraak's* framing is the lack of consistent room and space dimensions. Room and space is described as "the distance between the face edge of one complete (or main) frame and the equivalent face edge of the next frame."¹⁸ Although *DeBraak's* room and space is not of a constant, the arrangement of floor timbers, first futtocks and filling timbers generally is (Fig. 23). Ideally there would be a gap between the main and filling frames sufficient to allow proper ventilation to prevent dryrot. This technique apparently was not always followed in *DeBraak*, either during her construction or subsequent refits; there are sections, both at the floor timbers and at the futtocks above

FIGURE 23
 EXAMPLE OF
 FRAMING AT
 KEEL

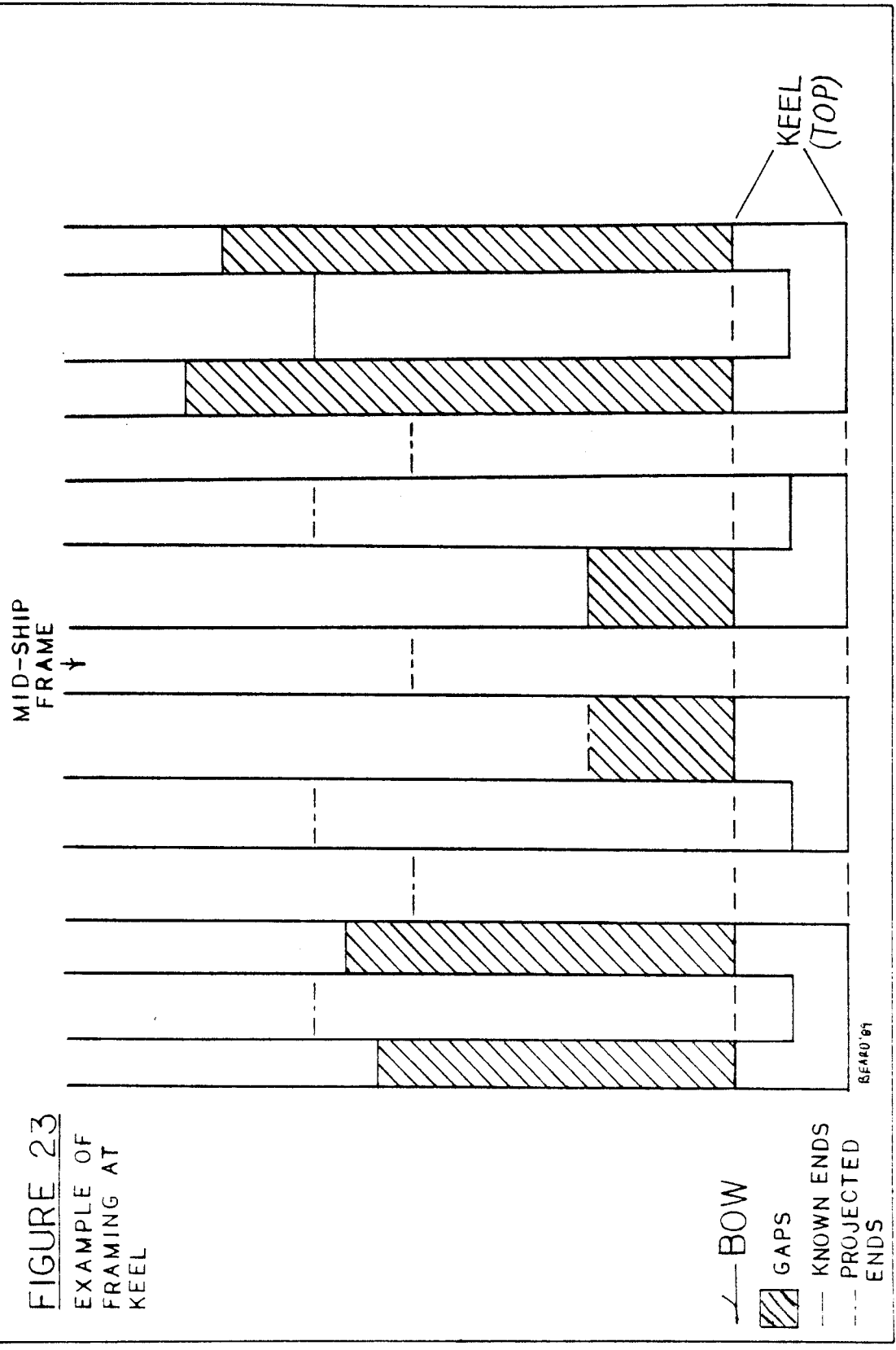

— BOW
 ▨ GAPS
 — KNOWN ENDS
 - - - PROJECTED ENDS

STERN

KEEL (TOP)

MID-SHIP
 FRAME
 ↓

the turn of the bilge, in which the timbers have no space for ventilation between them.

Another non-standard example of framing in *DeBraak* is the presence in at least two places of filling pieces that do not extend the full length of the frame, but instead fill elongated wedge-shaped gaps left by divergent or convergent timbers. The reason for this arrangement is not clear, but it may indicate a scarcity of timbers of the needed dimensions.

The molded dimensions of the floor timbers and inboard ends of the first futtocks depends upon the rise of the floors. Therefore at the dead-flat or point of extreme beam of *DeBraak* the floor timbers are generally molded 9 inches.¹⁹ In the stern forward of the deadwoods the composite or half-floors are molded as much as 23 inches (Fig. 24).

The sided dimensions of these timbers vary from approximately 5 inches to 10 inches. Most of the floors are notched with limber holes, which allow water to flow along the sides of the hog and to the bilge pumps. *DeBraak's* limber holes are essentially extensions of the floors' inletting to straddle the hog. Another common British practice was to cut separate holes in the floors and futtocks slightly outboard of the keel (Fig. 25).²⁰

The frames of *DeBraak* taper rapidly as they move outboard and upward from the keel to reach a fairly consistent molded dimension of 6 inches. The sided dimensions of the futtocks at the outboard surviving ends vary from 3-5/8 inches to 9-1/2 inches over much of the vessel's length. Several of the bow cant frames are sided 10 and 12 inches.

DeBraak's futtocks butt against one another. Contemporary essays on ship construction and their modern counterparts usually refer to the use of

FIGURE 24. EXTREMES OF MOLDED FLOOR DIMENSIONS

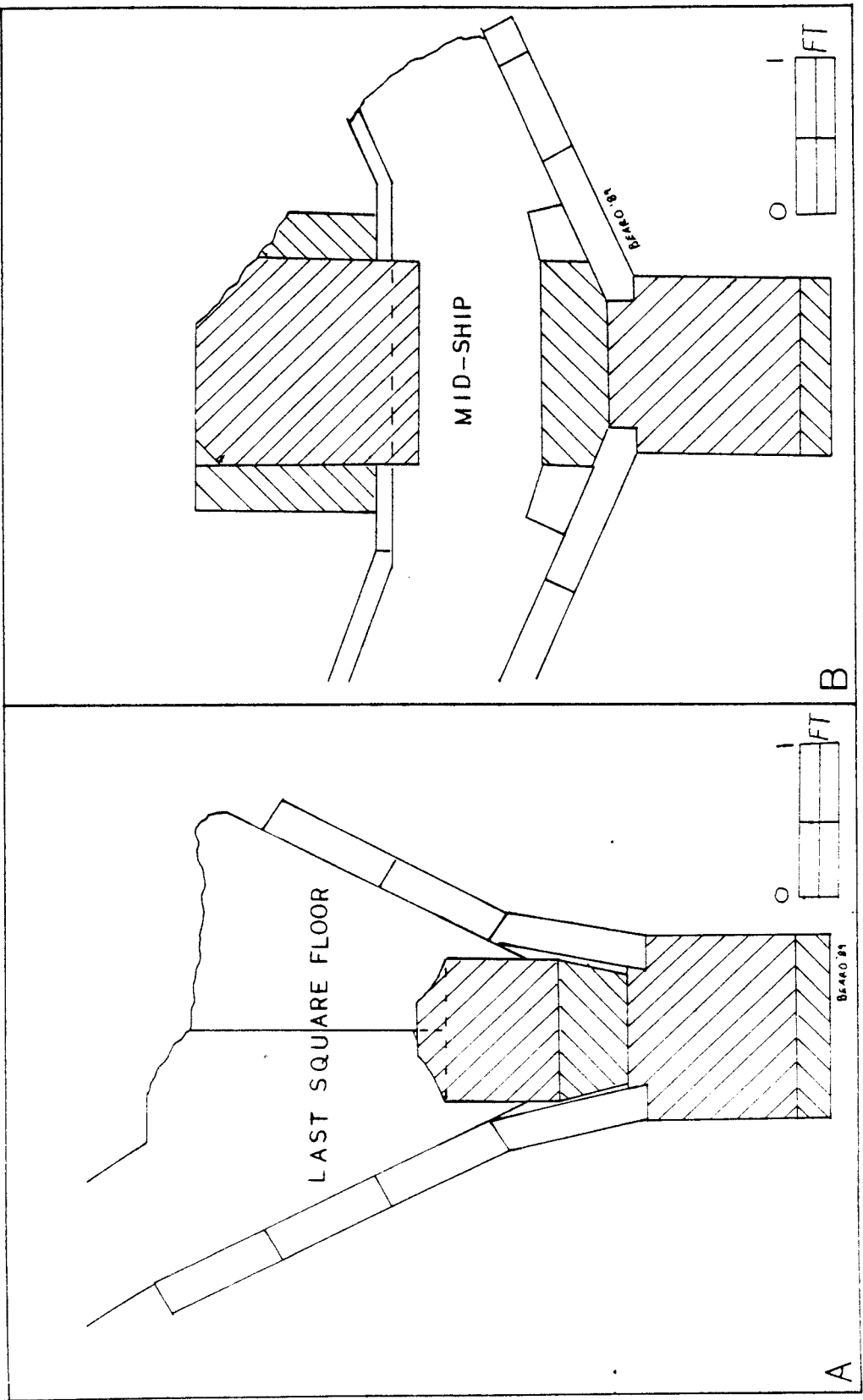
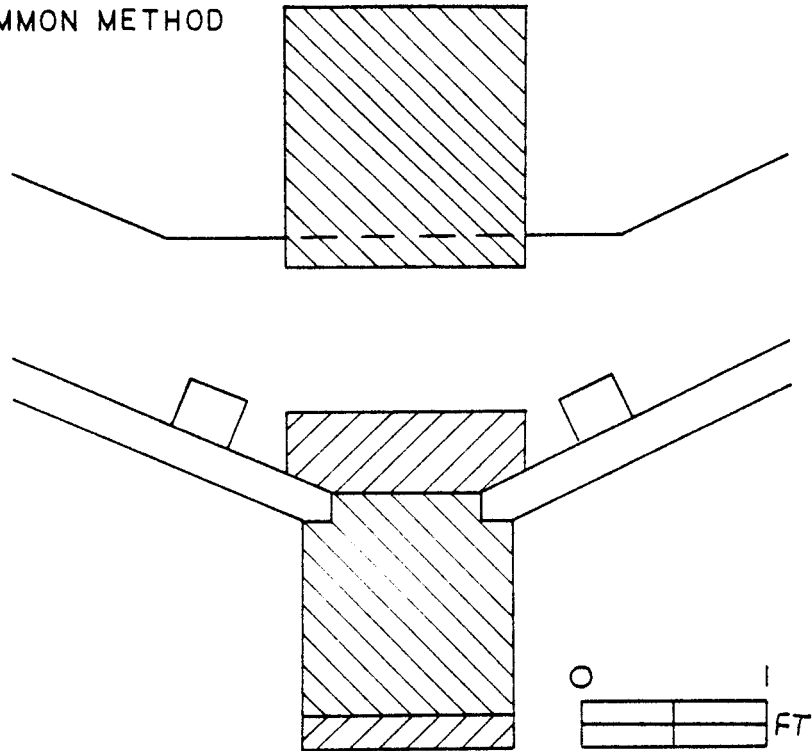

FIGURE 25: LIMBER HOLES

A ONE COMMON METHOD



BEARD '89

B DEBRAAK'S
LIMBER HOLES

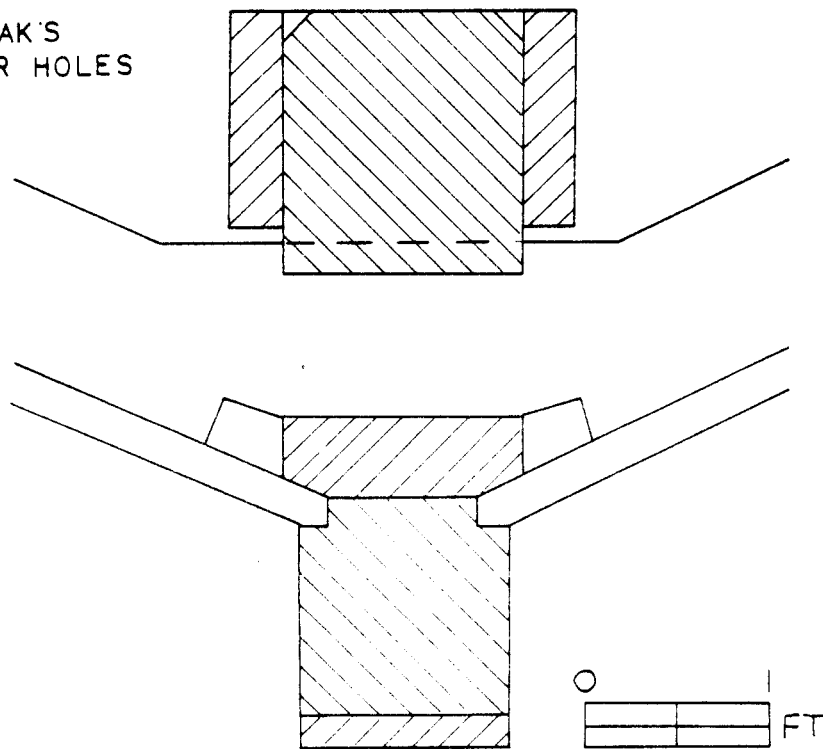

BEARD '89

FIGURE 26. EXAMPLES OF FUTTOCKS BUTTING AND CHOCKING

A BUTTING

B CHOCKING

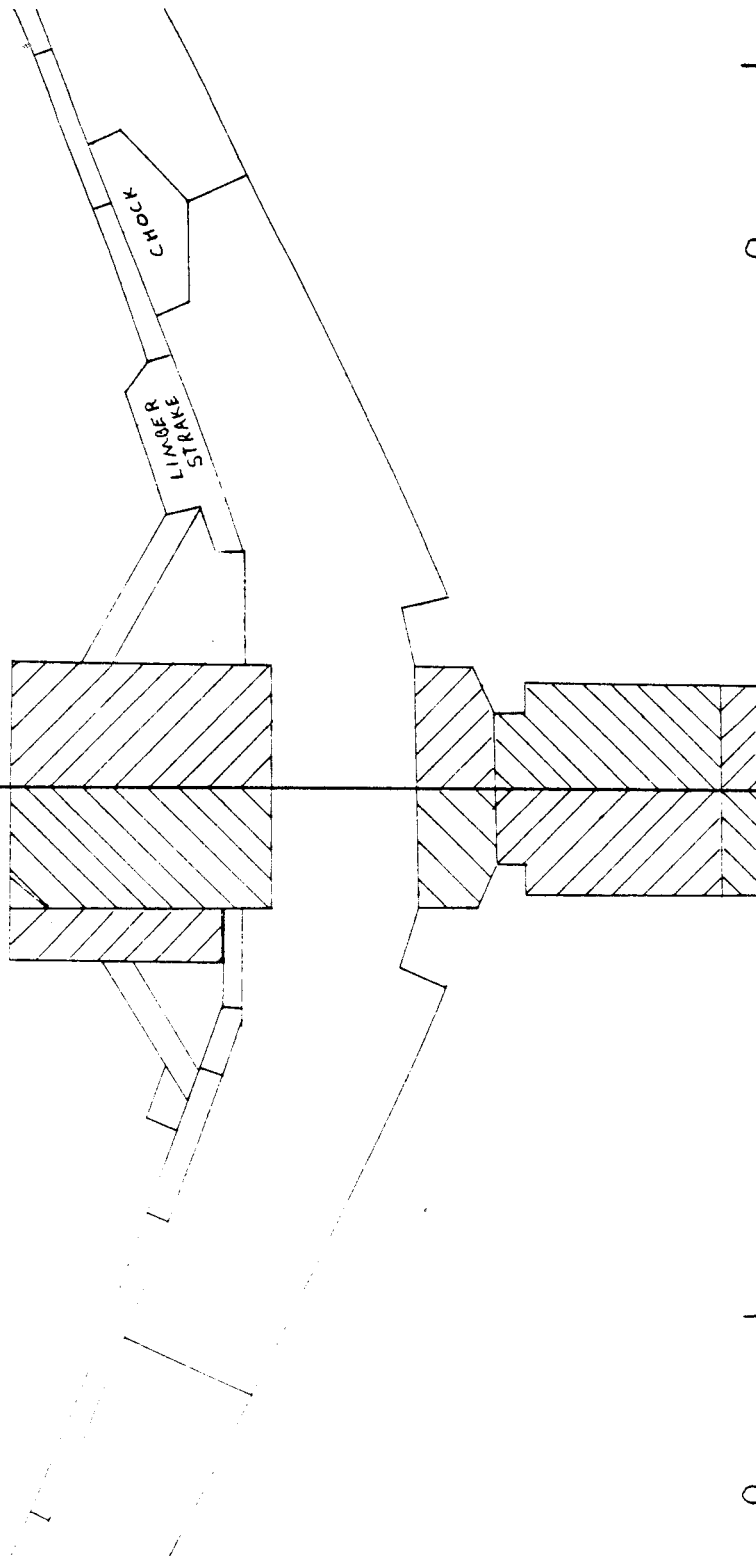

butt chocks where the futtocks join (Fig. 26).²¹

As has been previously mentioned, the square frames of *DeBraak* cross the keel or butt together on its center line. The cant frames, however, are fayed into the sides of the apron (forward) and the deadwoods (aft). The cant frames in the stern are trunneled to the deadwoods and the hull planking while, those in the bow are fastened only to the hull planking (Figs. 16 & 21).

Due to incomplete data, it is not possible to produce a framing plan for *DeBraak*. It is hoped that future research will fill this gap in the architectural analysis of the vessel.

Keelson

DeBraak's keelson, like her keel, is made up of three baulks (Fig. 16). These baulks are locked together at two horizontal flat scarph joints, which give shift to the scarphs of the keel. "Giving shift" means staggering joints, much like the bricks of a wall, to increase the strength of the structure.²² The keelson scarphs are 3 feet, 7 inches long with ends nibbed 1-1/2 inches. These scarphs are somewhat shorter than Admiralty specifications (Fig. 28 a & b).²³ This may be a result of an individual shipwright's personal preference, or the keelson may have been replaced during a refit by the French or Dutch.

At the dead-flat of the keelson is sided and molded 16-1/2 inches. Both of these dimensions diminish with the run fore and aft. At the mainmast step the keelson is 12 inches square and at the foremast step it is sided 12 inches and molded 15-1/2 inches. The Admiralty drafts show that the

FIGURE 27: KEELSON SCARPHS

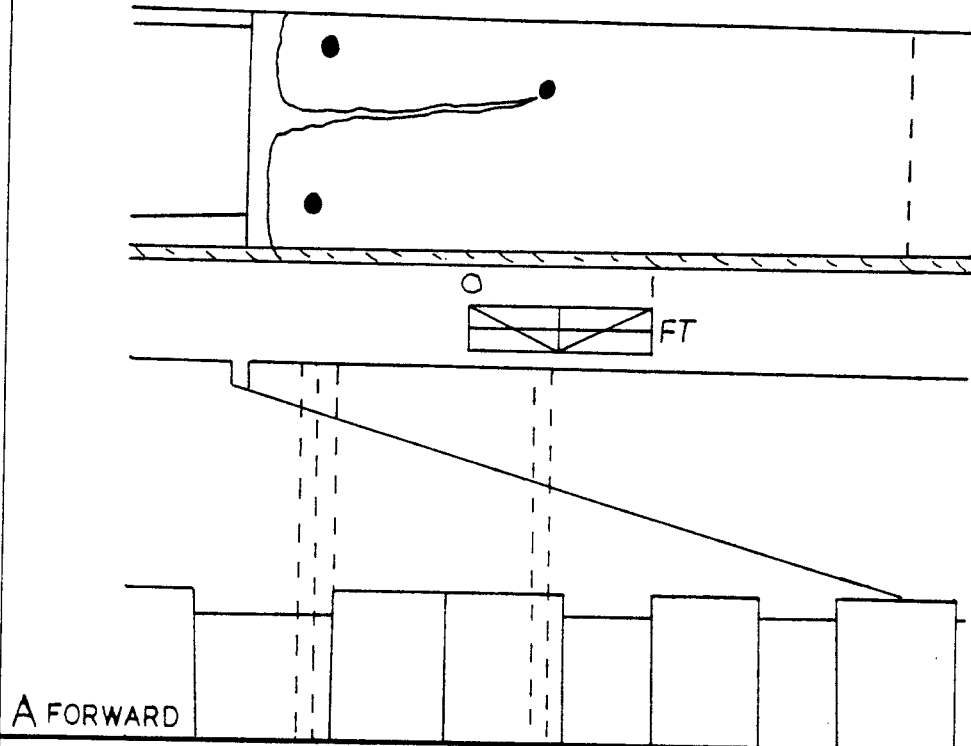

BEARD '89

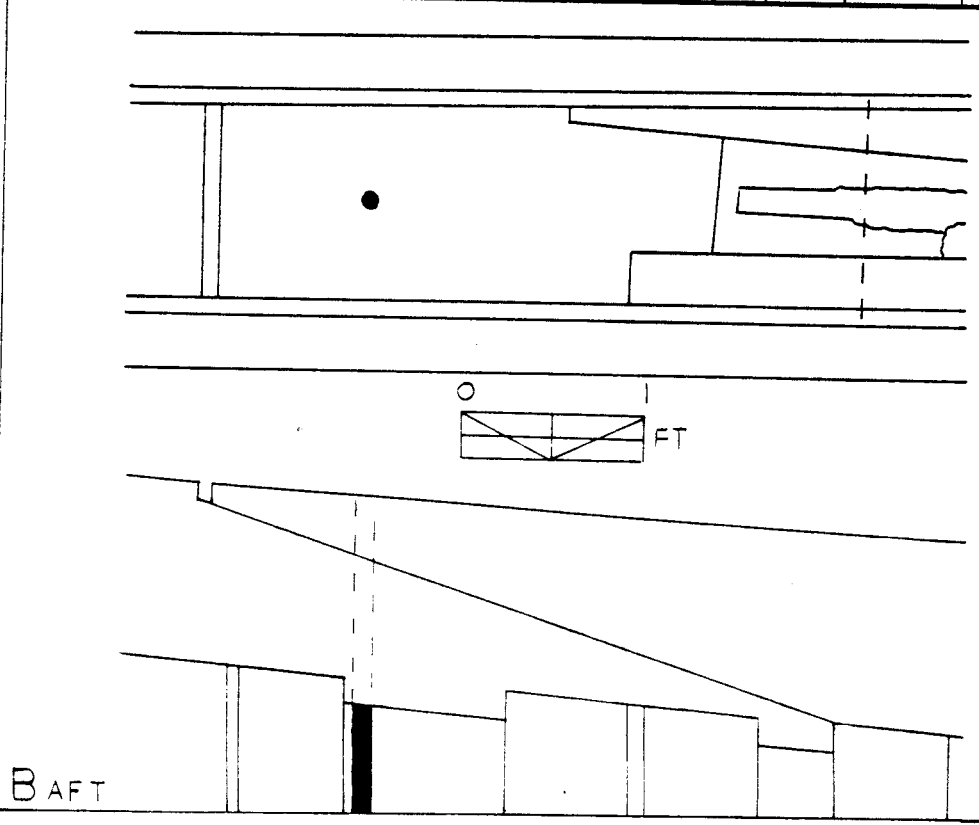

BEARD '89

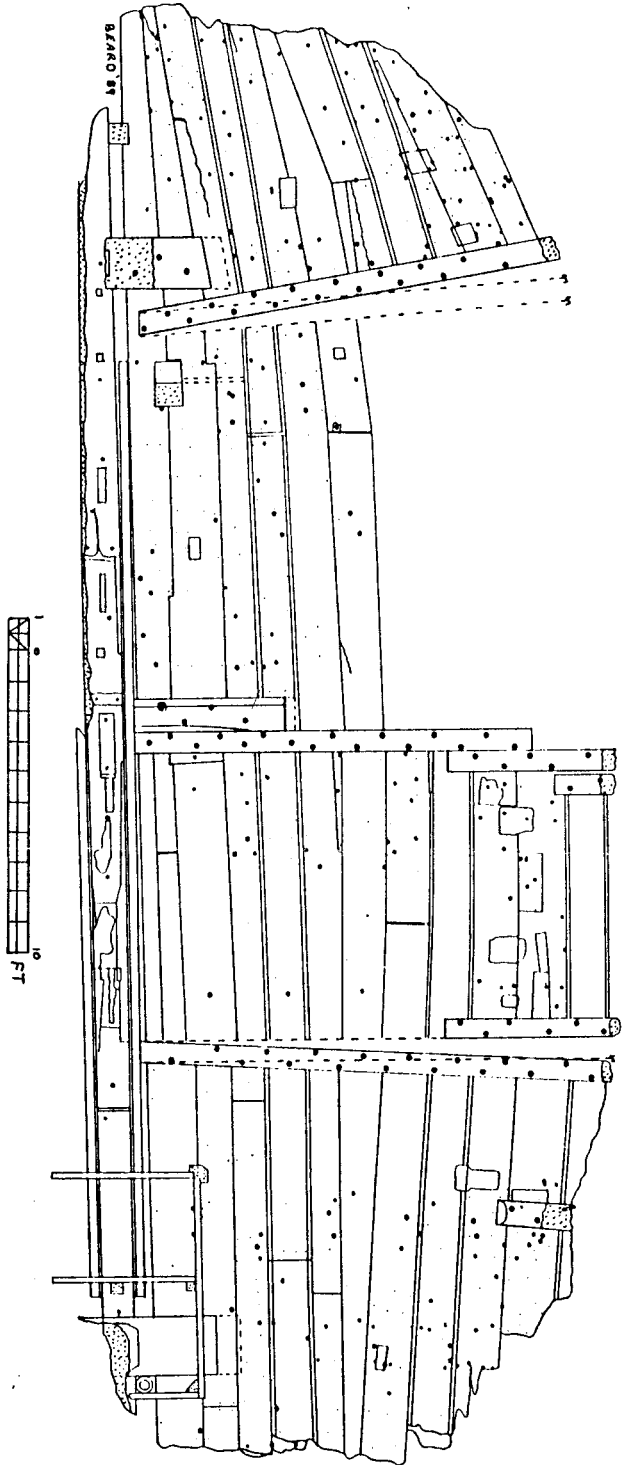

FIGURE 28. PLAN VIEW OF KEELSON AND CEILING PLANKING EXPANSION

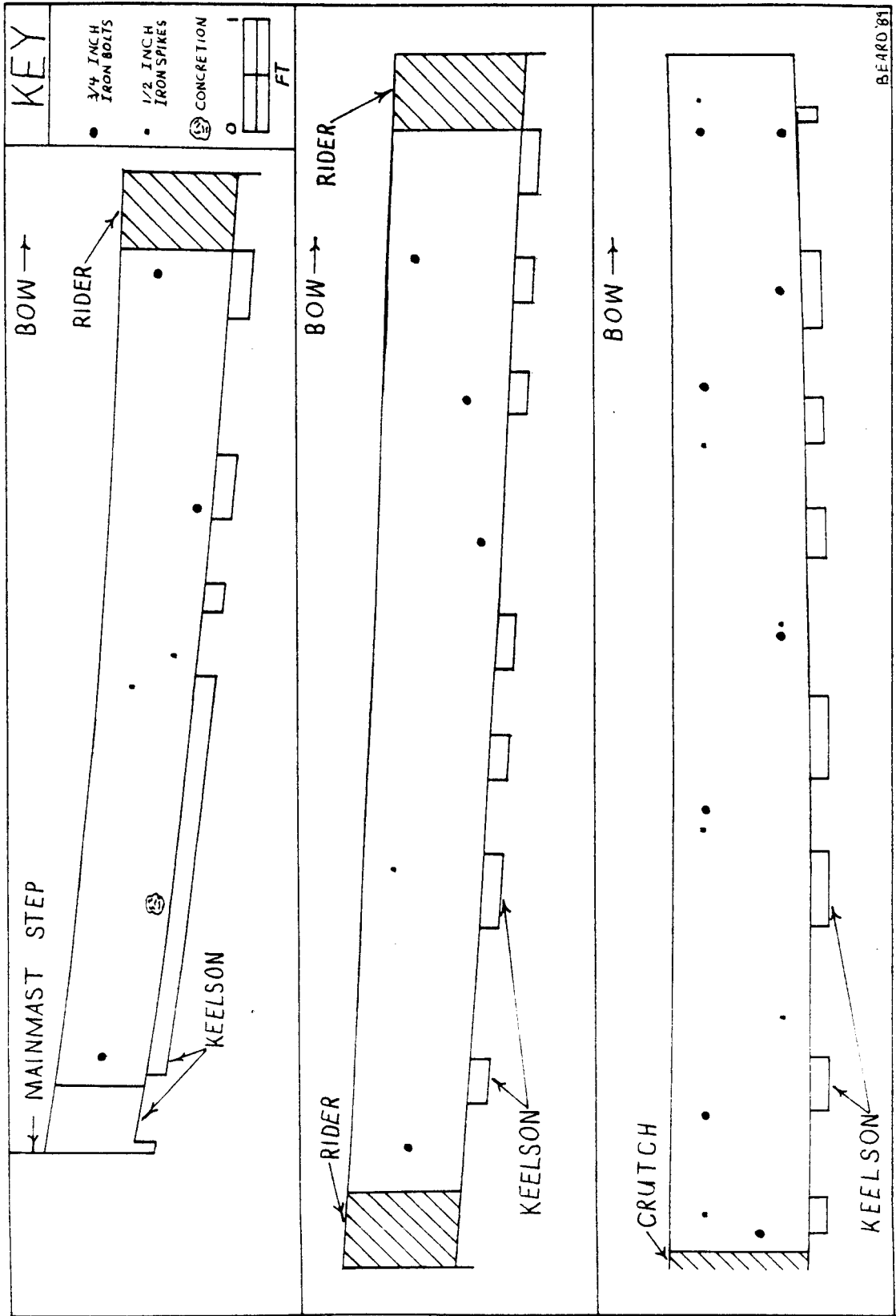

FIGURE 29: CHEEK FASTENER PATTERN

keelson's molded dimension decreases to the point where it scarphs into the bow and stern deadwoods. Data recovered from the hull seems to bear this out (Figs. 12 & 16).

The bottom of the keelson is inletted to receive the floor timbers. This inletting averages 2 inches deep, and added strength to the structure once it was bolted tightly together by locking the timbers in place. This same inletting has been recorded on a small British gunboat raised from the St. Lawrence River in Canada in 1967 and a British brig investigated in 1982 in the Poultney River in New York. Both vessels were built during the War of 1812.²⁴

The top of the keelson has a number of mortices cut into it, probably to accept the tenons of pillars used to support the lower deck (Fig. 27). One very large mortice a little aft of midship served as the mast step when *DeBraak* was a cutter. Mast steps will be discussed in more detail later. The top edges of the keelson are chamfered or beveled.

Associated with *DeBraak's* keelson are two timbers that are not described in any of the texts consulted concerning late eighteenth-century British ship architecture. These "cheeks," or "doubling" as they are often called, act to give added support to the keelson by sandwiching its three baulks together (Fig. 27). These two planks stretch from about 7 inches forward of the mainmast step to 2 feet, 4 inches aft of the foremast step. Each is a single plank 3 inches thick and from 12 inches (at its aft and forward ends) to 14 inches (midships) wide. They are fastened to the keelson with a combination of iron drift pins and large iron spikes (Fig. 29). The gaps left between the top of the keelson and the cheeks are filled with strips of wood which are

strips of wood which are triangular in section (Fig.33, p. 124).

Hull Planking

Little detailed information about *DeBraak's* hull planking has been accumulated at this time. The major reason for this is that most of the surviving hull planking is on the starboard side, which is still fully sheathed with copper. There are no plans to remove this sheathing until the hull's final disposition is determined and it can be moved to a better location for carrying out this operation.

Measurements taken along the accessible port side indicate that hull planks vary in thickness from 2-1/4 to 2-7/8 inches. Goodwin and others state that it was common for the garboard strake to be considerably thicker than the rest of the hull planking.²⁵ This is not the case in *DeBraak*, whose the garboard strake is 2-1/2 inches thick.

The widths of the hull planks vary, as they would in any wooden vessel, but the long runs of planking amidships average 9 inches wide. Some staler planks are visible where sheathing is missing. The purpose of these long trapezoidal planks was to allow for the varying curvature of the hulls cross-sections fore and aft. Planks are fastened to the frames with a combination of wooden trunnels, copper drift pins and copper spikes.

Ceiling Planking

DeBraak's ceiling planking is much easier to study since about forty percent of the starboard side remains. There is one section of ceiling (arbitrary hull Section 2) where damage left by the lifting cables makes the data incomplete (Fig. 27). Despite this damage, the general structural nature

FIGURE 30
THICKSTUFF

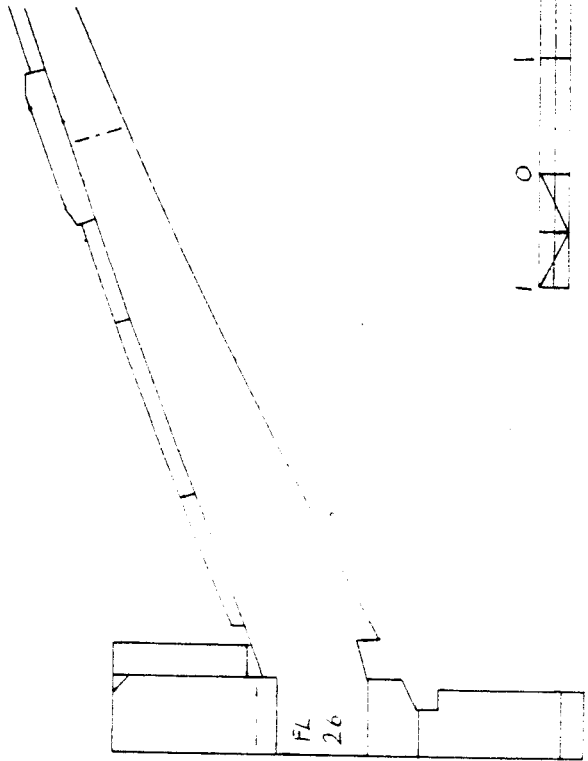
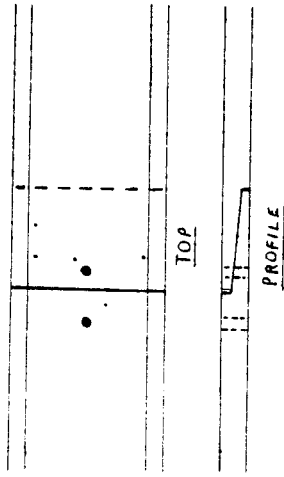

GF4081

FIGURE 31: BULWARK FRAGMENT

A. WITH CONCRETED SOLID SHOT IN-SITU

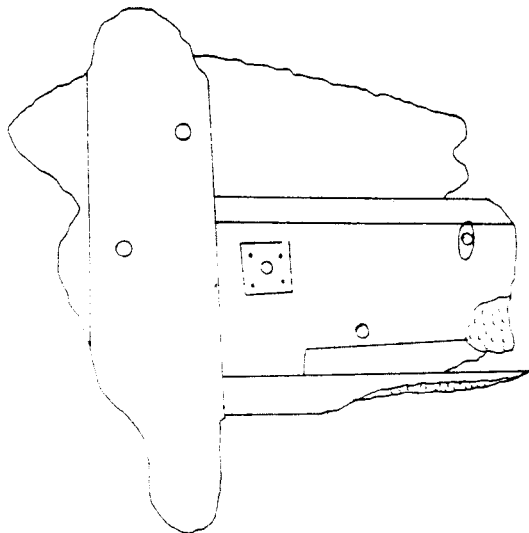
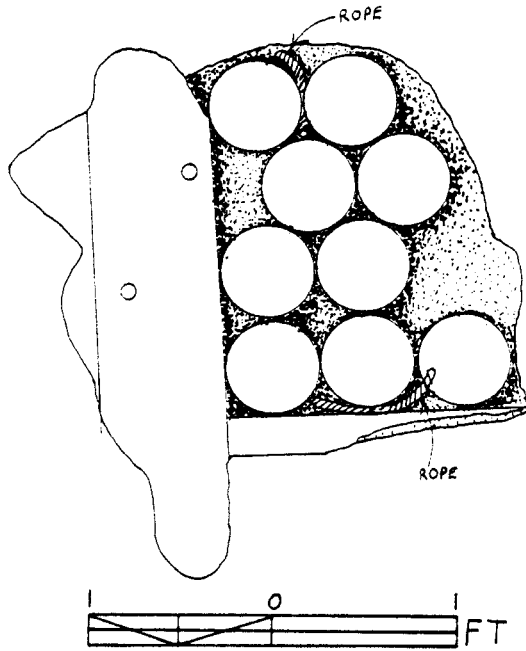

B. WITH SHOT REMOVED

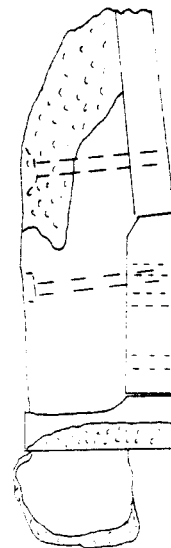

C. PROFILE

of the ceiling planking can be determined.

The surviving ceiling planks average 1-1/2 inches thick. The widths vary from 5-1/2 inches to 22 inches. There are numerous stealers in the bow and one in the stern. In the middle two sections of the hull (arbitrary hull Sections 2 and 3) the planks generally have a straight run (Fig. 27).

Besides the basic ceiling planks, several "thick stuff" planks survive on *DeBraak's* hull. These planks average 2-1/2 inches thick, have chamfered top edges, and add additional strength where one futtock butts the next. These timbers are sometimes referred to as fore and aft longitudinals, or stringers.²⁶ While the rest of the ceiling planks is butt-joined end-to-end over frames, the thickstuff is joined fore and aft with scarph joints about 10-1/2 inches long, fastened with 1-inch diameter iron bolts (Fig. 30).

Like the hull planking, *DeBraak's* ceiling is fastened into place with a combination of trunnels, drift pins, large spikes, and nails. In this case the spikes and nails used were iron. Also, unlike the hull planking, there is no discernible consistent pattern to the fasteners (Fig. 27).

Surprisingly, one small section of deck bulwark ceiling planking survived. This section, which is about 2 feet, 9 inches wide and 2 feet, 1 inch high, consists of part of an upper rider, waterway plank, spirketing, a concreted ring-bolt for serving and restraining a gun, and badly degraded top-timber (Fig. 31b). The reason for the survival of this piece is that when the ship heeled over and sank, seven 24-pounder solid shot rolled from a shot garland and settled in a cluster against the rider (Fig. 31a). Iron oxide from the shot penetrated the wood to such an extent that it became unpalatable to the toredo worms, which then ate around it, leaving the piece to be buried in

sand about 10 feet out from the articulated hull remains.²⁷

Riders and Knees

Riders act as an additional set of frames. These heavy transverse timbers "ride" over the ceiling planking. On larger classes of ships there might be a set of riders for each futtock. In *DeBraak's* case, there appear to be only what can best be described as lower and upper riders. Riders are located at three points along the ship's interior. The aftermost two of these butt against the keelson and have molded dimensions close to those of the keelson at those points (Figs. 27 & 33). The forward rider comes down from a point originally located above the lower deck to a rounded end 9 inches out from the keelson. Also associated with the aftermost riders are the remnants of the upper riders (Figs. 27 & 33). Except for their butt ends and some of their outboard dimensions the riders have an average molded and sided dimension of 8-1/2 inches. The top edges are chamfered.

The riders apparently are fastened through the ceiling, frames and hull with a "staggered" pattern of copper drift pins, which are 1-7/8 inches in diameter (Fig. 27). Data from the degraded port side makes it clear that these drift pins go all the way through the hull.

Remnants of two hanging knees are extant in *DeBraak's* hull. A third knee was recovered during the dredging operation and appears to have been torn loose from the portion of the hull which was heavily damaged by the lifting cables. Also fastened with drift pins, the foremost surviving knee remnant is molded and sided 8 inches, while the aftermost knee is sided 9-1/2 inches and molded 9 inches. Their lower ends are rounded in profile like the rider ends (Figs. 27 & 33). The top edges of the knees are

chamfered.

Breasthook

There are no extant breasthooks in *DeBraak's* hull. There is, however, some evidence that at least one of her breast hooks was reinforced with iron, a relatively new method in 1798. Figure 32 shows a wrought-iron fitting recovered from near *DeBraak's* bow. Although this fitting was badly degraded, examination revealed that it consists of two pieces of iron which are laminated together at its crotch. The fasteners are not evenly spaced, but appear to have been 5/8 inch in diameter iron drift pins. Its dimensions and the spacing of the fastener holes suggests that this fitting served either as a breast hook in itself or as part of a composite breasthook. Iron reinforcing of ship timbers did not become standard practice in the Royal Navy until the early nineteenth century.

Mast Steps

When *DeBraak* sank she was rigged with two masts, yet the remnants of three mast steps are extant within her hull. The reason for this is that she was originally rigged as a cutter, whose mast was stepped at a point slightly forward of midships (Fig. 11, p. 84). During *DeBraak's* refit in 1797, when she was converted into a brig, the cutter mast was merely removed and the two new steps were put into place.

The cutter mast step was simply a mortice cut directly into the keelson. This mortice is 25-1/2 inches long, 5-1/2 inches wide and 7 inches deep. Besides one of the long lower riders for lateral support, there is a short

FIGURE 32: IRON BREASTHOOK

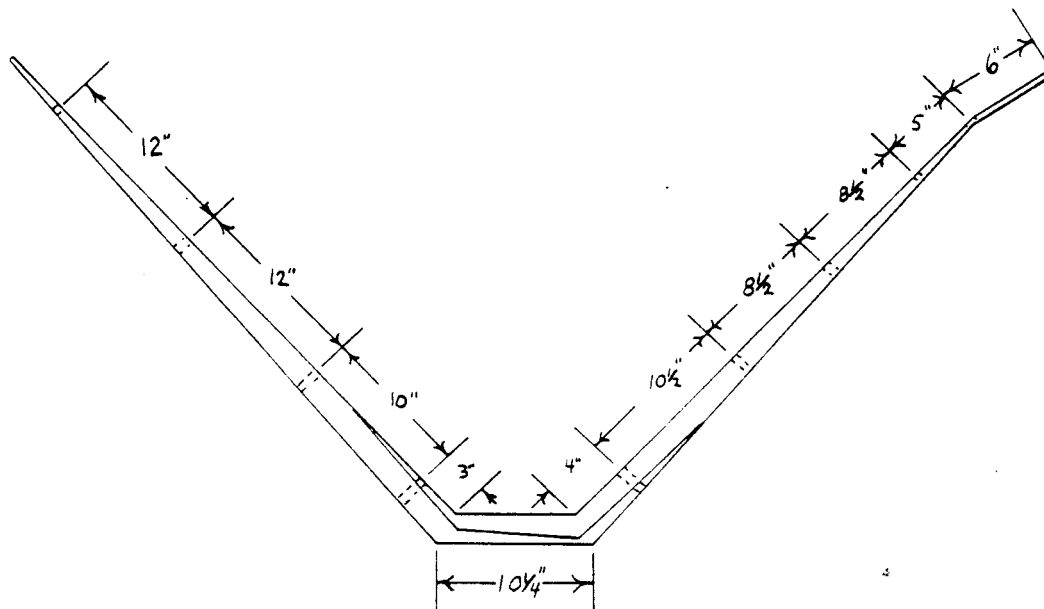
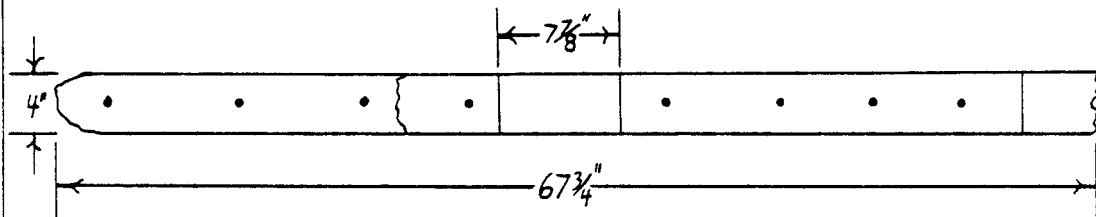

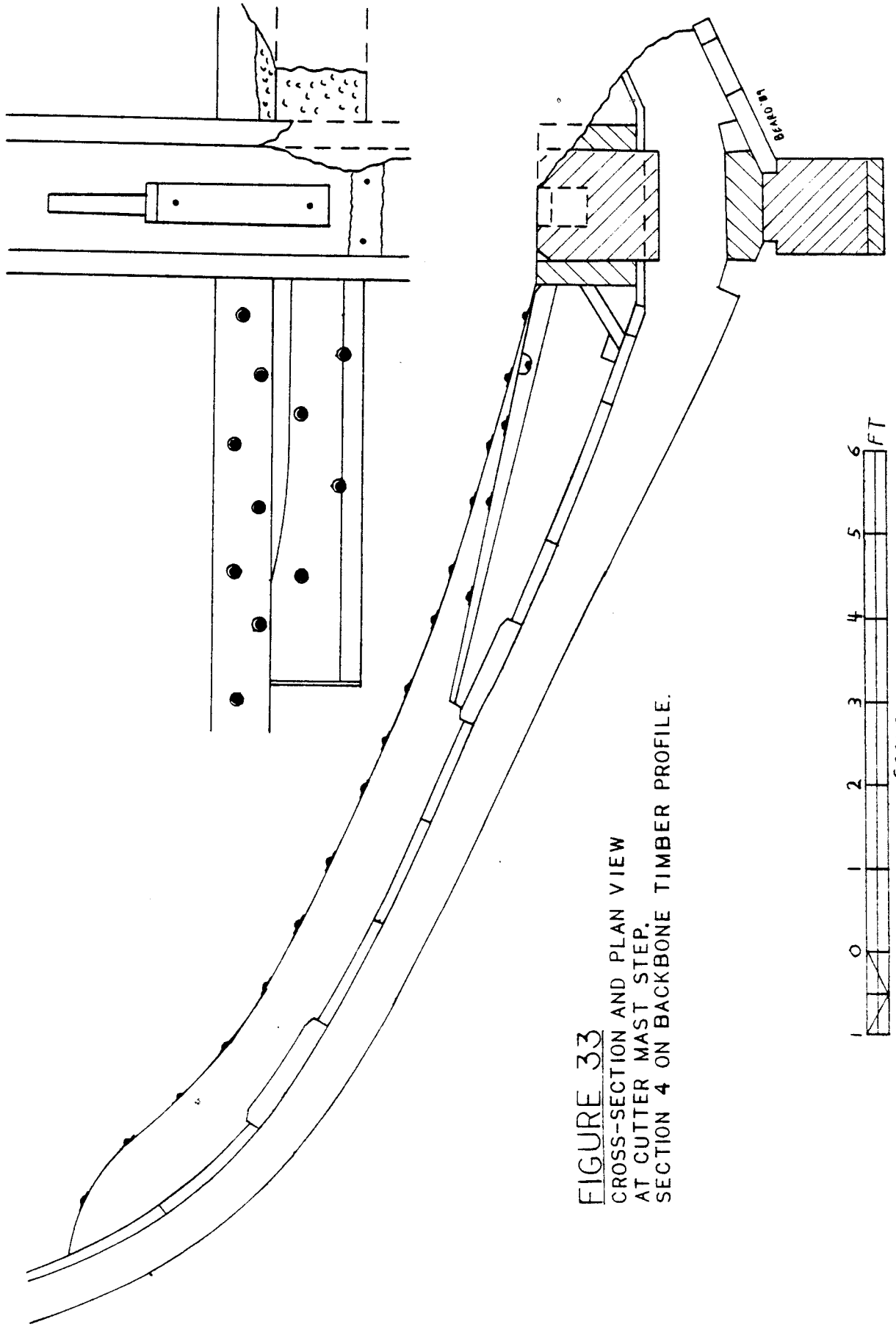

FIGURE 33
 CROSS-SECTION AND PLAN VIEW
 AT CUTTER MAST STEP.
 SECTION 4 ON BACKBONE TIMBER PROFILE.

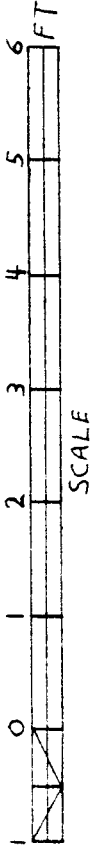
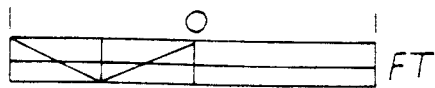
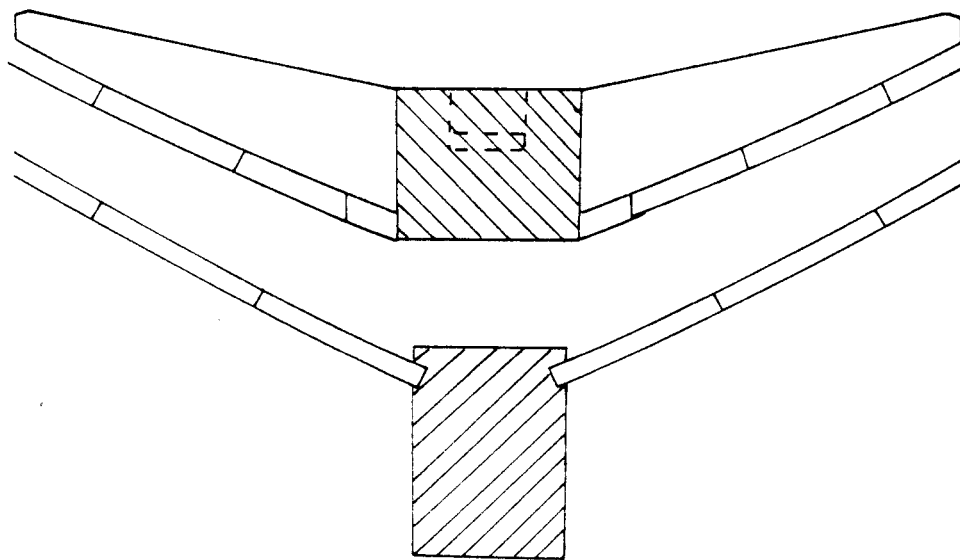
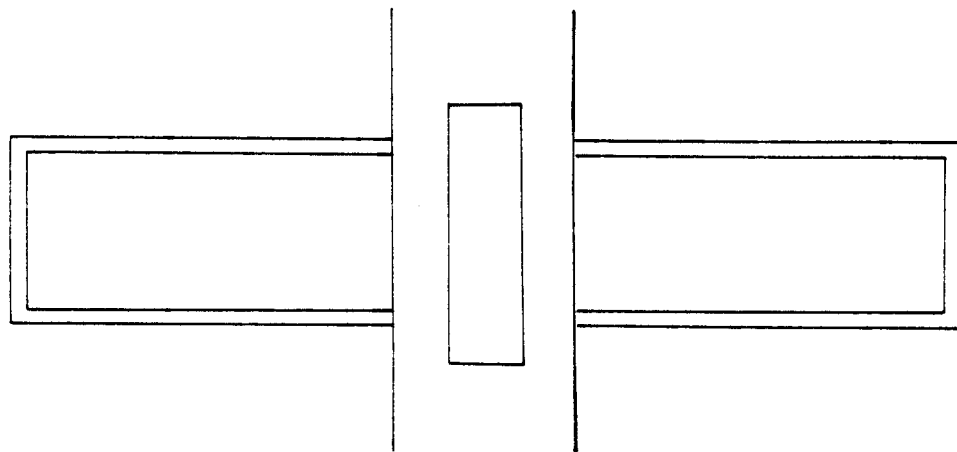

FIGURE 34

CROSS-SECTION AND PLAN VIEW
OF DEFENSE MAINMAST STEP



(REDRAWN COURTESY OF DAVID SWITZER)

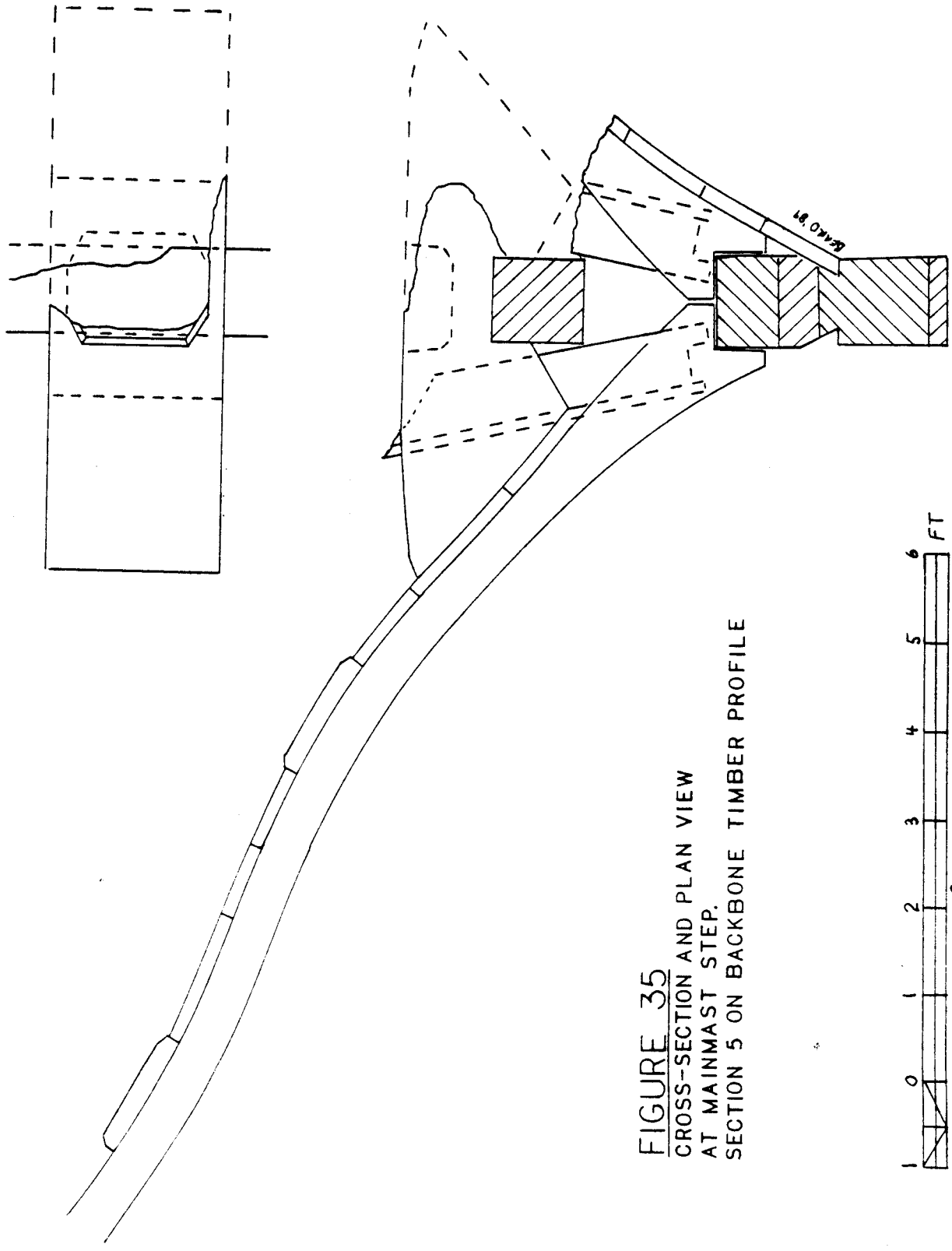
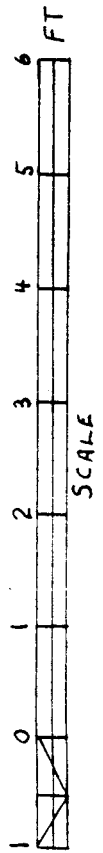

FIGURE 35
 CROSS-SECTION AND PLAN VIEW
 AT MAINMAST STEP.
 SECTION 5 ON BACKBONE TIMBER PROFILE



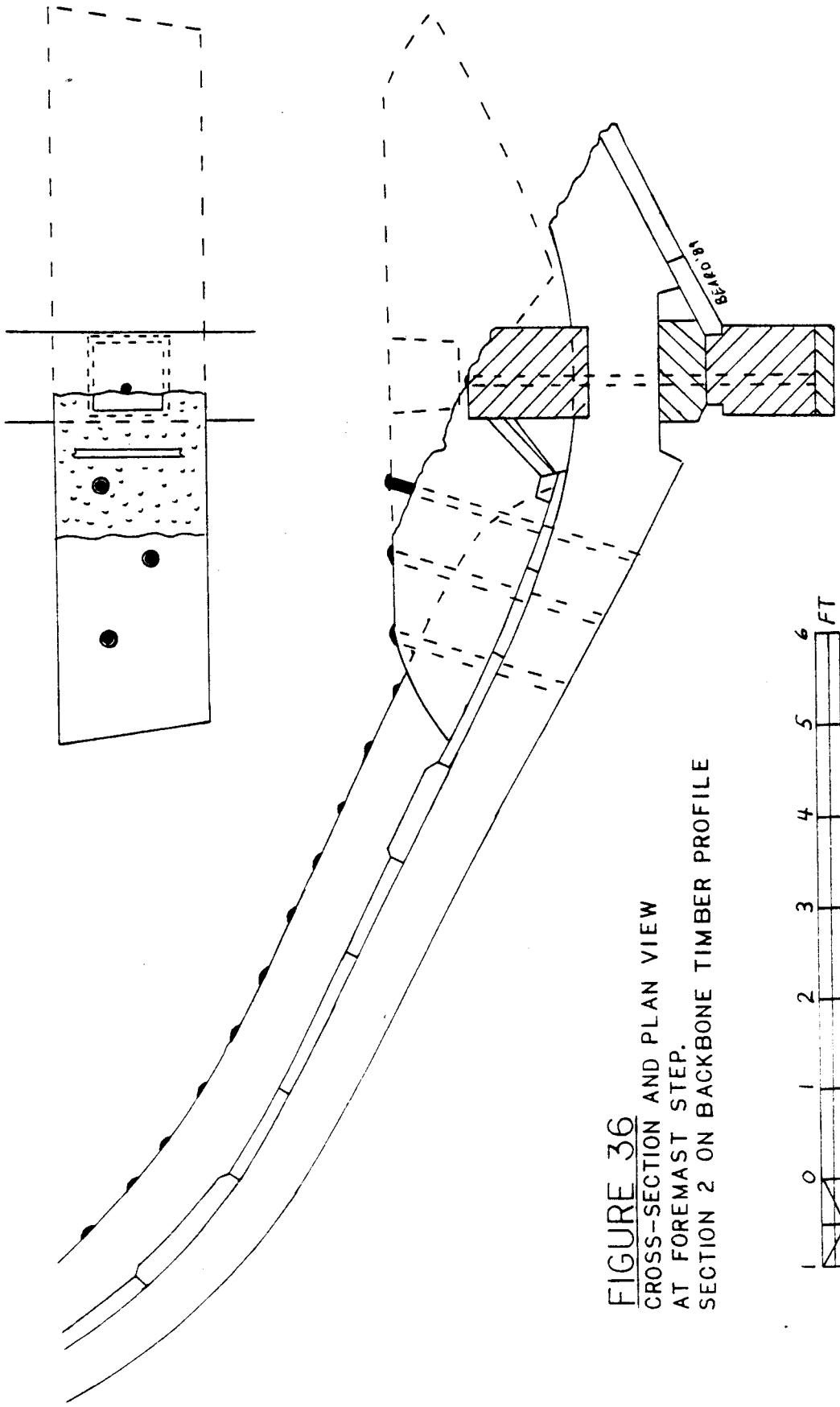
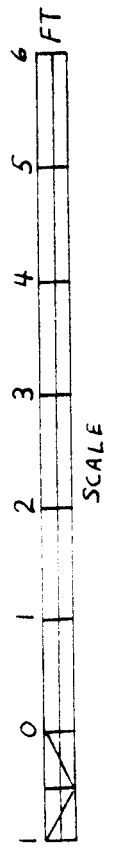

FIGURE 36
 CROSS-SECTION AND PLAN VIEW
 AT FOREMAST STEP.
 SECTION 2 ON BACKBONE TIMBER PROFILE



wedge-shaped crutch or sister timber placed on both sides of this step, just forward of the central lower rider (Figs. 27 & 33). These crutches are similar to those supporting the mainmast step of the American privateer *Defence*, which was scuttled in Penobscot Bay, Maine in 1779 (Figs. 34 & 47b).²⁸

The mainmast step is centered 20 feet, 1 inch forward of the aft end of the keel, and is surrounded by the shot lockers (Figs. 16, 27 & 47a). It is cut from a single piece of oak and is straddles the keelson. Its maximum athwartship dimension is 6 feet, 4 inches. The sided dimension is 1 foot 11-1/4 inches and its maximum molded dimension is 1 foot, 10 inches. It has an octagonal mortice to receive the mast's tenon which is 1 foot, 10 inches long (fore and aft), 1 foot, 3-1/2 inches wide (athwartships) and 6 inches deep.²⁹ Its top edges are chamfered (Fig. 35).

One interesting point about the mainmast step is the absence of fasteners of any kind holding it in place (Fig. 35). It may be that in the event of the mainmast becoming unstepped, as it did on at least one documented occasion during *DeBraak's* career as a brig, it was considered preferable to have the step itself slip out of place as opposed to putting stress on through-hull fasteners which could conceivably rip a hole in the ship's hull. Another equally practical reason for not having through-hull fasteners at this point in the ship's hull is that the constant wiggling of the heel of the mast would eventually cause the vessel to leak around these fasteners.

The foremast step is centered 13 feet, 3 inches aft of the forward end of the keel (Figs. 16 & 27). Like the mainmast step it is cut from a single piece of oak and straddles the keelson. It is 7 feet, 11 inches long (athwartships),

sided 1 foot, 7-1/2 inches, and molded (maximum) one foot, nine and one-half inches. Like the mainmast step, the top edges of the foremast step are chamfered. It was originally fastened into place with six copper drift pins (three survive in a staggered pattern on the starboard side). The mortice for the mast tenon is so badly degraded that no physical data remains. For the purpose of illustration it has been recreated based on the Admiralty drafts (Fig. 36).

Riding Bitt and Bowsprit Step Posts (Pillars)

The basal remnants of one riding bitt post and one bowsprit step post are extant in *DeBraak's* hull. The riding bitts of a sailing ship, also known as cable bitts, are used for the purpose of securing the anchor cables. In a small brig there would be two sets of riding bitts. *DeBraak's* riding bitts were located just aft of each mast (Figs. 12 & 13, pp. 85 & 86). The bowsprit step is the mortice into which the base of the bowsprit is stepped. In *DeBraak's* case, this step is located above the gundeck (Figs. 12 & 13, pp. 85 & 86). Both of these structural features were added to the ship during the refit.

The surviving portion of one riding bitt post is centered 3 feet, 5 inches aft of the foremast step and 11-1/2 inches out from the keelson cheeks (Figs. 27 & 37b). It is 9 inches square and has beaded edges, interesting adornments for such a large utilitarian timber. It has a tenon 8-1/2 inches long, 2-3/4 inches wide and 4 inches deep. The post is stepped between two floor timbers, one of which has been inleted to receive the tenon (Fig. 37a). This will be discussed in more detail in the section on conversion and repair.

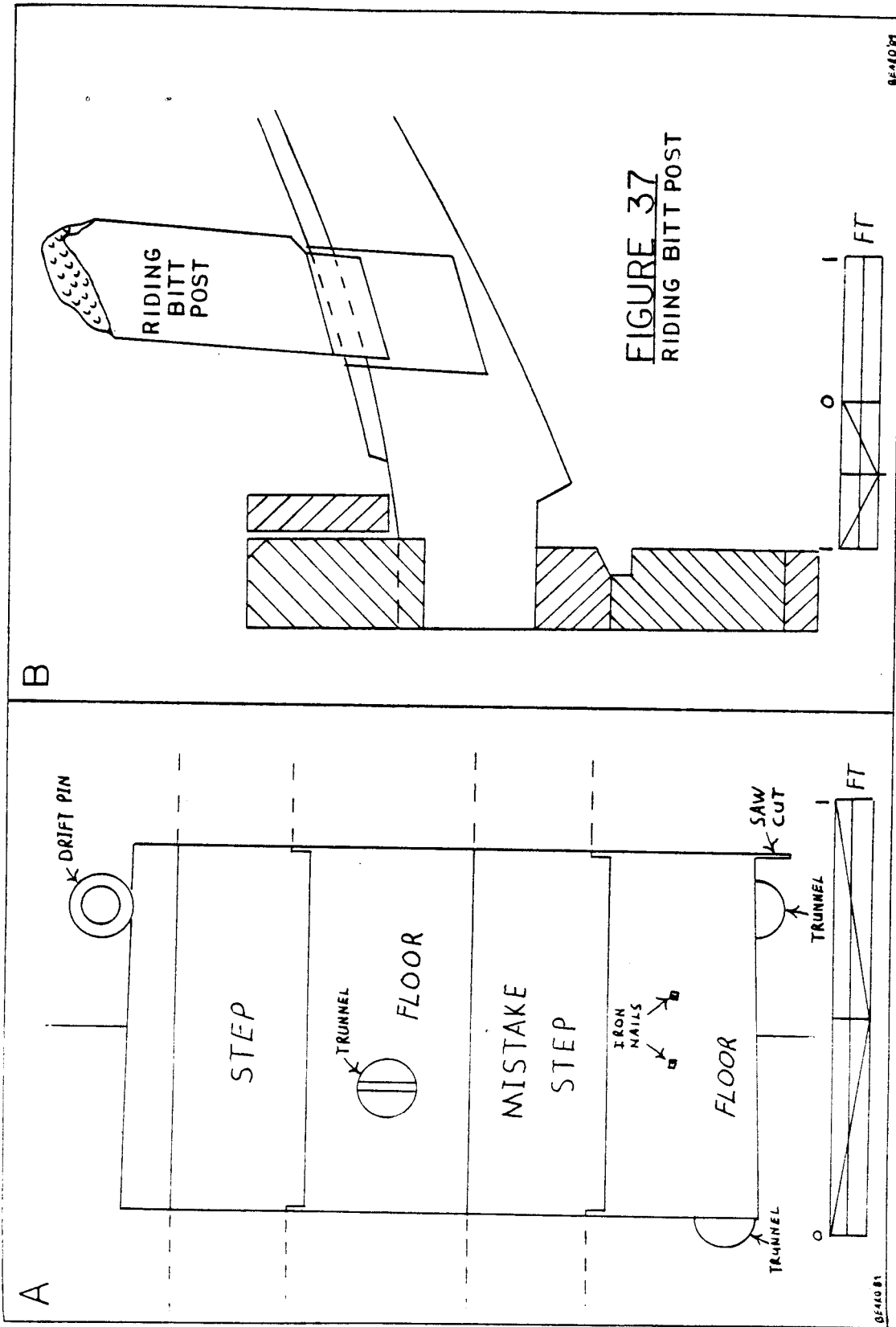
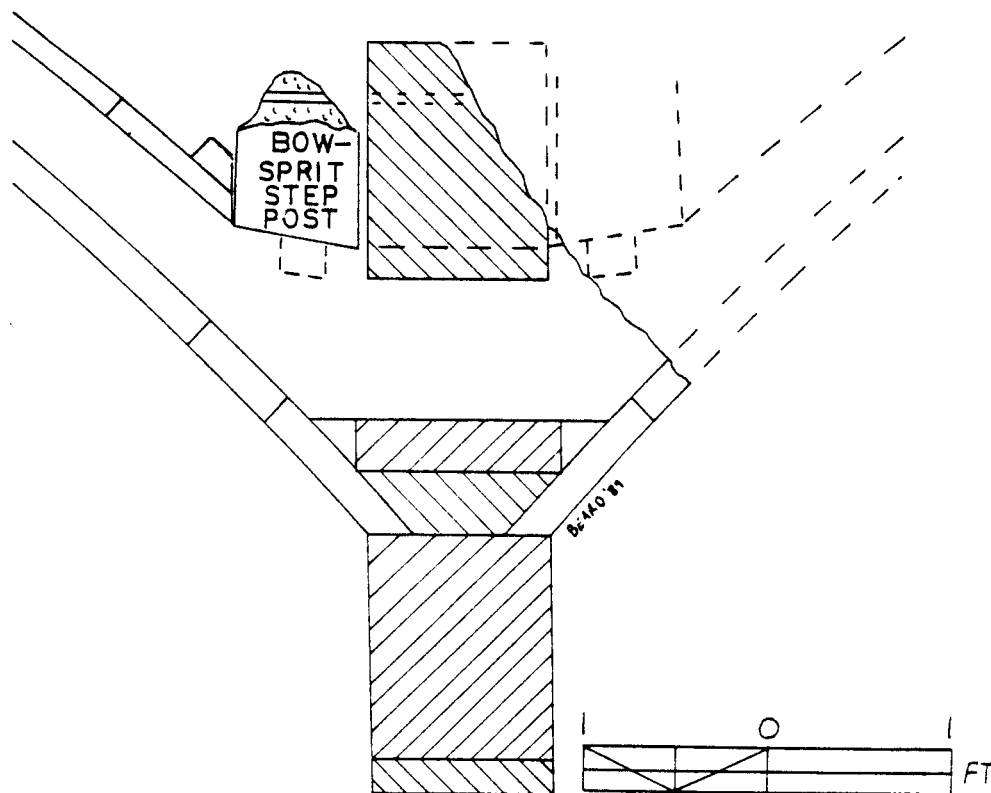
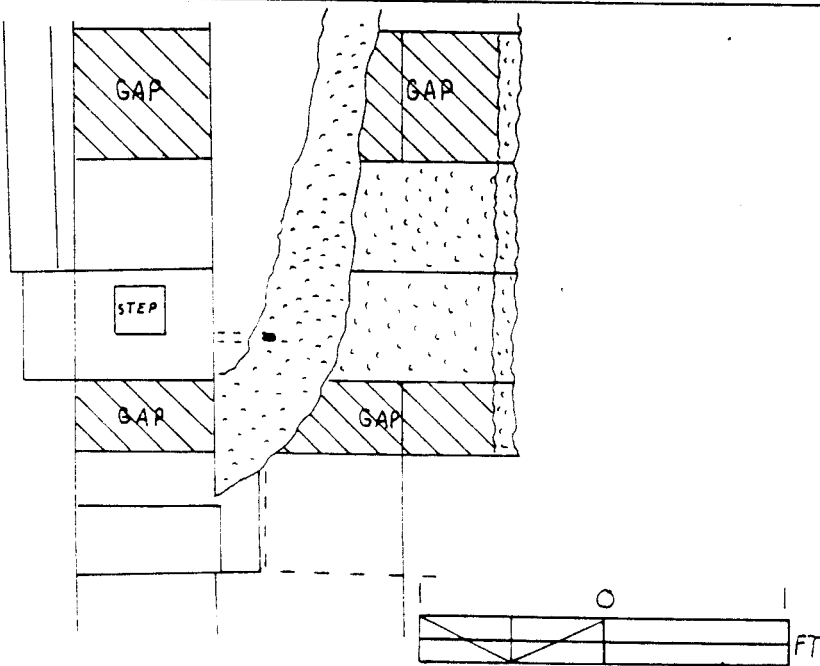

FIGURE 38: BOWSPRIT STEP POST



A SECTION I ON BACKBONE TIMBER PROFILE

B
PLAN
VIEW



BEAKO 89

The base of the bowsprit step post is centered 3 feet, 4 inches forward of the foremast step, and against the side of the keelson. It is 8 inches square and, like the riding bitt post, has a beaded edge. The tenon on this post is 3 inches square and 2-3/4 inches deep, and is stepped into frame 11 (Figs. 27 & 38 a & b).

Limber Boards

DeBraak, like many other wooden sailing vessels of the period, had a series of limber boards, which could be removed in order to clean debris from the bilge and limber holes. Many ships had special limber strakes, which was the first ceiling plank out from the keelson. The limber strake often had a rabbet cut into it to receive the base of the limber boards (Fig. 39b). There is no limber strake as such in *DeBraak*. Instead, a specially shaped "retainer plank" nailed to the first ceiling plank holds the limber boards in place (Fig. 39a).

Along the starboard side the limber boards average 12 inches wide (Fig. 40). In profile most have a truncated triangle shape, although some have two-sided points, and average 1-1/2 inches thick (Fig. 41). The height of the limber boards varies depending upon the curvature of the hull.

The port side limber boards are somewhat different. Each board is longer, averaging between 16 and 18 inches. Roman numerals have been carved into the boards, overlapping the seams between them, presumably to allow them to be placed back in their proper order. The letter "L" is also cut into several of these boards and may stand for "Larboard," another word for port or as an indication that these were limber boards and not to be thrown out

FIGURE 39

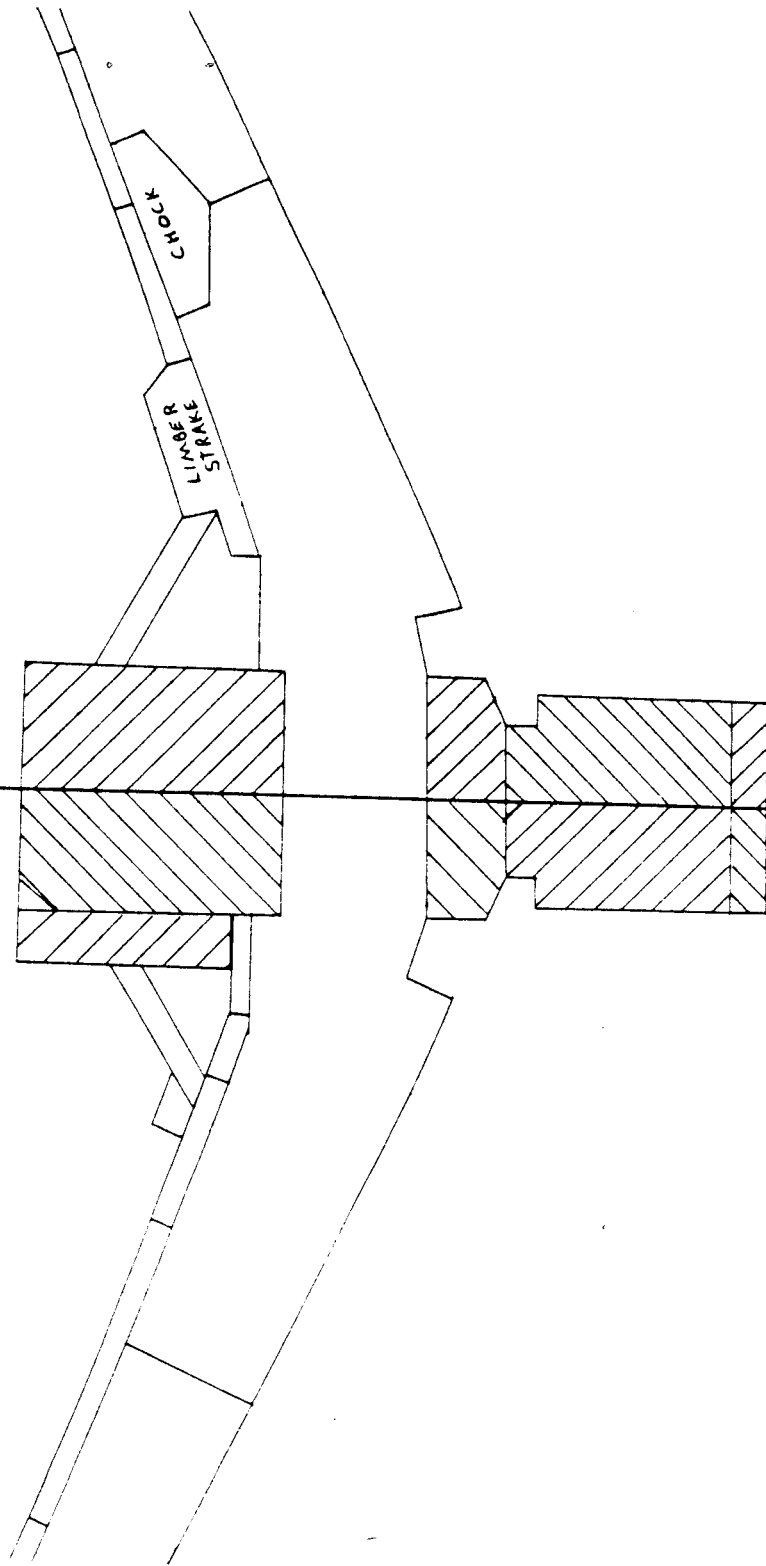

A DEBRAAK'S LIMBER BOARD RETAINER STRAKE B RABBETED LIMBER STRAKE

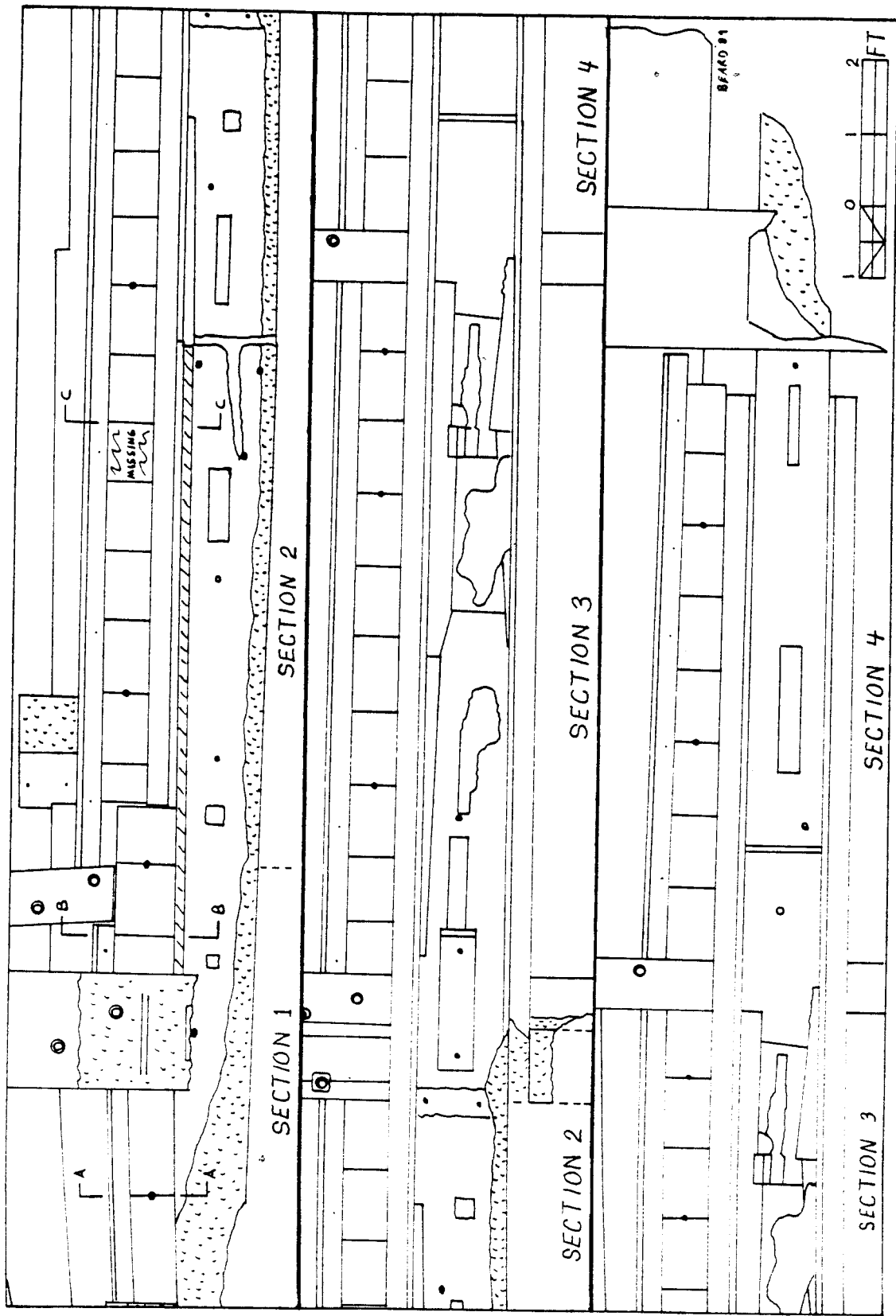
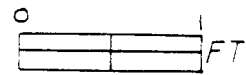
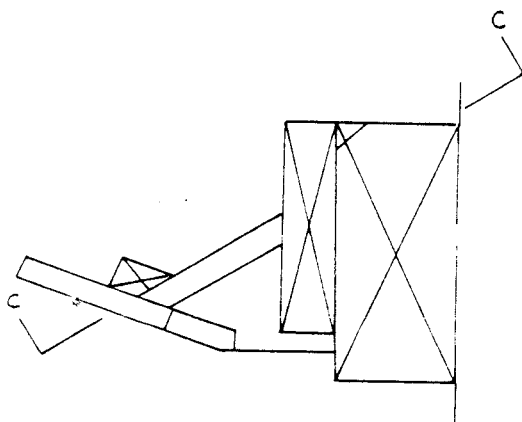
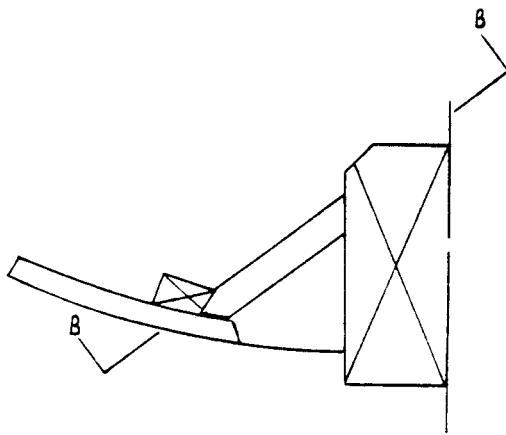
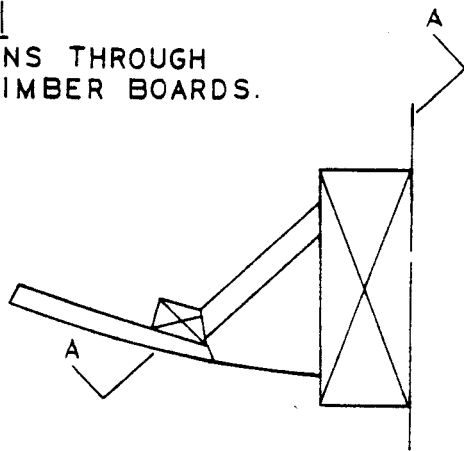

FIGURE 40: PLAN VIEW OF KEELSON AND STARBOARD SIDE LIMBER BOARDS

FIGURE 41
CROSS-SECTIONS THROUGH
STARBOARD LIMBER BOARDS.
(SEE FIG. 40)



BEARD 21

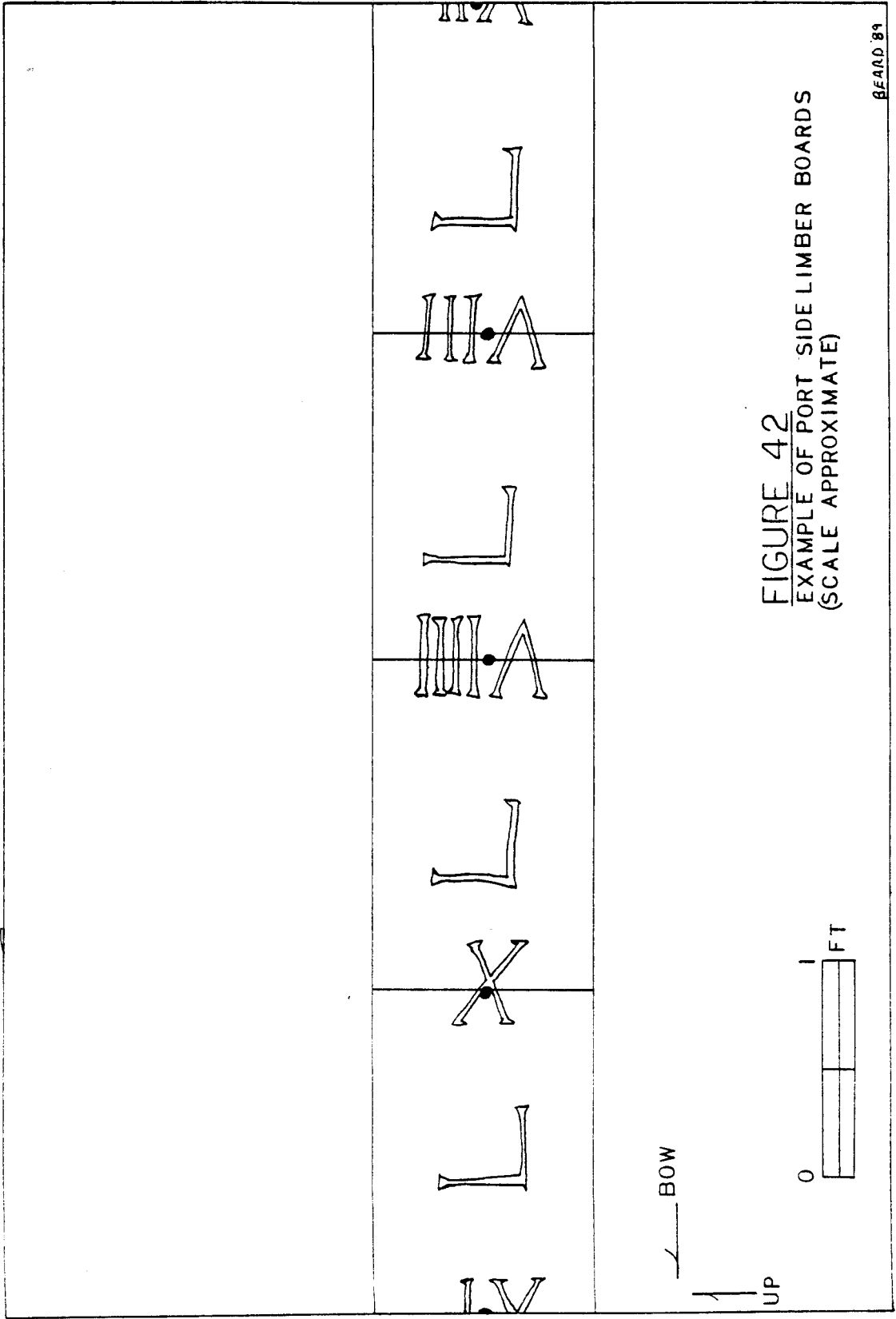

FIGURE 42
 EXAMPLE OF PORT SIDE LIMBER BOARDS
 (SCALE APPROXIMATE)

when the ship was rummaged (Fig. 42). The limber boards on both sides have holes drilled at certain seams between them. This is presumably to allow a finger or special tool to be inserted for easier removal (Figs. 40 & 42).

Bulkheads and Partitioning

Mapping of *DeBraak's* hull prior to its recovery identified a series of interior partitions, running both fore and aft and athwartships, which were subsequently lost during the salvage operations (Fig. 43). Only one of these, the forward bulkhead, could be identified from the Admiralty drafts. The others were most likely constructed by ships' carpenters after the refit for the purpose of stowage and securing cargo and stores. These structures would have been of particular interest to marine archeologists and historians since little information about them is available. Unfortunately, only the most basic descriptions of these structures can be supplied on the basis of the fragmentary data available.

The remains of the forward bulkhead have been partially reconstructed by the "jigsaw puzzle" method described in an earlier chapter. It was constructed of a series of horizontal red pine strakes, ranging from 7-1/2 to 9 inches wide, which were fitted together with a half lap or "ship lap" rabbet.³⁰ These strakes are generally 1-1/4 inches thick (Fig. 44). The bulkhead was held up by a set of vertical stanchions. A number of stanchion fragments were recovered during the salvage, but at this time none have been positively matched with the surviving bulkheads.

What can be determined about the rest of the lost partitioning is that it consisted of longitudinal stringers and pine planking. At least some of the

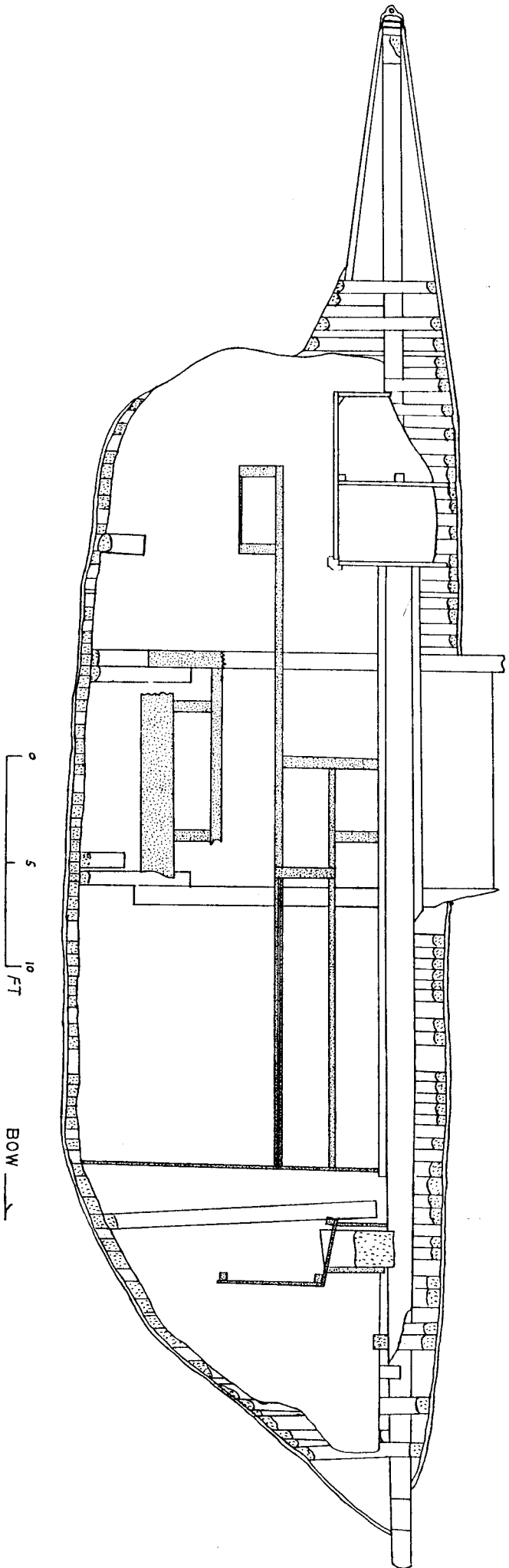
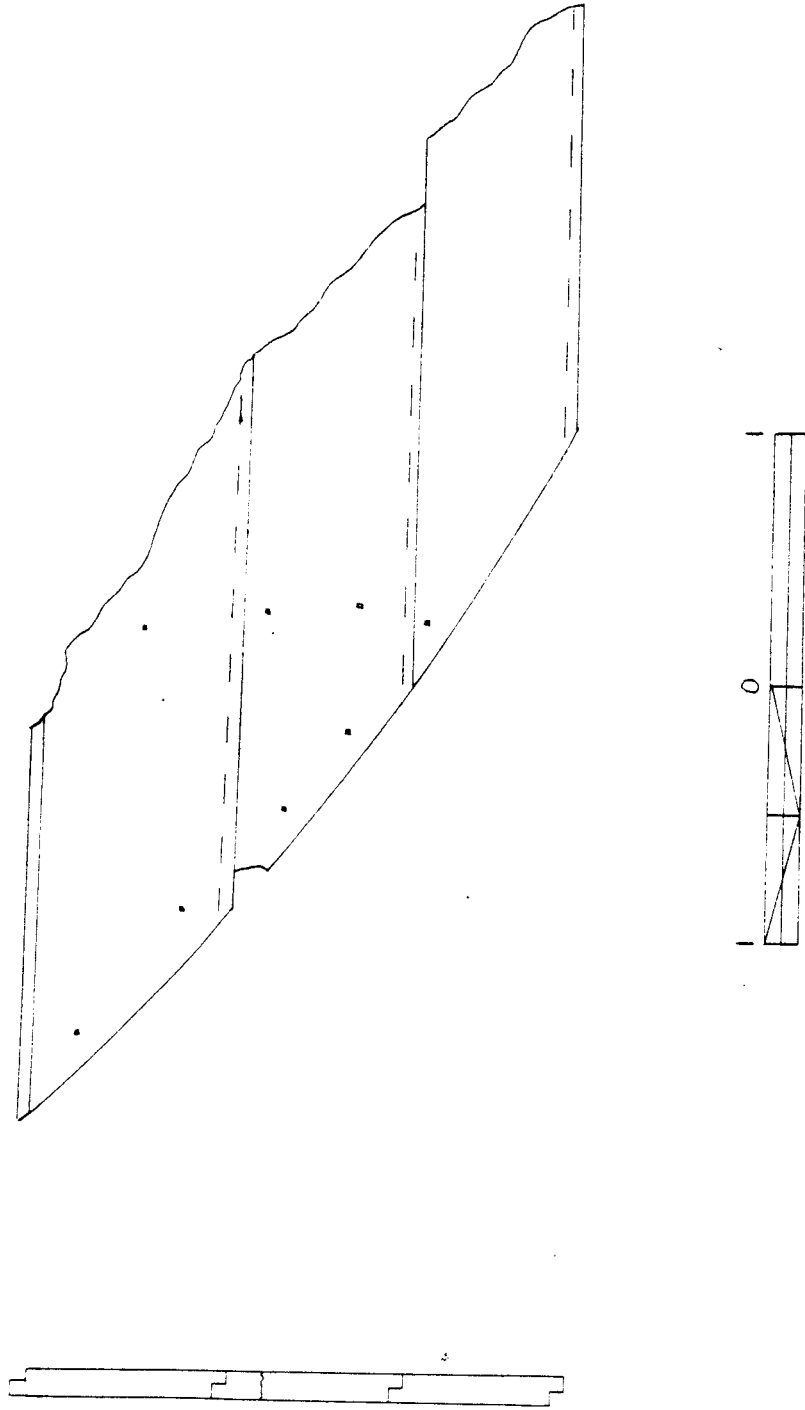
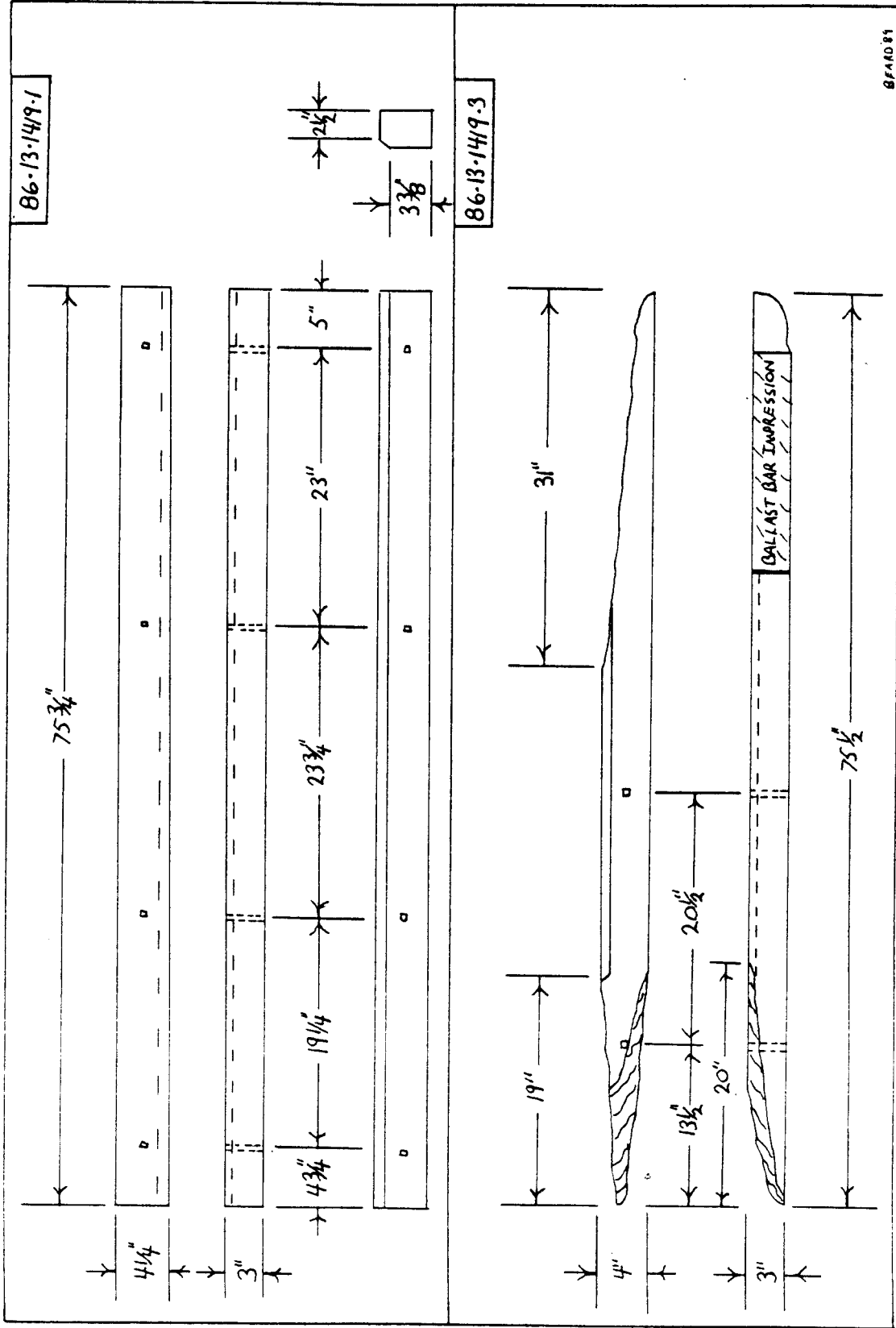

FIGURE 43: SIMPLIFIED SITE PLAN SHOWING LOST TIMBERS

FIGURE 44
RECONSTRUCTED FORWARD ATHWARTSHIP BULKHEAD SECTION



BEARD '85



86-13-1419-1

86-13-1419-3

FIGURE 45. HOLD STRINGERS

stringers ran along the surface of the ceiling planks, as is evidenced by the concreted impression of a ballast bar on the side of one of them (Fig. 45). While much of this timber was heavily concreted when mapped, making recording difficult, in one spot it was apparent that the upright planking consisted of two parallel planks divided by upright fillers (Fig. 43). The height of these structures is impossible to determine from the data available.

Hold Platform

Based on data collected from the hull prior to its recovery and the presence of a series of mortices cut into the starboard ceiling planking (Fig. 27), a platform of some sort ran almost the entire length of *DeBraak's* hold approximately 3 feet, 6 inches below the lower deck. No structure of this sort appears on the Admiralty drafts.

The athwartship beams of this platform are sided approximately 8 inches and molded 7 inches. The mortices in the ceiling planks line up with mortices in the keelson, indicating that these beams may have extended across the entire width of the hold (Fig. 27). It cannot be determined if the pine planking of this platform also extended from side to side. There may have been an open passage down the length of the keelson to allow access to stores and the bilge. Figure 46 is a cross-sectional reconstruction of what this platform may have looked like.

Shot Lockers

Despite the shock and trauma received by *DeBraak's* hull when it was lifted, part of the shot lockers, with a large number of shot *in-situ* remained

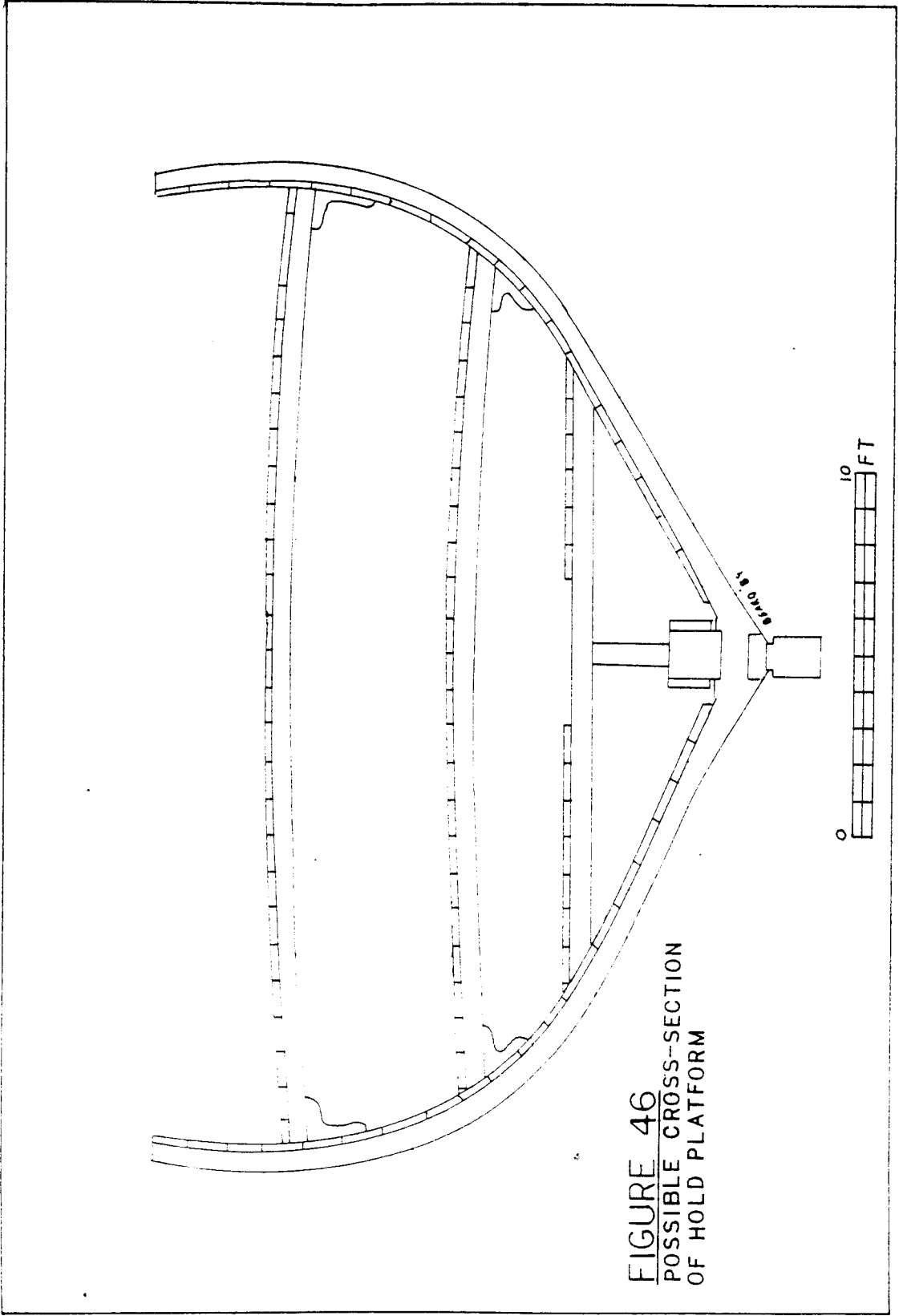
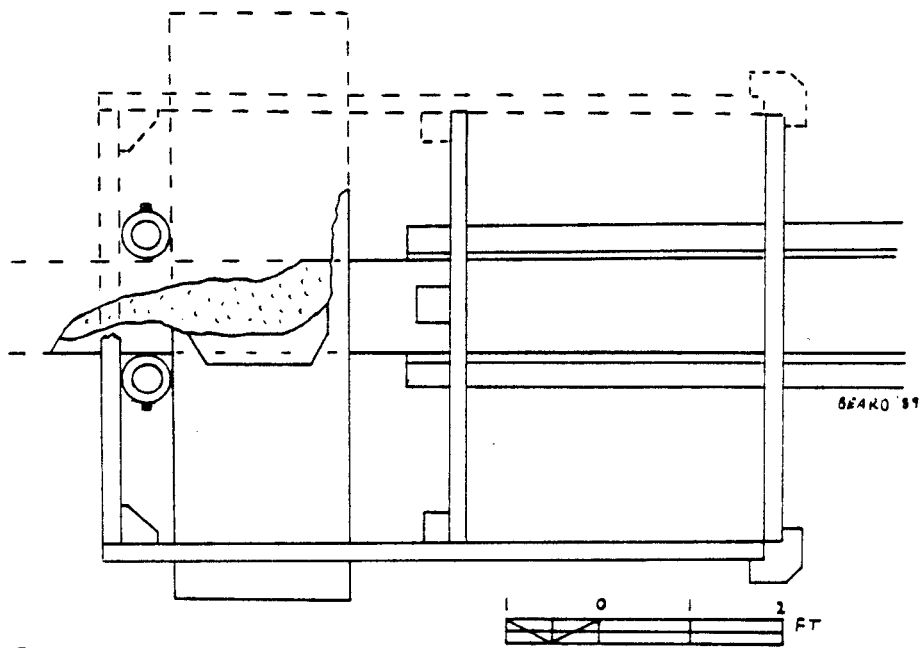
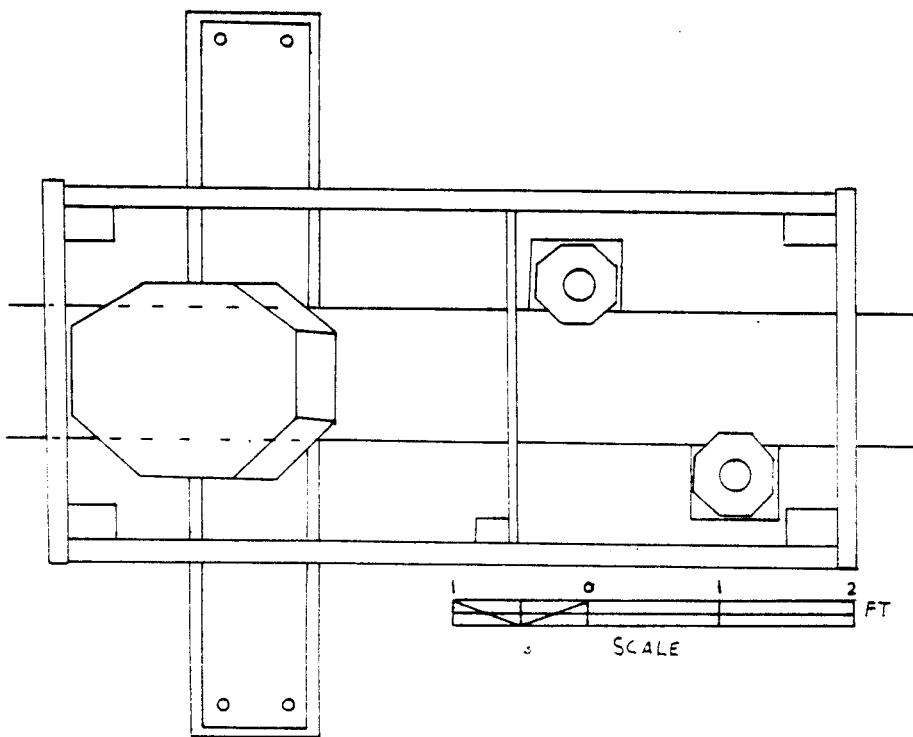

FIGURE 47: PLAN VIEW OF SHOT LOCKERS



A DEBRAAK



B DEFENSE (REDRAWN COURTESY OF DAVID SWITZER)

FIGURE 48
PROFILE OF DEBRAAK SHOT LOCKERS

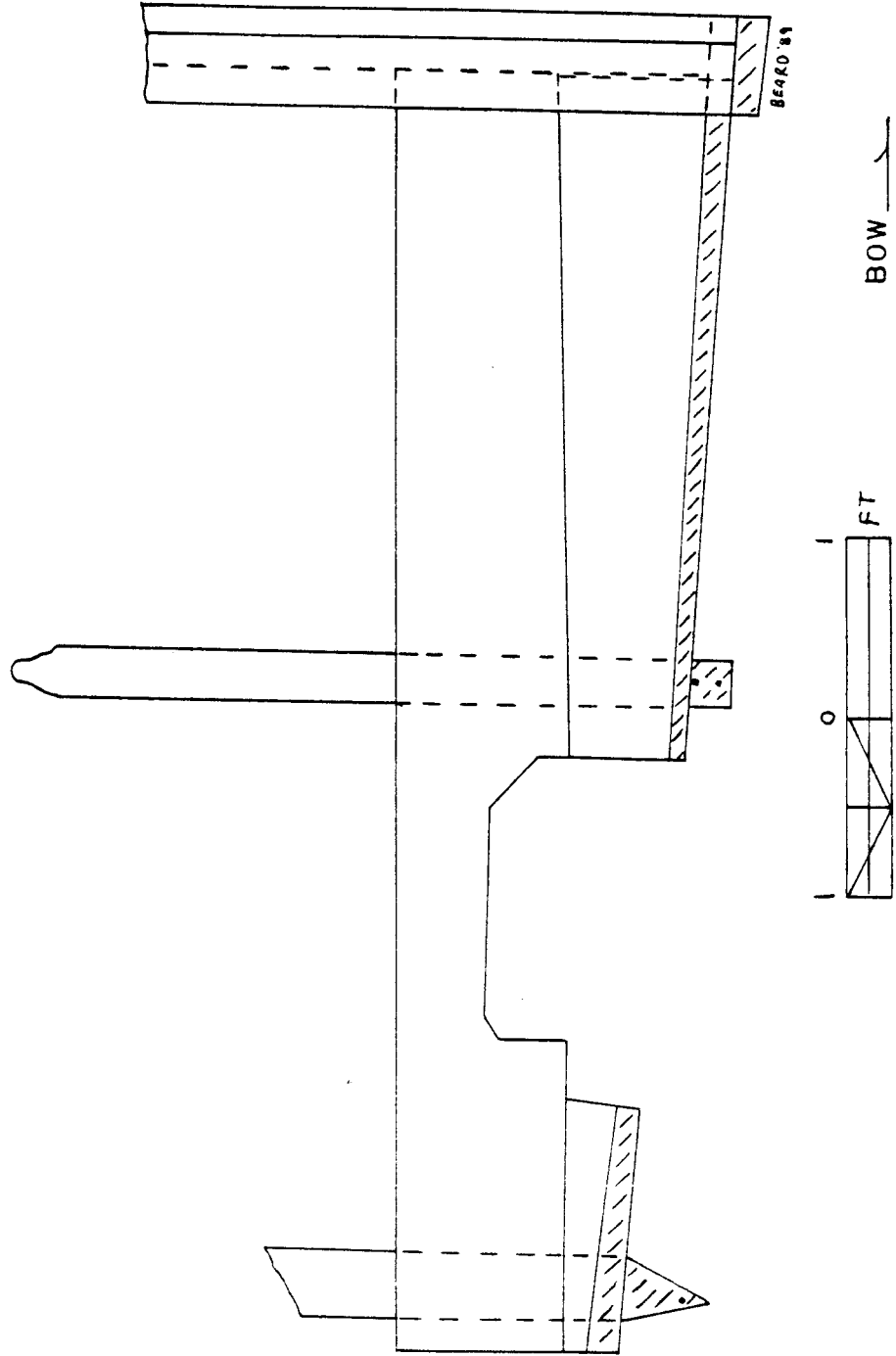

FIGURE 49. ATHWARTSHIP SECTIONS: DEBRAAK SHOT LOCKER

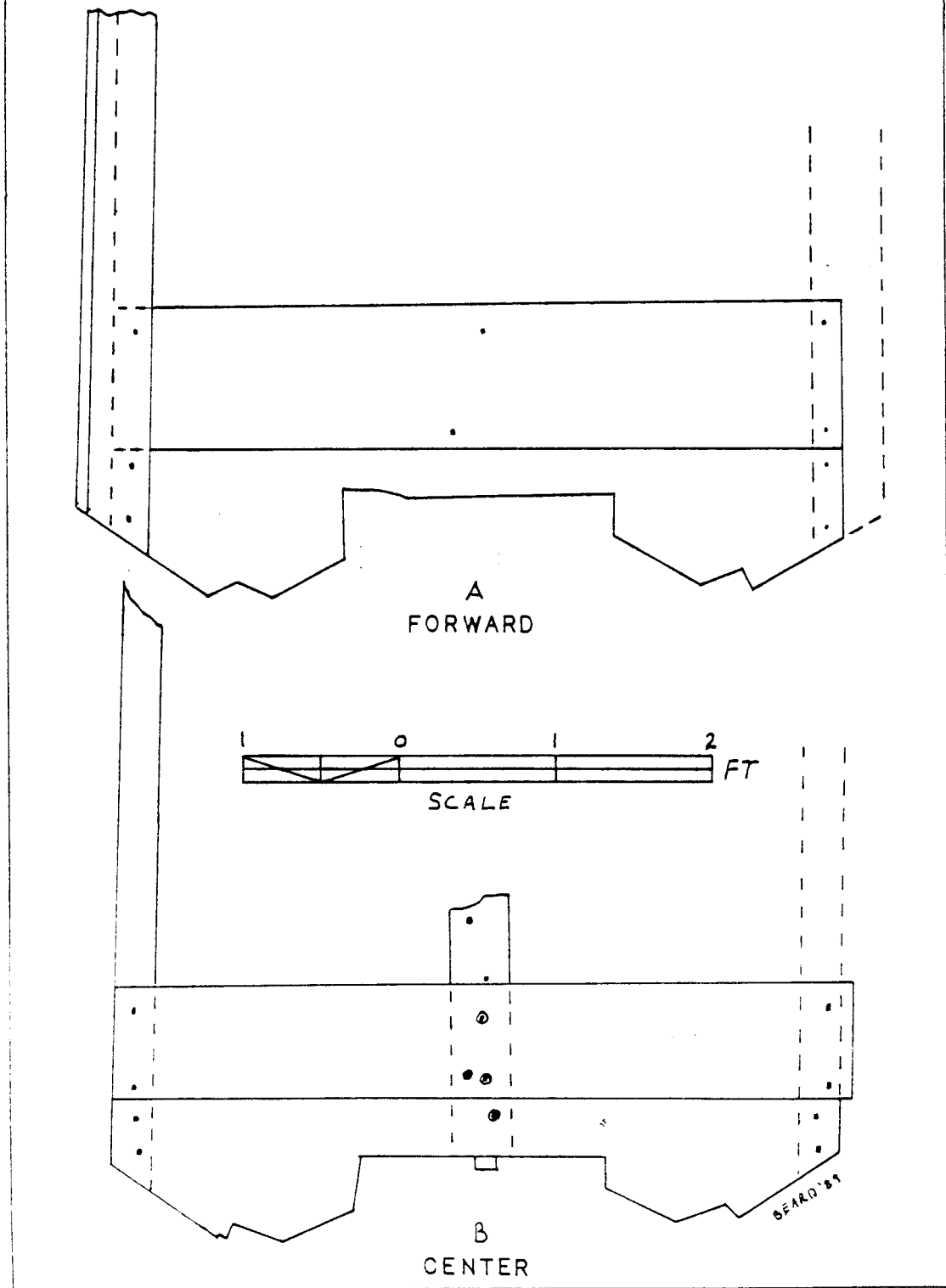
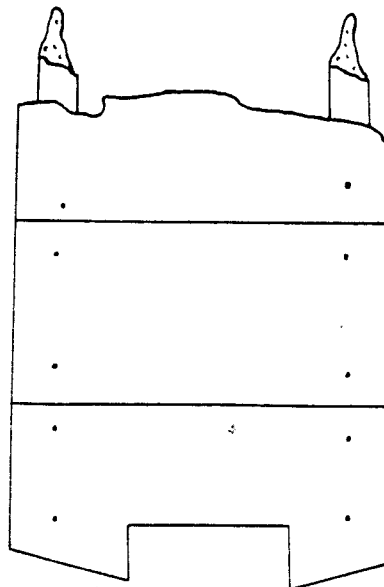
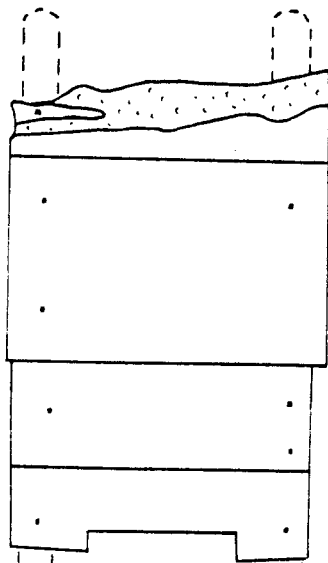
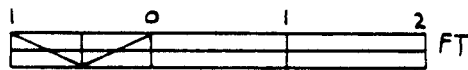
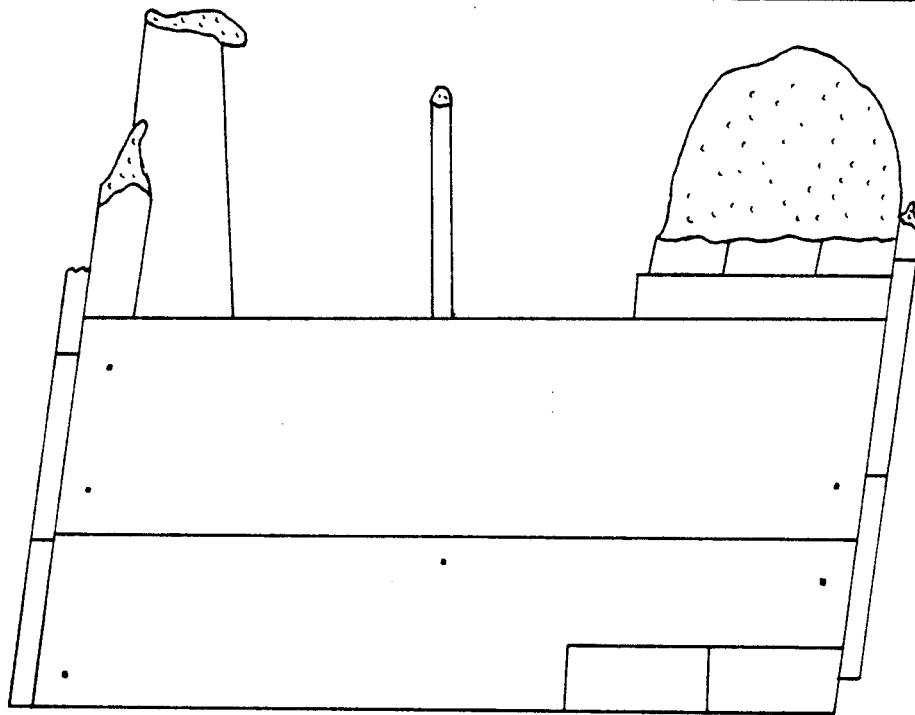

FIGURE 50: PROFILE AND ATHWARTSHIP SECTIONS OF DEFENSE SHOT LOCKERS



(REDRAWN COURTESY OF DAVID SWITZER)

concreted to the hull. However, much of the shot and a number of planks were lost and only a few of the latter have been rearticulated with the rest of the locker.

Once the shot for the 24-pounder carronades was removed it was found that the shot lockers surrounded both the mainmast step and the bases of the bilge pump tubes. The shot locker has two separate sections to the shot locker, one measuring 3 feet, 2-1/2 inches fore and aft by 4 feet, 8 inches athwartship (inside dimensions), and another measuring 3 feet, 6-1/2 inches by 4 feet, 8 inches (Figs. 27 & 47a).

The planks are also made of red pine and average 2-1/4 inches thick. The lower-most planks on the surviving starboard side of the shot locker diminish in width with the run aft of the hull. One long plank is inlet to straddle over the mainmast step (Fig. 48). The lower-most athwartship planks are cut to fit over the keelson and conform to the shape of the limber boards, limber board retainer and the contour of the hull (Fig. 49). This arrangement is also similar to the shot lockers of *Defence* (Figs. 47b & 50).³¹

Four surviving stanchions are associated with the shot lockers. Three are from corners formed by the lockers along the starboard side, and one is stepped into the keelson. The starboard stanchions are set into shallow mortices cut into the ceiling planks. In section the stanchions are all different (Fig. 47a). The entire complex was fastened together with 1/4 inch square iron nails, which have totally oxidized.

Firehearth Pit Liner

A large lead sheet was recovered from *DeBraak's* hull which for some

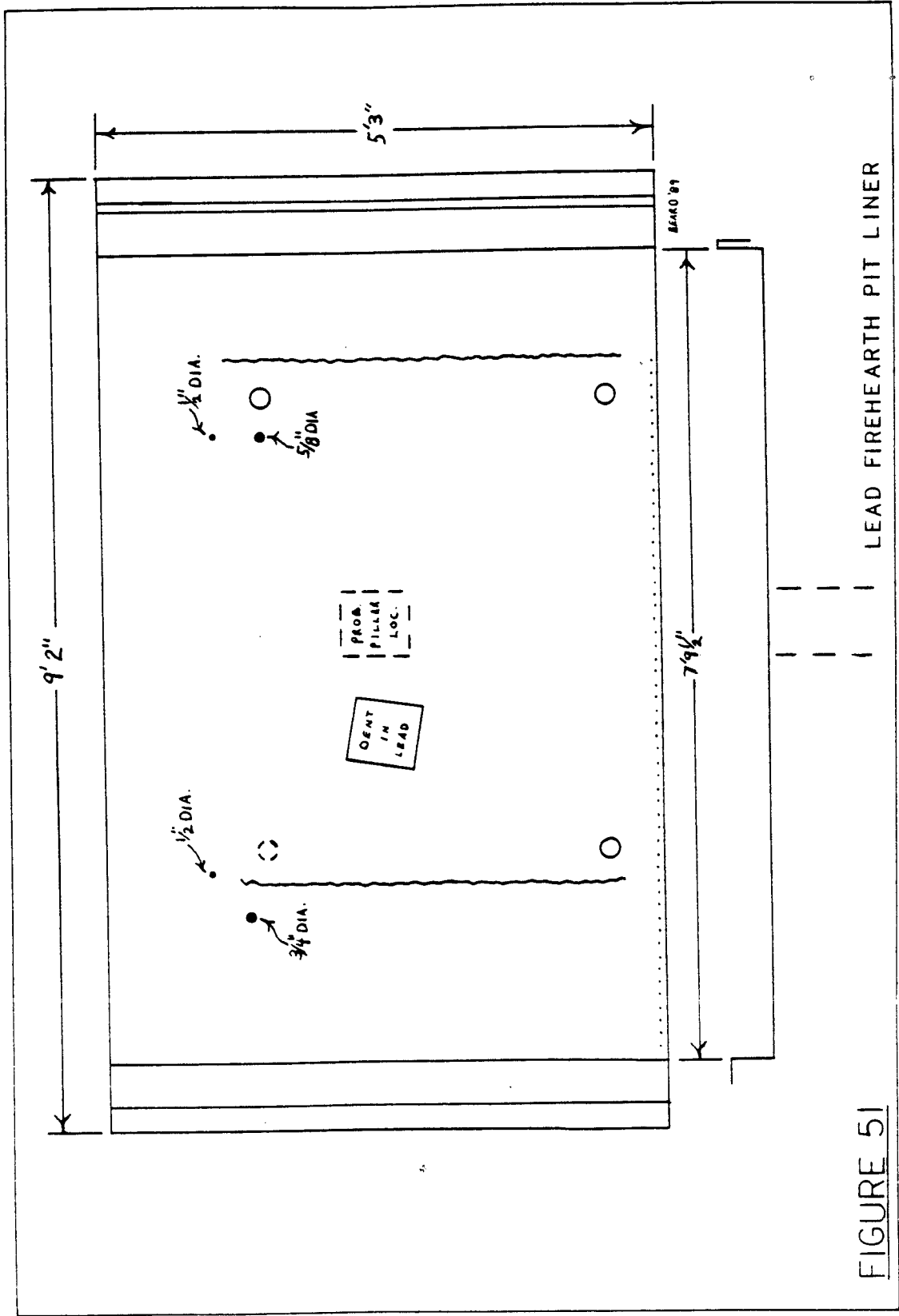

LEAD FIREHEARTH PIT LINER

FIGURE 5J

time was a mystery to researchers. It was crumpled when recovered and was at first thought to have been the lining for the powder magazine. This theory was fairly weak due to the fact that the lead sheet was located just aft of the foremast step.

Once the tedious task of flattening out this lead was completed (there was the risk of it cracking along any of the many bent seams) a clearer picture of its probable function emerged. The sheet was rectangular and measured 9 feet, 2 inches by 5 feet, 3 inches and was 1/8 of an inch thick. There was no indication that it had been shaped at the angles that would be expected for the magazine liner, although the ends had obviously been shaped over timbers (Fig. 51).

There were iron-oxide concretion lines forming a rectangle in the center of this sheet, and near three of the corners formed by these lines were round indentations 2-1/2 inches in diameter. Offset from the center of the sheet was a 7-1/2 inches square indentation, pushed from the opposite side from the circular indentations. Along one of the sheet's long sides there are 54 nail holes, which are spaced approximately 1-1/2 inches on centers.

On the basis of the size of this sheet of lead, its location within the hull, and the indentations on its surface, it was determined that it had served as a liner for the firehearth pit, a recessed section of the lower deck into which a "Brodie Patent" cast iron stove had been installed (Fig. 12). The ferrous concretion lines suggest that this stove measured approximately 5 feet long by 3 feet, 8 inches wide. The round indentations were made by tubular ceramic "feet" attached to the bottom of the stove. These ceramic feet possibly served to keep the heat of the stove from being transmitted to the

lead. The square indentation was likely made when the pit collapsed after being devoured by toredo worms, causing the support stantion to push into it. Figure 51 illustrates the reconstructed lead sheet and the shape of its attachment to the deck.

Bilge Pumps

The lower ends of both bilge pump tubes are extant in *DeBraak's* hull. These tubes are simply hollowed out elm logs, inside which the mechanisms for the suction pumps operated. Although no detailed analysis of the pump mechanism itself will be discussed in this section, a general description of their workings is called for.

DeBraak's pumps were of the two-stage suction type. They consisted of a system of piston rods, lift buckets and flapper valves, which allowed water to be brought up from the bilge via suction and discharged on the upper deck. Larger vessels used chain pumps, in which the water was forced up by the continuous motion of a chain fitted with evenly spaced disc shaped segments. These discs formed a seal with the side of the pump tube in order to carry the water to an upper deck from which it would then be channeled out of the ship. The suction pumps were operated by hand on the gundeck; they consisted of two turned bronze tubes (chambers) and a rocker mechanism.³²

The outside diameter of the elm tubes at their bases is 7-7/8 inches (the diameter diminishes from top to bottom) and the inside diameter is 4 inches. They are "L" shaped in profile at their bases, so the tubes set against the

FIGURE 52: BASE OF PORT BILGE PUMP TUBE

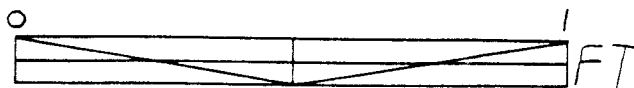
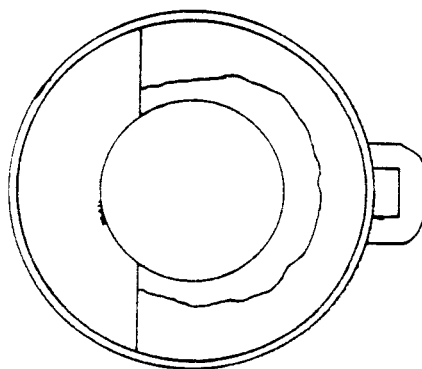
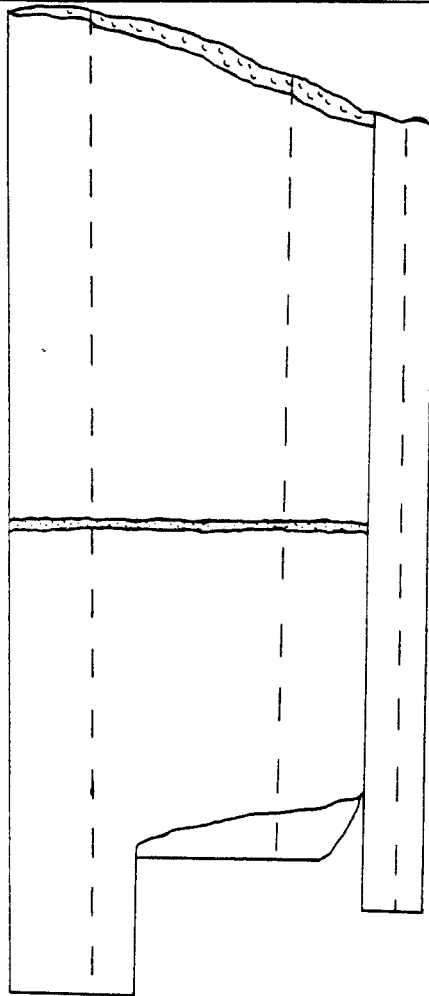
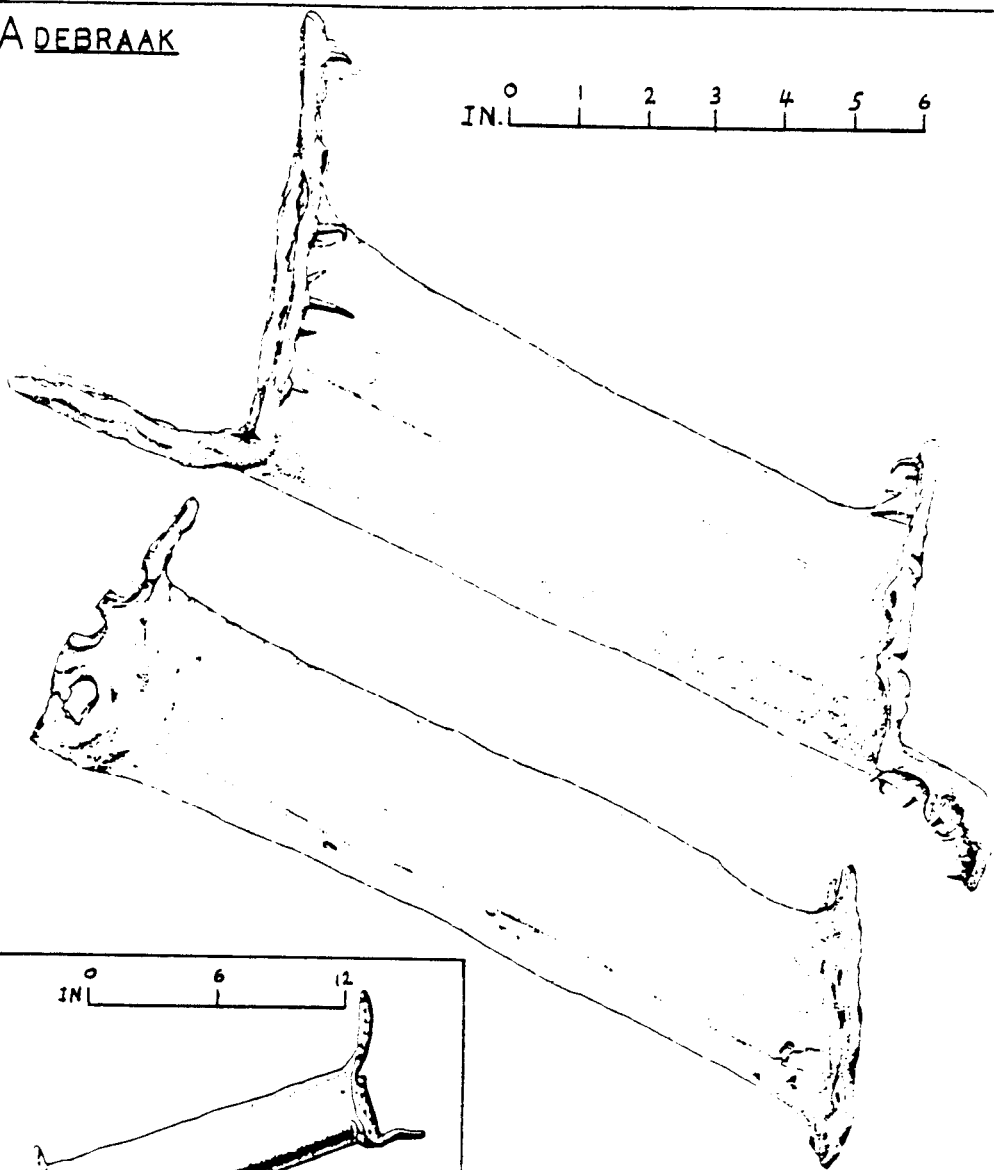

FIGURE 53: SCUPPERS

A DEBRAAK

IN. 0 1 2 3 4 5 6



IN. 0 6 12

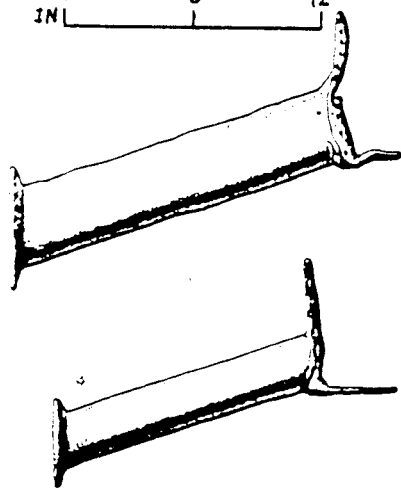

B DARTMOUTH, 1655
(FROM GOODWIN, p. 66)

(DRAWING BY WALT LENNINGTON)

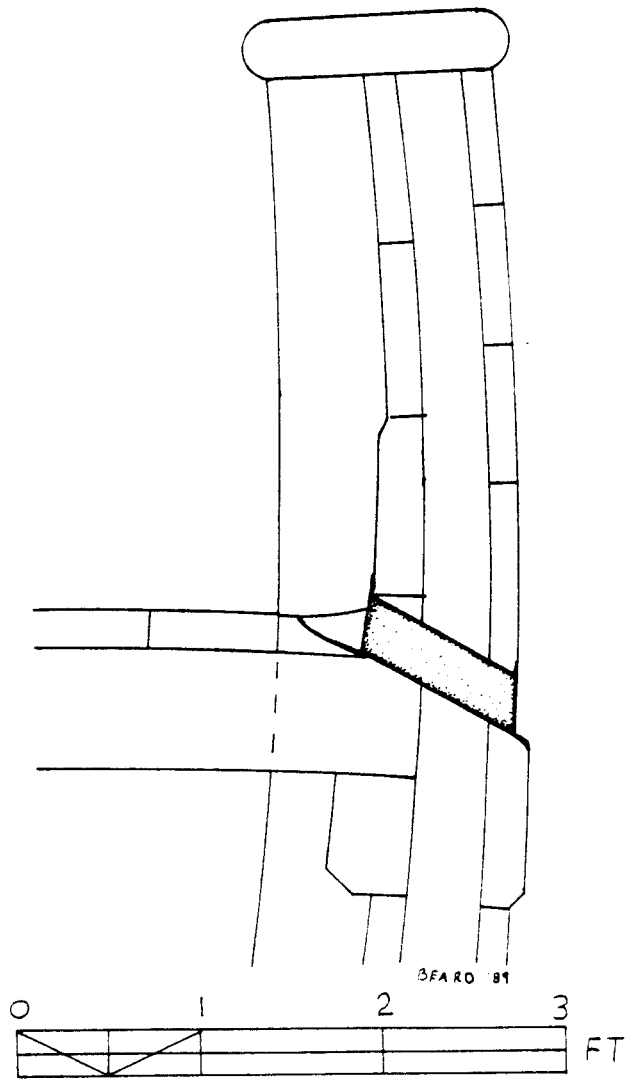

FIGURE 54: POSSIBLE ATTACHMENT FOR DEBRAAK SCUPPERS

rising wood without blocking them (Figs.35 & 52). Except for their arrangement, *DeBraak's* pumps are also similar to those found in *Defence* (Fig. 47b).³³

An interesting feature of the tubes is the presence of smaller "U" shaped tubes running down their outboard sides. Their function has not been definitely determined, but they may be the guides for some sort of mechanism for clearing the base of the pump of debris without a man having to enter the bilge (Fig. 52).

Associated with the bilge pumps are the ship's scupper pipes. A ship's scuppers are drain pipes that allow water to run off the decks. Two types of large lead scupper pipes (two of each type) have been recovered from *DeBraak's* wreck site (Fig. 53a). These are similar to scupper pipes recovered from the wreck of H.M.S. *Dartmouth*, a ship launched in 1655. The similarity between the scuppers recovered from these two shipwrecks suggests that there was little change in form during the intervening century (Fig. 53b).³⁴ Figure 54 illustrates the likely method in which *DeBraak's* scuppers pierced her hull.

Capstan

Three surviving structural elements which are parts of *DeBraak's* capstan: the base of the spindle, the spindle socket and a fragment of the top of the spindle where it fitted into the barrel or main part of the capstan. The spindle appears to have had an iron band around its base in order to reduce wear. This band was fastened to the spindle with four iron spikes. There is also the remains of an iron washer on the bottom of the socket, also possibly

to reduce wear and friction.

The socket also appears to have had an iron "sleeve" into which the spindle was set. Besides reducing wear, these iron furnishings may have facilitated the lubrication of the apparatus in order to insure smooth turning of the capstan. When recovered the spindle was still in the socket.

Finally, there is what appears to be the top of the spindle. The surviving curved face of this piece indicates it was originally a round timber approximately 16 inches in diameter. Based on the Admiralty drafts of *DeBraak* "as fitted," the above dimension approximates very closely the top of the capstan spindle where it fits into the barrel. This timber is also partially preserved by the iron oxides that have penetrated it from a wide iron band that formerly encircled it. Its location is illustrated in Figure 15, along with the other pieces of the capstan after superimposition over the Admiralty draft.

Rudder and Associated Fittings

Two major pieces of *DeBraak's* rudder have survived. Most of the base of the rudder was still fastened to the hull with the first pintle in place through the first gudgeon (brace). A section between and including the second and third pintles was recovered near the stern. The surviving pieces and the Admiralty drafts suggest that the rudder was constructed of four main pieces, excluding the bearding and the false heel.

The rudder is 5 inches wide at its bottom, but gets wider toward the top. The main piece where it accepts the tiller is 10-1/2 inches wide. The sided dimension at the top of the rudder is 11-1/2 inches (Fig. 55).

FIGURE 55
RUDDER
RECONSTRUCTION

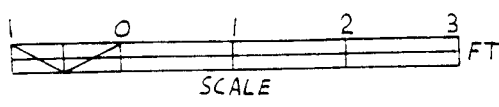
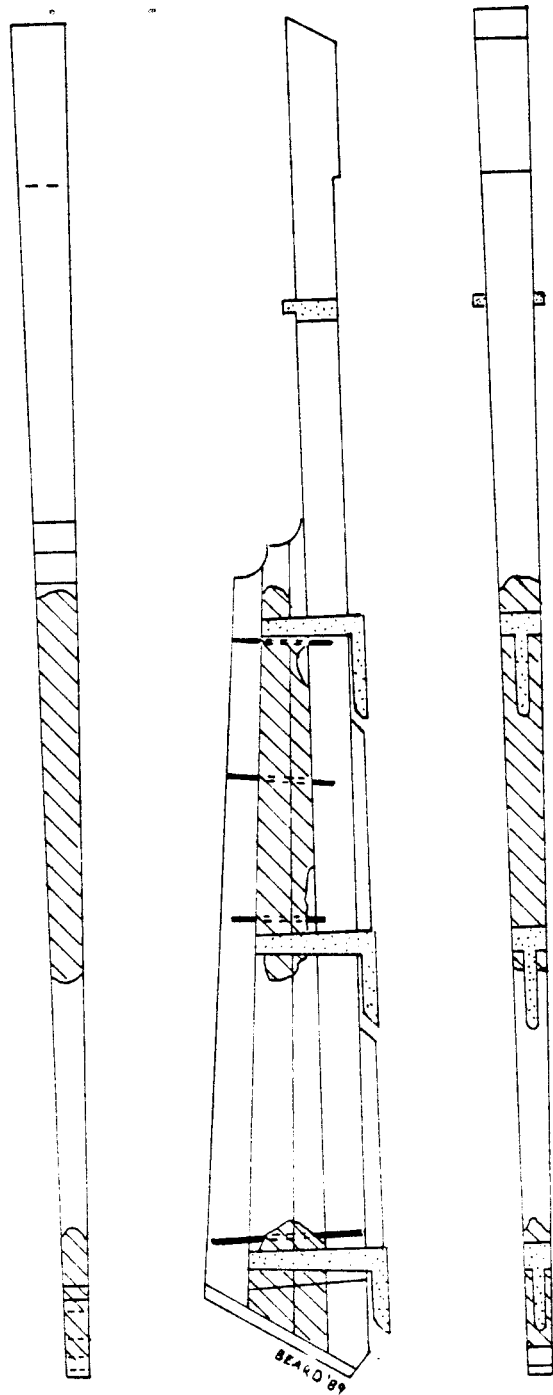

EXTANT
WOOD

FIGURE 56: RUDDER FITTINGS

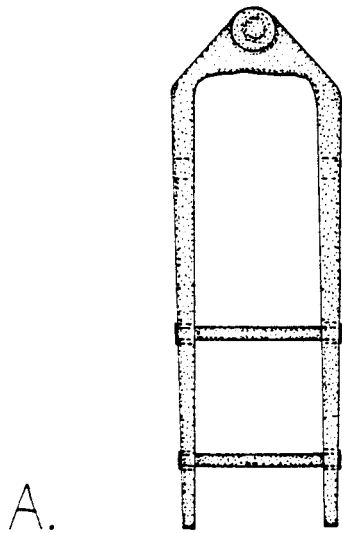

A.

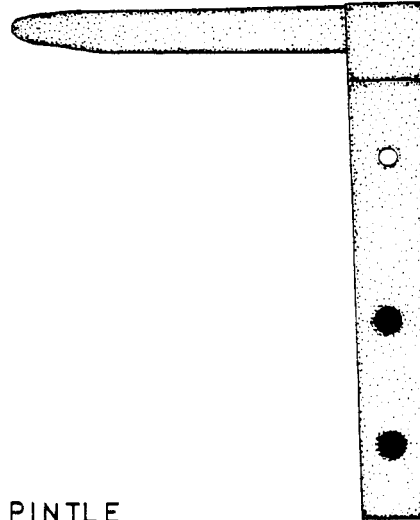

PINTLE

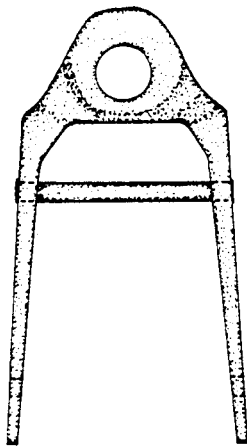

B.

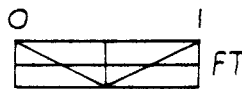

GUDGEON

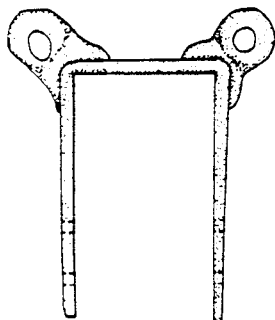

C.

SPECTACLE PLATE

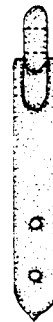

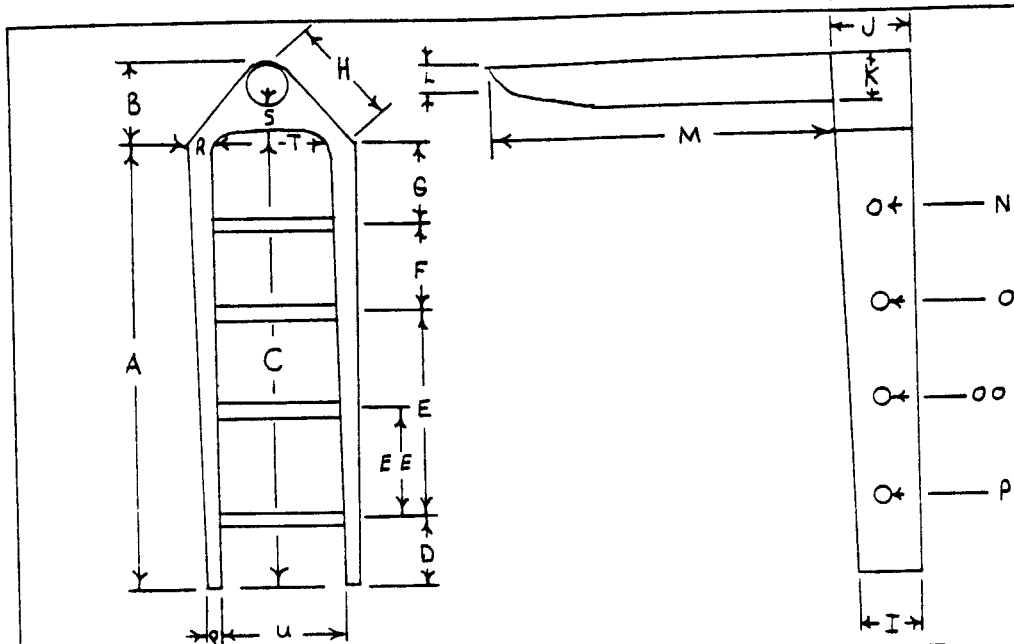

	BOTTOM	MIDDLE	TOP
A	20 5/8"	19 1/8"	15 3/4"
B	2"	3 3/4"	4 3/4"
C	NO DATA	19 7/8"	16 1/2"
D	3 1/2"	3"	2 1/4"
E	5 1/4"	5 1/2"	5"
F	4 3/4"	7 1/4"	5 7/8"
G	3 3/4"	3 1/2"	2 5/8"
H	3 3/4"	5 1/2"	6 1/2"
I	2 5/8"	2 3/4"	3"
J	3 3/4"	3 3/8"	3 1/2"
K	2"	2"	2"
L	N/A	1 1/4"	1 1/4"
M	13 3/4"	14 1/8"	13 1/4"
N	1" HEAD DIA.	7/8" HOLE DIA.	7/8" HOLE DIA.
O	1" HEAD DIA.	1 1/8" HEAD DIA.	7/8" HEAD DIA.
P	1" HEAD DIA.	1" HEAD DIA.	1" HEAD DIA.
Q	5/8"	1/2"	1/2"
R	1"	1 1/8"	1"
S	2 3/4"	3 1/4"	4"
T	3 3/4"	5 3/8"	7"
U	NO DATA	5 5/8"	7 5/8"
EE	4 1/2"	N/A	N/A
OO	1" DIA.	N/A	N/A

FIGURE 57: PINTLE DATA

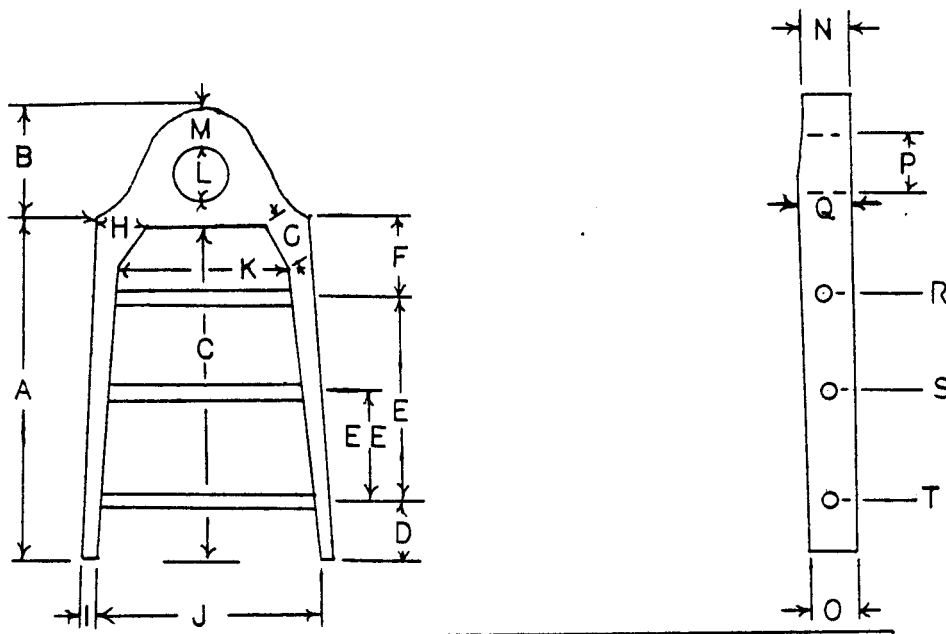

	BOTTOM	MIDDLE	TOP
A	19 1/2"	14 3/8"	9 7/16"
B	4 5/8"	4 9/16"	4 1/4"
C	19 5/8"	14"	9 1/16"
D	2 1/8"	2 3/8"	1 5/8"
E	14 7/8"	8 1/2"	5 3/4"
F	2 5/8"	3 5/8"	2"
G	2 1/2"	2 1/8"	1 5/8"
H	2 1/4"	1 7/8"	2 1/4"
I	3/4"	1/2"	9/16"
J	9 1/8"	9 3/8"	9/4"
K	7 3/8"	7 3/4"	6 7/8"
L	2 3/8"	2 7/16"	2 1/2"
M	1 1/4"	1 9/16"	1 1/8"
N	-	-	-
O	-	3"	-
P	2 3/8"	2 7/16"	2 1/2"
Q	-	3 5/16"	-
R	5/8" DIA	5/8" DIA	1/16"
S	11/16" DIA	N/A	N/A
T	5/8" DIA	5/8" DIA	3/4"
EE	7"	N/A	N/A

FIGURE 58 GUDGEON DATA

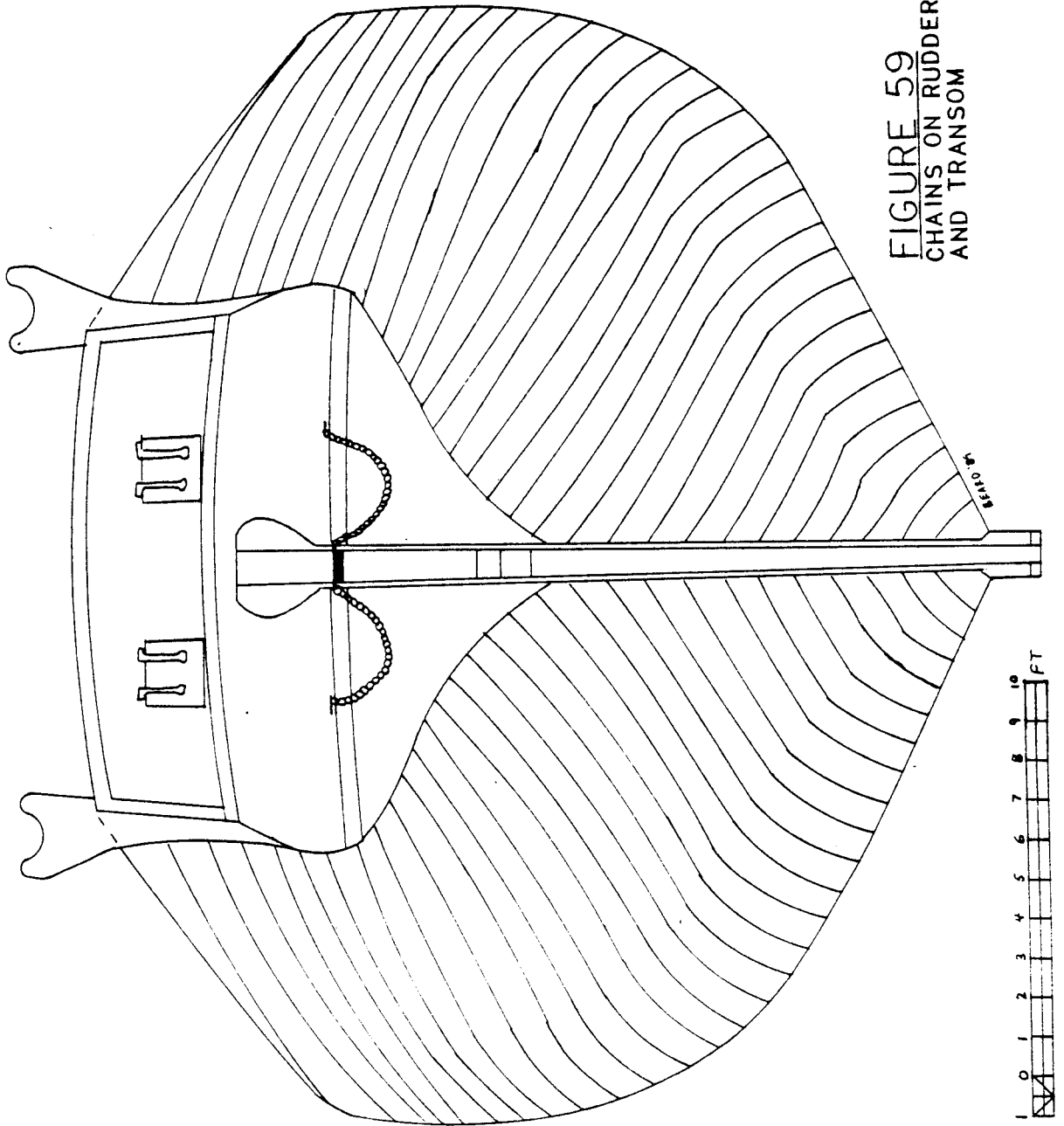

FIGURE 59
CHAINS ON RUDDER
AND TRANSOM

The hardware associated with the rudder is made from a copper and zinc alloy. These fittings consist of three gudgeons (braces), three pintles, one spectacle plate, and numerous large links of copper chain (Fig. 56). The latter two were used to keep the rudder from becoming lost in heavy seas.³⁵

The gudgeons are all of different lengths and widths (Fig. 58). This is due to a reduction in the dimensions of the sternpost, to which they were attached, as it rose from the keel to its upper terminus. Each was attached to the sternpost with either two or three 5/8 inch copper drift pins (Fig. 55b).

The pintles, like the gudgeons, are of different sizes, depending on their location on the rudder (Fig. 55 & 57). They were let into rebates in the rudder and fastened with either three or four 5/8 inch copper drift pins (Figs. 55 & 56a).

The spectacle plate was attached to the rudder near the top of the blade with three copper drift pins. This piece of hardware has two "ears," which are pierced to receive shackles attached to the copper chains (Fig. 56c). An almost identical fitting is to be seen on the rudder of the 100-gun H.M.S. *Victory*, which is on display at Portsmouth, England.³⁶

The copper restraining chain is made up of links that average 4-3/4 inches long, 2-3/4 inches wide and 5/8 inch thick. Several sections and individual links have been recovered. One copper shackle used to attach the chain to the spectacle plate has also been recovered. Other shackles were probably also attached to rings on *DeBraak's* transom as illustrated in Figure 58. Many of the links show signs of extensive wear, and some are worn all the way through. Since it is doubtful that the chain would have been allowed to get into this condition during the vessel's service, it can be

assumed that this wear was caused by the rudder being pushed back and forth by the current motion before the rudder was covered by sand after *DeBraak* sank.

Fasteners

As has been previously mentioned, *DeBraak* was fastened together with a combination of drift pins, spikes and nails (both copper alloy and iron) and wooden trunnels. The copper drift pins range from 3/4 inch to 1-3/8 inches in diameter, averaging 1-1/8 inches. The length of the drift pins ranges from 8-3/4 inches to 8 feet, 6 inches, depending upon which part of the ship they passed through. Many of the drift pins were marked with the Royal Broad Arrow and other markings. One was stamped with the name "FORBES". This suggests that the drift pin was made by the company of William Forbes, a major supplier of copper fittings for the Royal Navy during the late eighteenth century (Appendix C).³⁷ The majority of drift pins in the collection had one end peened over copper roves (washers).

Copper "jag bolts," spikes and nails in a variety of sizes were used throughout the hull. Hull planking was fastened with copper jag bolts, spikes, and wooden trunnels. Copper sheathing and the lead sheathing on the gripe were fastened with smaller copper nails. A number of copper finishing nails were also recovered. Also made of copper were the large staples used to attach the false keel to the keel. Figures 60 and 61 illustrate examples of some of the types of copper and iron fasteners recovered from *DeBraak's* wreck site.

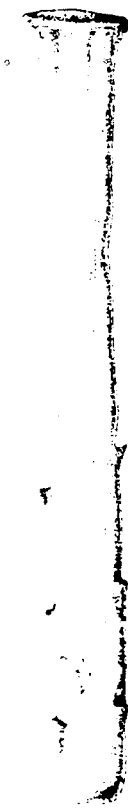
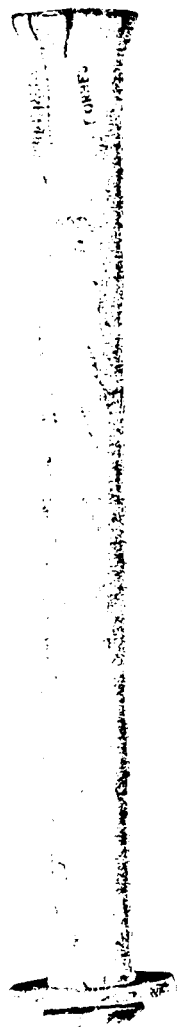
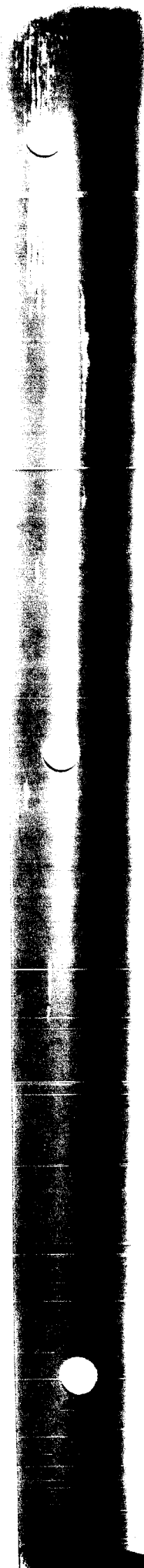

IN.
1 2 3 4 5 6

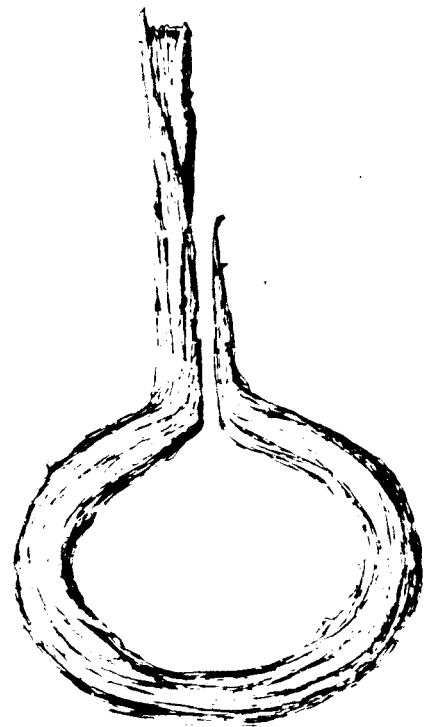

FIGURE 60: COPPER AND IRON BOLTS

(BY WALT LENNINGTON)

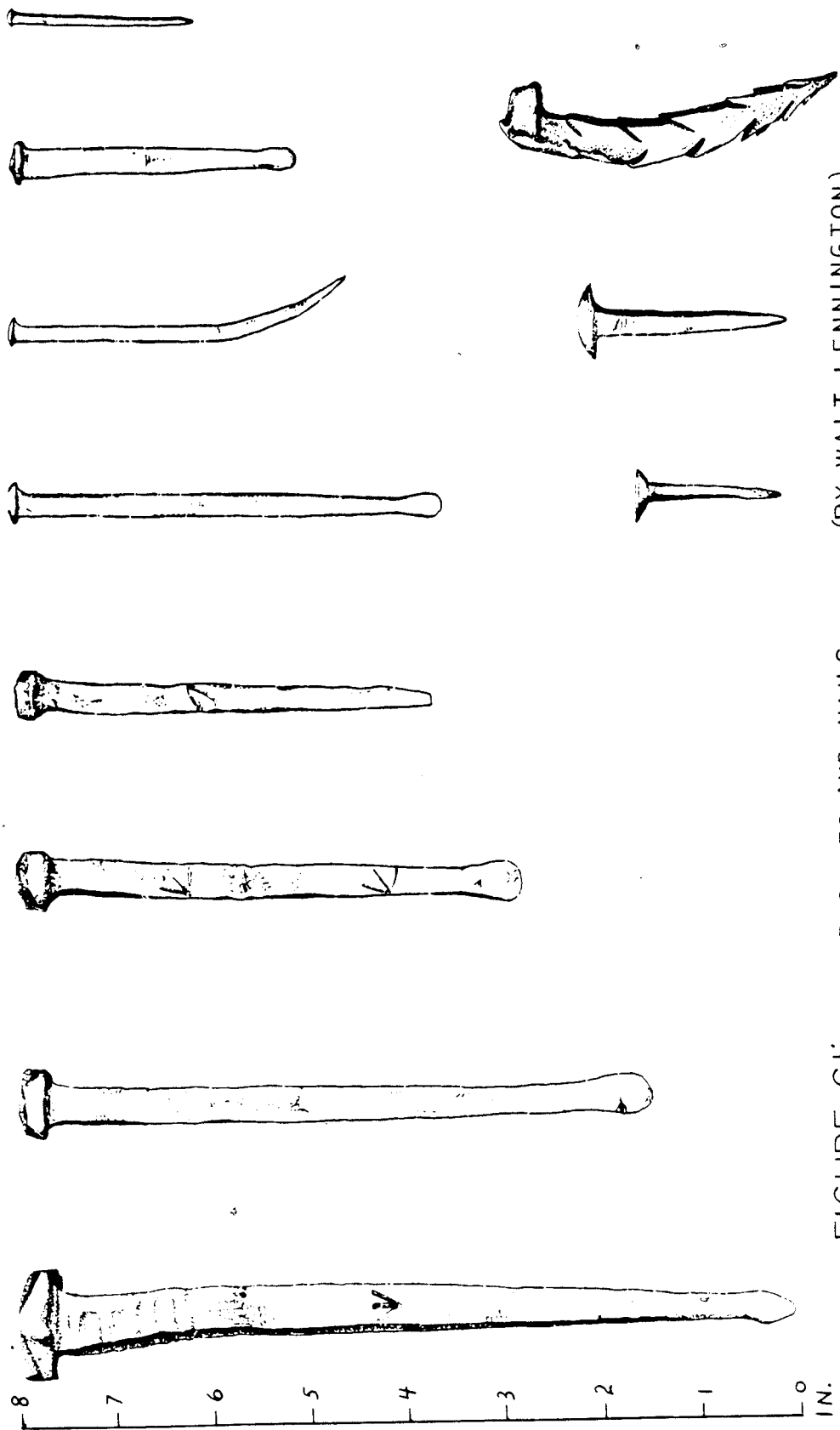

FIGURE 61. COPPER SPIKES AND NAILS (BY WALT LENNINGTON)

Only fragmentary evidence remains about the iron fasteners. Ceiling planks and interior partitions were fastened with 1/4 inch square nails and the cheeks were attached to the keelson with a combination of 1/2 inch square iron spikes and one inch diameter iron drift pins.

Wooden trunnels were used to fasten both hull and ceiling planking. Most of these trunnels have been wedged, although many were not. Of the loose trunnels in the *DeBraak* artifact collection all are eight-sided and have flat (top) ends and rounded (bottom) ends.

Hull Alterations and Repairs

There are numerous indications of alterations and repairs on *DeBraak's* remains. A vessel over twenty years old would surely have had an extensive amount of her original fabric replaced and would require occasional patching and repairing.

In addition to the mast steps and shot lockers, another structural feature added during the refit of 1797 was the riding bitt post aft of the foremast step. An interesting observation about this feature is that the shipwrights made a mistake in cutting its mortice into the ceiling planking and floors. Figure 37a on page 130 shows where a section of ceiling planking was cut out and two mortices cut into adjoining floors. The foremost mortice was cut first and when the mistake was discovered a second one was cut a few inches aft. The mistake was then patched over.

Dryrot was a major problem for wooden ships. *DeBraak* shows numerous signs of this scourge. When dryrot got so bad that the structural integrity of the affected timbers was weakened, those timbers had to be

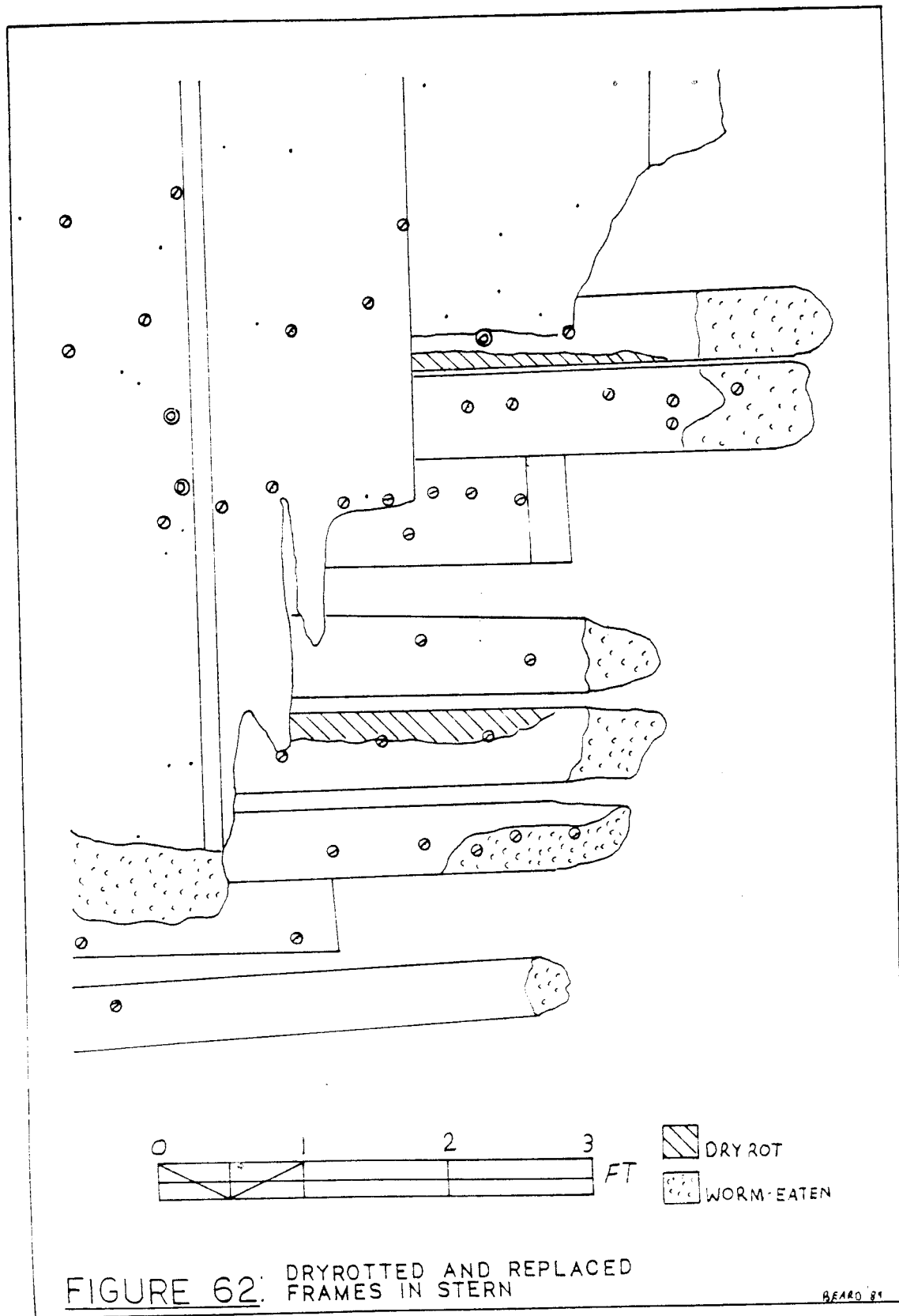
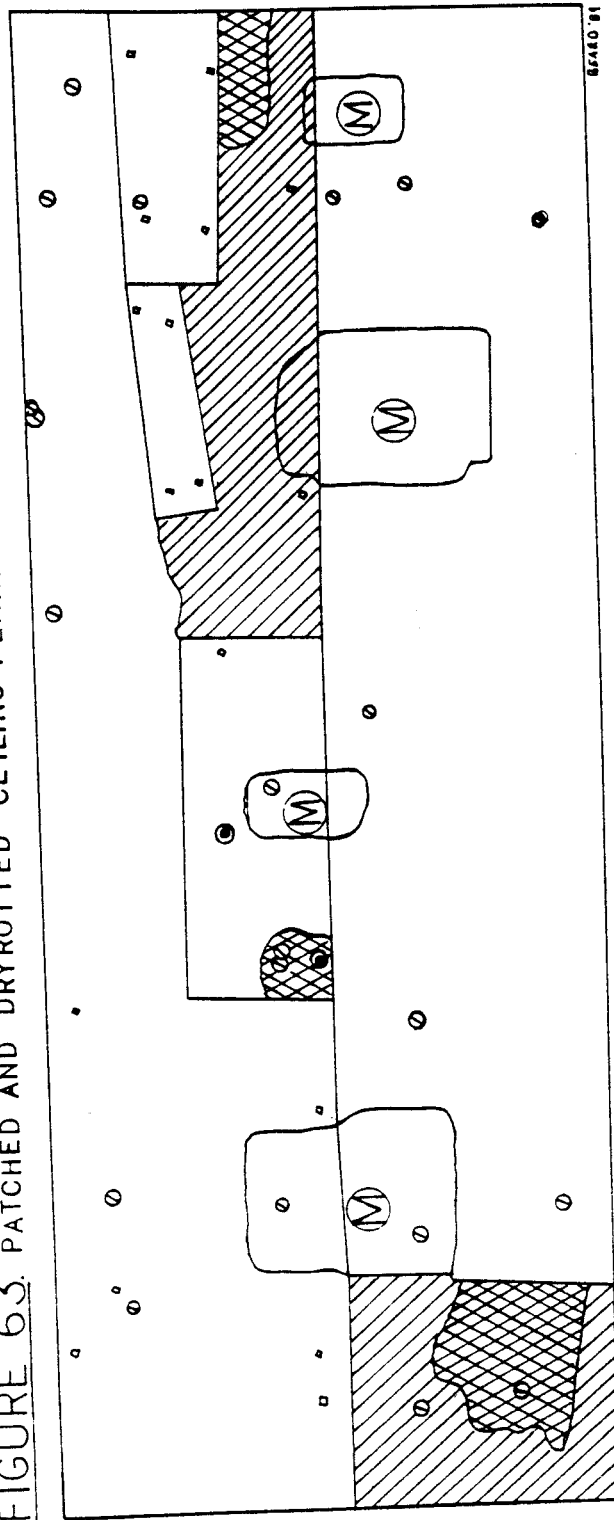

FIGURE 63. PATCHED AND DRYROTTED CEILING PLANK



SEVERE DRY ROT
MODERATE DRY ROT
MORTICE



replaced. Planking, frames, riders, and even major timbers such as the keel, keelson and deadwoods at times had to be replaced. Some ships had almost all of their original timbers replaced during a long career such as *DeBraak's*.

This process may also have been somewhat arbitrary and selective. Wood shortages caused by a war, resulted in the shipwrights being frugal with their timber supply. There is one section of framing in *DeBraak* indicates that some dryrotted futtocks were replaced while others were not (Fig. 62).

There is also a section of ceiling planking that has been repaired in what can best be described as a "patchwork" fashion. A dryrotted plank apparently was repaired by cutting out the rotted areas and inserting patches. Other areas of rot on the same plank appear to have been left (Fig. 63). It seems that it would have been as simple to replace the entire plank. There are three possible explanations for this peculiar patch job. First, it may be that the shipwrights did not want to waste good timber on such an old ship and therefore used a number of small offcuts to repair a non-load-bearing member. Secondly, this plank's location at the level of the hold platform may have made it difficult to remove and replace in one piece. Finally, this may be an example of a shipwright exercising his prerogative of taking home offcuts below a certain size and he felt that he could make better use of a plank that size than patching an old ship.

The top of the keelson also exhibits signs of repair, the purpose of which is not clear. On the central baulk from 4 feet, 4 inches to 9 feet, 3 inches abaft the old cutter mast step, is an area that has been filled in with an odd

FIGURE 64
REPAIRED KEEL AT STERNPOST

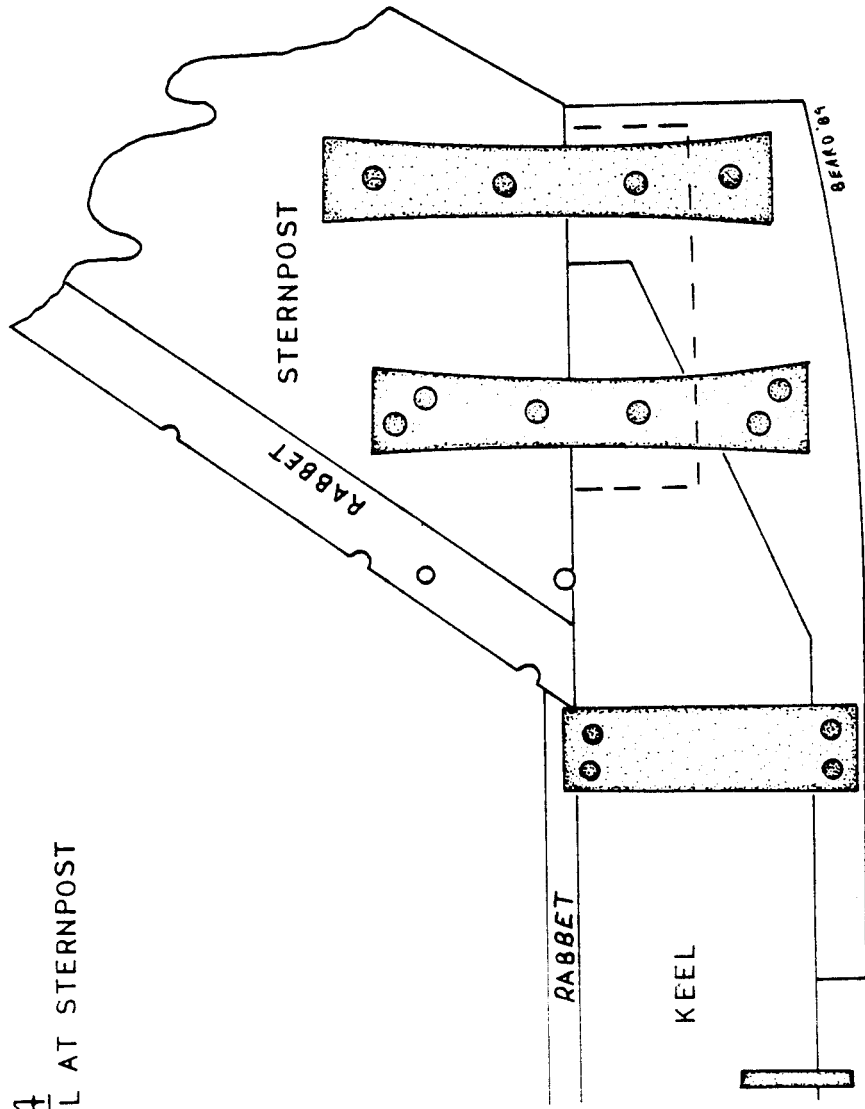

assortment of patches (Fig. 27). These patches are only about 1/2 inch thick and, though their purpose is unclear, may be more cosmetic than functional.

The most interesting repair visible on *DeBraak* is that which was done to the keel at the sternpost. It appears that at some point, possibly while grounding, the keel was damaged where the sternpost is stepped into a mortice. *DeBraak* was then likely taken into drydock or hauled out on the ways for repair. The damaged section of the keel was then cut out and a new section added. This new section also incorporated the aftermost 3 feet, 5 inches of the false keel. The whole area was then fastened together with three copper fish plates (Fig. 64).³⁸

One peculiar repair made to *DeBraak* was apparently carried out after the cutter mast was removed. Faced with the presence of a large mortice in the top of the keelson, the shipwrights had to fill it with something in order to strengthen that point. Logic and common sense would seem to dictate that this hole be filled with a material that would be strong, but at the same time have some "give" to it. The most logical material would be oak or some other hardwood. The crew refitting *DeBraak*, however, decided to fill this mortice with a cast pig-iron ballast bar (Fig. 33, p. 124). These bars weigh about seventy-five pounds and consist of about sixty percent sand and forty percent iron. Not a very flexible material.

Copper Sheathing

DeBraak was sheathed in copper during her refit of May and June of 1798. The Royal Navy had experimented with a number of methods for protecting ship hulls from the devastating effects of boring marine worms (*teredo navalis*). Early methods included lead sheathing and attaching a "false hull" to a ship with a layer of pitch and fibers under it. The former proved to be expensive and heavy and the latter only slowed the inevitable by giving the worms another layer of wood to eat.³⁹

In 1758 copper sheathing was for the first time attached to a Royal Navy warship. The thirty-two-gun frigate H.M.S. *Alarm* was sheathed in copper and the ship sent on a voyage to the West Indies. Although the copper was somewhat successful in protecting the hull from worms and marine growth, it was found that the galvanic action set up by the dissimilar copper sheathing and the iron nails used to hold it in place caused the heads of the nails to be eaten away, and the copper to fall off. Even more alarming was the fact that the iron drift bolts holding the hull together were also degraded where they came into contact with the sheathing, with the result that the structural integrity of the ship was weakened.⁴⁰

The idea of using copper sheathing was abandoned until 1775. The American colonies were in rebellion and the Royal Navy needed to have as many ships available for duty as possible. The number of ships in for cleaning and replanking of hulls put a strain on the ability of the navy to do its job effectively. Experiments with putting lead or thick paper and tar over the heads of the iron bolts proved effective in preventing their corrosion.⁴¹ By the end of 1781 almost the entire English fleet had been sheathed in

FIGURE 65
COPPER SHEATHING ON A THIRTY-TWO GUN FRIGATE

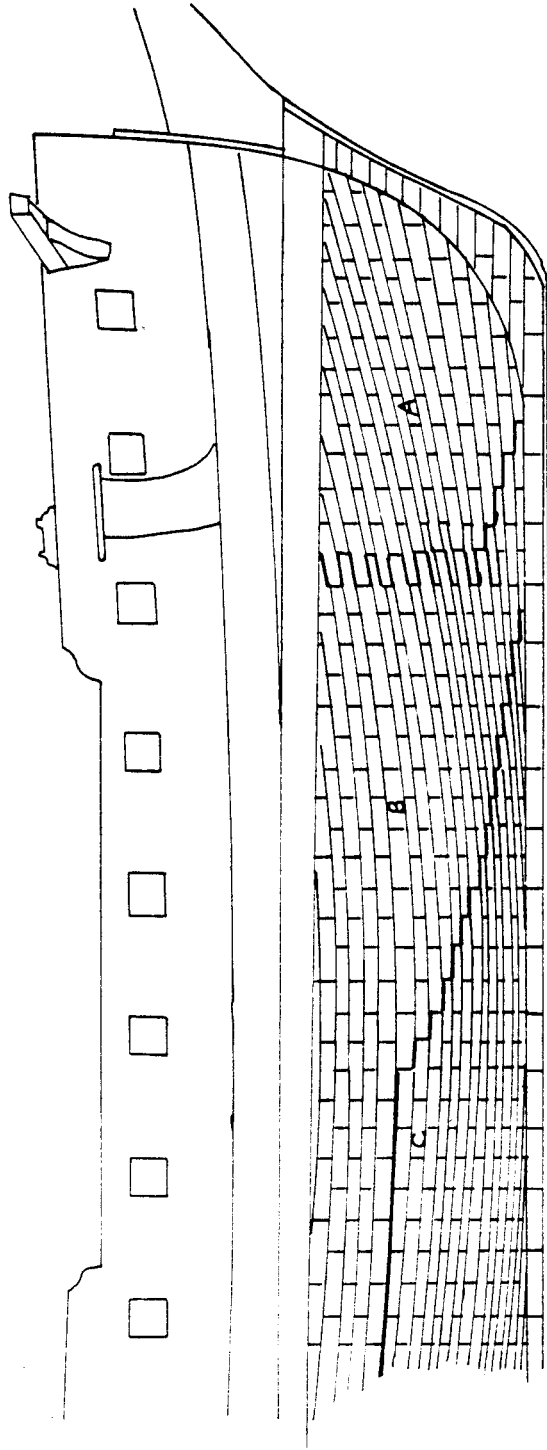

A. 32 OZ. PER SQ. FT.
B. 28 " " " "
C. 22 " " " "

FIGURE 66: EXAMPLES OF DEBRAAK SHEATHING

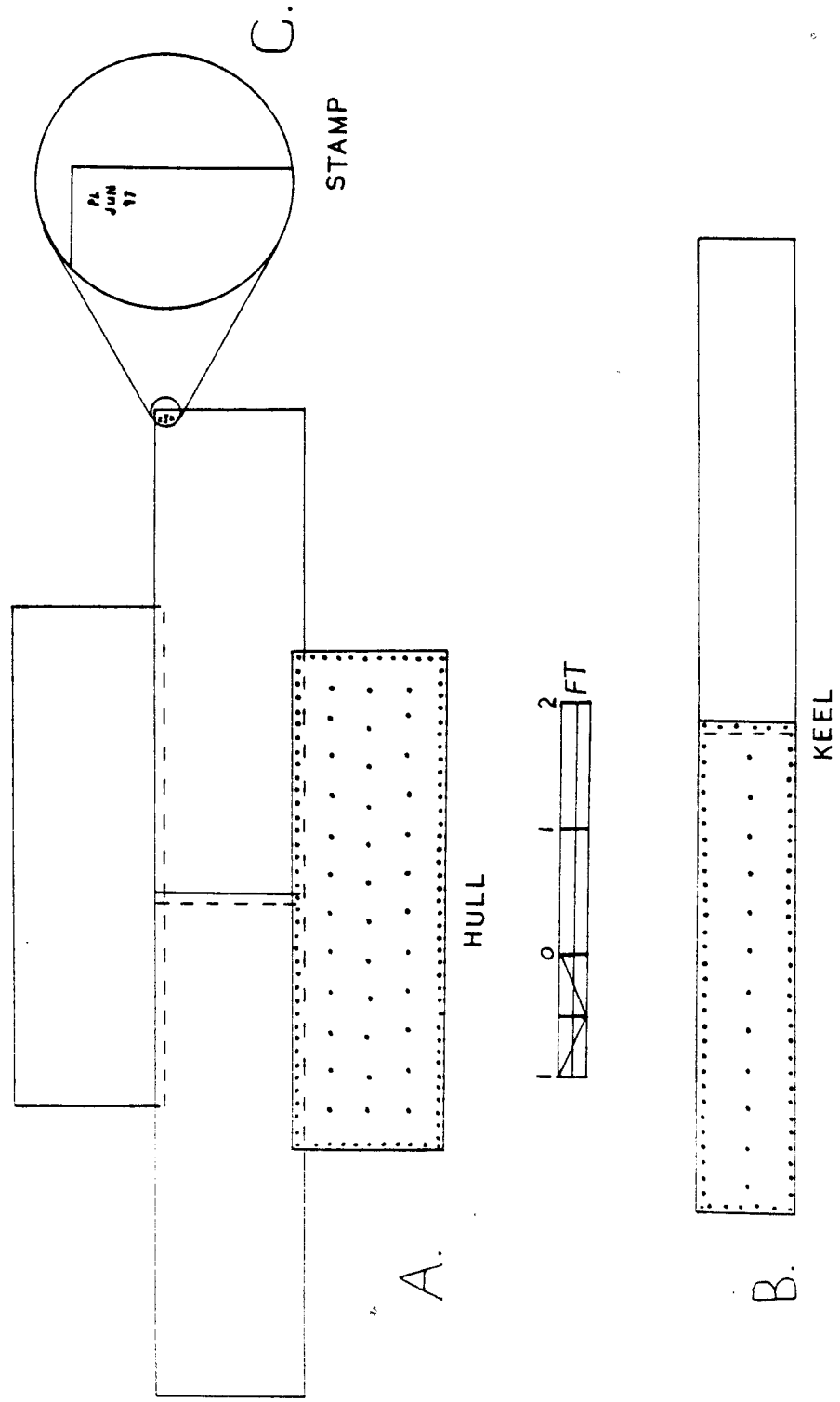

copper, with the exception of some ships on foreign stations.⁴²

Another innovation that allowed the wider use of copper sheathing in the Royal Navy was the introduction of copper and zinc alloy bolts to replace the older iron bolts in fastening ship timbers together. In 1783 the Admiralty adopted the use of this alloy bolt and ships going in for refit had their iron bolts drawn out and replaced with copper.⁴³

DeBraak's sheathing is found intact on almost the entire surviving portions of her starboard side. The weights of the plates on various parts of the hull has not been determined at this point, but they may be similar to those of the thirty-two gun frigate illustrated in Figure 65.⁴⁴

The copper sheets on *DeBraak* average 4 feet long and 14 inches wide. Each sheet is fastened with 134 copper nails, each about 1-1/2 inches long. The nails are spaced 1-1/4 inches on center around the perimeter and 3-3/4 inches on center for the three middle rows. The sheets overlap about 1 inch, with each sheet overlapping the ones above and aft (Fig. 66a).

The sheathing on the sides of the keel consists of sheets 4 feet long and 9 inches wide. These overlap other sheets which cover the bottom of the keel between it and the false keel. Each of the side sheets is fastened with 87 nails, centered 1-1/2 inches on center around the perimeter and 3-3/4 inches down the middle row (Fig. 66b). Many of the copper sheets have stamps in their upper right hand corners indicating that the copper was laid on at Plymouth Yard during June of 1797 (Fig. 66c).

Current Status

DeBraak's hull is currently stored in a freshwater tank in Lewes, awaiting

awaiting final disposition. Negotiations are currently underway between Sub-Sal, Inc. and state officials for the wholesale transfer of the hull and artifact collection to the state. This is dependent upon the salvors' receiving a favorable tax credit for the donation.

There is still a great deal of architectural data to be retrieved from the hull. This study has focused on major structural features and is intended to act as a framework for future research. It is hoped that in the near future the hull will be moved to a more stable environment, where active conservation can begin and a more detailed study can be undertaken.

ENDNOTES

¹David Lyon, personal communication, January 7, 1989. Mr. Lyon is the Head of Enquiry Services at the National Maritime Museum in London.

²Robert G. Albion, Forests and Sea Power, (Cambridge: Harvard University Press, 1926), p. 141. Harry Alden, "A Preliminary Report on *DeBraak* Wood Analysis," (Unpublished report prepared for the Delaware Division of Historical and Cultural Affairs, December 15, 1988), pp. 6-8.

³Alden, "*DeBraak* Wood," p. 7.

⁴David Hebb, personal communication, May 30, 1988. Mr. Hebb is a researcher with the University of London. He related this information to the author while visiting the *DeBraak* Project facility.

⁵Navy Board to Admiralty, September 10, 1796, Admiralty Records 106/2088, Public Record Office, London.

⁶Howard I. Chapelle and Lt. Col. M.E.S. Laws, H.M.S. *DeBraak*: The Stories of a Treasure Ship," Smithsonian Journal of History, Spring, 1967, p. 58.

⁷*DeBraak* "As When Taken" and "As Fitted" plans, Box 65, Registration Numbers 6346 and 6347, National Maritime Museum, London.

⁸E. W. Petrejus, Modelling the Brig-of-War "Irene." (Hengelo-Holland: N.V. Uitgeversmaatschappij "De Esch," 1970), pp. 25-26.

⁹William N. Boog Watson, "Alexander Brodie and His Firehearths for Ships", The Mariner's Mirror, vol. 54, no. 4 (Nov. 1968), pp. 409-410. Brodie invented his firehearth in 1781 and it was quickly adopted by the Commissioners of the Navy for use on Royal Navy vessels. *DeBraak's* stove was recovered by Sub-Sal, Inc. in 1984, but discarded at an unknown location near the wrecksite. A similar stove has been recovered from the wreck of H.M.S. *Pandora* a sixth-rate ship which wrecked on the Great Barrier Reef off Australia in 1792 while returning some of the *Bounty* mutineers to England for trial.

¹⁰Peter Goodwin, The Construction and Fitting of the English Man of War 1650-1850, (Annapolis: Naval Institute Press, 1988), p. 5.

¹¹This dimension is based on a projected extension of the keel's outer surface from known points since the foremost end is badly worm-eaten.

¹²James Dodds and James Moore, Building the Wooden Fighting Ship, (New York: Facts on File, Inc., 1984), p. 58. C. Nepean Longridge, The Anatomy of Nelson's Ships, (Annapolis: Naval Institute Press, 1961), p. 7 states that these scarphs should be 5' long.

¹³This dimension is conjectural, but based on available data.

- 14 Goodwin, Construction and Fitting, p. 7.
- 15 This measurement is conjectural, but based on available data.
- 16 Goodwin, Construction and Fitting, p. 13.
- 17 Alden, DeBraak Wood, p. 7.
- 18 Goodwin, Construction and Fitting, p. 13.
- 19 There is a sirmark on the hog 23' 6 1/2" aft of the foremost end of the keel. This corresponds well with the dead-flat station on *DeBraak's* Admiralty drafts.
- 20 Donald Stokes, personal communication, September 17, 1986. Mr. Stokes has assisted with the documentation of *DeBraak's* hull and is an avocational marine archeologist and ship model builder.
- 21 Goodwin, Construction and Fitting, p. 16. Dodds and Moore, Building, p. 70.
- 22 Goodwin, Construction and Fitting, p. 7.
- 23 Dodds and Moore, Building, p. 68-69 says scarphs should be 5' 6" long. Longridge, Anatomy, p. 23 gives them as 5' 9" long.
- 24 Arthur B. Cohn, ed., A Report on the Nautical Archeology of Lake Champlain. (Burlington: The Champlain Maritime Society, 1984), pp. 62-63.
- 25 Goodwin, Construction and Fitting, pp. 50-51.
- 26 Goodwin, Construction and Fitting, p. 40.
- 27 William "Obie" O'Brian, personal communication. Mr. O'Brian was a diver for Sub-Sal, Inc. from 1984 through 1986.
- 28 David Switzer, personal communication, March 15, 1989.
- 29 Due to the degraded condition of these mortices, the dimensions are approximations.
- 30 Alden, "DeBraak Wood," pp. 7-8.
- 31 Switzer, pers. comm.
- 32 Ronald A. Coleman, "A 'Taylor's' Common Pump from HMS *Pandora* (1791)," The international Journal of Nautical Archaeology and Underwater Exploration, (1988), 17.3, 201-204.
- 33 Switzer, pers. comm.
- 34 Goodwin, Construction and Fitting, p. 66.
- 35 R. J. B. Knight, "The Introduction of Copper Sheathing Into the Royal Navy, 1779-1786," The Mariner's Mirror, vol. 59, no. 3, (August 1973), p. 303. Brian Lavery, The Arming and Fitting of English Ships of War 1600-1815, (Annapolis: Naval Institute Press, 1987), p. 65. The number 24 and

the word **FORBES** was stamped on a pintle recovered from the wreck of H.M.S. *Pandora*

³⁶Longridge, Anatomy, p. 61.

³⁷Knight, "Copper Sheathing," p. 303.

³⁸It is not clear whether or not these fish plates were originally on *DeBraak*, but several of the texts cited in this report show them being used in the construction of new ships.

³⁹Maurer Maurer, "Coppered Bottoms for the Royal Navy: A Factor in the Maritime War of 1778-1783," Military Affairs, vol. 19, no. 2, (1950), p. 58.
Knight, "Copper Sheathing," p. 300.

⁴⁰Knight, "Copper Sheathing." p. 300.

⁴¹Knight, "Copper Sheathing." pp. 300-302.

⁴²Maurer, "Coppered Bottoms.", p. 60.

⁴³Knight, Mirror, p. 306. Dodds and Moore, Building, p. 57.

⁴⁴Navy Board Standing Order of 5 November, 1779, Admiralty Records 106/2472, Surveyor of the Navy to the Master Shipwright, Public Record Office.

CHAPTER VII

SUMMARY AND CONCLUSIONS

It is apparent from the preceding study that the shipwreck located and salvaged by Sub-Sal, Inc. between 1984 and 1986 is that of H.M.S. *DeBraak*, which sank off the coast of Delaware on May 25, 1798. The results of the salvage operation have also definitely concluded, despite the beliefs of the salvors themselves and some long-time residents of Lewes, Delaware, that there never was a substantial treasure on board the ship. The historical documentation alone would have provided this conclusion for anyone who was willing to read it with an open mind, unclouded by fantasies of immense wealth.

The study of *DeBraak*'s history offers a unique look into European naval powers during the last quarter of the eighteenth century and the part played by small, armed vessels in the conflicts between those powers. Despite her obscure origins, she went on to play a role, albeit a small one, in major events which would determine the shape of the European political environment and, later, the Atlantic maritime trade.

Salvage of *DeBraak* offers a classic example of the gross mismanagement of submerged cultural resources in the United States prior to the passage of The Abandoned Shipwrecks Act in 1988. In many ways *DeBraak*'s botched and brutal salvage became the "Remember the Alamo" cry for those fighting to protect historic shipwrecks from the unbridled looting which has been so prevalent in this country during the last quarter century, and may have

contributed in some small way to the passage of the long sought after protective legislation.

Despite the controversy surrounding *DeBraak's* salvage, the study of her hull and associated artifacts offers a unique look into the shipwright's art and the material culture of the Royal Navy during the last quarter of the eighteenth century. Some historic preservation professionals have questioned the ethical propriety of studying this collection due to the stigma associated with the commercial salvage of historic shipwrecks. However, it is the opinion of the author and the other researchers associated with the project that to ignore the available data would be equally as irresponsible as the salvor's actions which destroyed other archeological data from the site. Despite the lack of provenience for the majority of the artifacts, their context is unquestionable and therefore the collection provides very good "benchmark" data which can be used to identify the age and nationality of unknown wrecks which are discovered to contain similar artifact assemblages.

The study of *DeBraak's* hull architecture in particular has offered a chance to acquire information about eighteenth-century ship construction which is available nowhere else. The fact that *DeBraak* was in the service of three different European powers during her career, at least two of which carried out extensive replacement and alteration of her structure during refits, may make this ship somewhat of an architectural mutant.

We have learned from this study that *DeBraak* was a stoutly built ship, constructed for naval or privateering activities which might include withstanding cannon shot. She exhibits certain structural dimensions and

building techniques which indicate that her builders were following to a certain extent the specifications for Royal Navy ships. This could be an indication that the shipwrights who built *DeBraak* had some experience building warships under contract with the Admiralty, or that certain building practices were standard for the period. A good example of this are her keel scarphs which fit exactly the length specification of 4 feet, 6 inches required by the British Admiralty.

DeBraak was an old ship for her size when she sank. Her hull fabric shows signs of rot and the shoddy replacement of timbers, possibly indicating that it was decided that she did not deserve too much attention during her final years. Instead of replacing all dryrotted timbers, only the worst were replaced, allowing the fungus to continue to spread. The haste in which *DeBraak's* conversion was carried out is evidenced by the mistake made in cutting the mortice for one of her riding bitt posts and the irregular fastening of the shot locker components.

On the other hand, these seemingly shoddy repairs may be the result of the pressures of the time, when the naval powers of Europe were stretching resources to their limits, requiring often less-than-ideal maintenance of ships. Many moth-balled vessels in far worse shape than *DeBraak* were refurbished only to the point of being able to stay afloat by means of almost continuous pumping and sent out on blockading and patrol duty.

Although incomplete and preliminary at this point, the study of *DeBraak's* hull has revealed some interesting information about late eighteenth-century ship construction which is not recorded in any historical records or in more recent studies of ships of antiquity. Although much of

the ship's architecture exhibits standard shipbuilding techniques for the period, there are other aspects of her construction which seem very odd or even haphazard. What *DeBraak* can tell scholars about "standard" practices in shipbuilding during this period is incalculable at this point.

The lasting, tangible legacy of *DeBraak* will not be her legendary, and apparently fictitious, hoard of precious metals and jewels, but the wealth of information she has yielded, and will continue to yield, about English naval life in 1798. Specifically, what the material culture of that life was like at 4 o'clock P.M. on May 25, 1798. In this respect, *DeBraak* definitely earns the label "time capsule" which has been used so often to describe the archeological record sealed within shipwrecks.

APPENDIX A

Crew Analysis. H.M.S. *DeBraak*

DeBraak Complement
1797-1798
Officers, Warrants, Seamen

Page 1

Name '97	Rating '97	Casualty '98	Survivor '98	Rating '98	Place of Abode '98
James Drew	Commander	X		Commander	Saltask, Cornwall
William Wade	Purser	X		Purser	Plymouth
William? Rumbold	Gunner	X		Gunner	Gosport
W? Man?	Able				
John O'Neil (O'Neal)	Able			Captain's Clerk	Rath Hale County of Limerick
Issac Dove	Quartermaster Mate		X	Quartermaster	Ipswich, Suffolk
John Breach	Ordinary	X		Ship's Barber	London
Michael? Mahane	Able		X	Seaman	Waterford, Ireland
James Michele? (Samuel Michell)	Quartermaster Mate		X	Yeoman of the Powder Room	New York
William Hearle	Able	X		Midshipman	Plymouth,
? Mitchele Richard (Mitchell)	Clerk	X		Captain's Clerk	Bristol,
Henry Poter (Potr)	Ordinary		X	Ordinary	Plymouth, Devon
John Wade	Midshipman		X	Master's Mate	Plymouth, Devon
Edward? Redman	Carpenter	X		Ship's Carpenter	Plymouth,
William Little	Seaman		X	Seaman	Westbury near Bristol, Gloustershire
Thomas Burman	Ordinary		X	Seaman	Biddeford, Devon
William Satterly	Carpenter's Mate	X		Carpenter's Crew	Plymouth,
Joseph Palser (Joshua Palsey)	Seaman		X	Ordinary	Tilbury, Gloustershire

DeBraak Complement
1797-1798
Officers, Warrants, Seamen

Page 2

Name '97	Rating '97	Casualty '98	Survivor '98	Rating '98	Place of Abode '98
Alexander Lingum (Lingham)	Ordinary		X	Seaman	Glenarm County of Limerick
Hugh Patrick	Ordinary		X	Seaman	Greenock, N.B.
John Walker	Boatswain Mate		X	Boatswain Mate	Exmouth, Devon
William Buss	Ordinary	X		Boy?	Chatham,
Andrew Wilson	Gunner's Mate		X	Gunner's Mate	Poplar, Middlesex
Thomas Griffiths	Master		X	Master	Plymouth, Devon
Alexander Groves	Coxwain				
Thomas Burt	Armorer	X		Armorer	Plymouth,
Mathew Doyle	Seaman		X	Seaman	Bunting Cap County of Wicklow
Stephen Amis (Annis)	Able		X	Seaman	Plymouth, Devon
James Thomas	Yeoman of the Powder Room		X	Boatswain Mate	Bristol Gloustershire
John Levellin (Joseph Lavellam)	Carpenter's Crew		X	Seaman	Plymouth, Devon
Thomas Albrook	Able	X		Seaman	Sweden,
John Morris	Able	X		Seaman	Saltash,
William Day (John)	Able	X		Seaman	Ireland
Ambrose? Biddle	Able		X	Seaman	Birmingham, Warwickshire
John Sweet	Able	X		Seaman	Plymouth,
John Mason	Able		X	Seaman	Plymouth, Devon
Angus Black			X	Ordinary	Rothua? Isle of Burke
William Brookbanks		X		Seaman	Island of Jersey

DeBraak Complement
1797-1798
Officers, Warrants, Seamen

Page 3

Name '97	Rating '97	Casualty '98	Survivor '98	Rating '98	Place of Abode '98
John Bernard?	Seaman	X		Boy?	Colehampton, Devon?
Richard Winter	Ordinary		X	Purser's Steward	Dartmouth, Devon
Edward Edwards	Ordinary	X		Seaman	Plymouth,
Charles Westerly (Westerloff)	Ordinary	X Died at sea		Seaman	Poole, Dorset
James Harrison	Ordinary	X Died at sea		Ordinary	Poole, Dorset
John Leach	Seaman?		X	Ordinary	Port Glasgow, N.B
William? Hurlston (Harlston)	Midshipman	X		Midshipman	London,
William Dobson	Ordinary		X	Ordinary	Brough, Westmorland
William Randle (Randell)	Able	X		Carpenter's Crew	Plymouth,
John May	Ordinary		X	Seaman	Reoruth, Cornwall
William Howard	Carpenter	X		Carpenter	Plymouth,
Thomas Hickson	Lieutenant	X		Lieutenant	Ireland
John White	Surgeon	X		Surgeon	Plymouth,
James Williams	Boatswain		X	Boatswain	Poole, Dorsetshire
William Arundell (Arundell)	Able	X		Midshipman	Ireland
William? Cooper	Cook	X		Cook	Bristol
John Jacobs	Able		X	Seaman	Hamburgh
Archibald McParson	Able		X	Quartermaster	Greenock, N.B.
Thomas Larkins	Ord		X	Landsman	Dublin
John Mills	Seaman	X		Ordinary	North Britain
William Hill			X	Seaman	Woodbury near Exeter
John Marshall			X	Seaman	Have de Grace

DeBraak Complement
1797-1798
Ship's Boys

Page 4

Name '97	Rating '97	Casualty '98	Survivor '98	Rating '98	Place of Abode '98
Thomas Twiggs (Swiggs)	1st Class Boy		X	Boy	Looe, Cornwall
Thomas Devenport (Davenport)	2nd Class Boy	X		Ward Room Steward	Birmingham,
John Mann (Munn)	2nd Class Boy	X		Boy	Colehampton, Devon
William Browne	2nd Class Boy		X	Boy	Cirenster, Gloustershire
James? Ralph	2nd Class Boy		X	Boy	? Cornwall
James Hudd (Hoad)	3rd Class Boy	X		Boy	Bath Lomorganshire
John Pissele?	3rd Class Boy				
John Hyfield	3rd Class Boy	X		listed as "William" Midshipman	Weymouth,
George Hazel (Hapall)	3rd Class Boy		X	Boy	Plymouth Dock

DeBraak Complement
1797-1798
Marines

Page 5

Name '97	Rating '97	Casualty '98	Survivor '98	Rating '98	Place of Abode '98
Moses Williams	Serjeant		X	Serjeant	Birmingham, Warwickshire
James Barnes	Corporal		X	Corporal	Trowbridge, Wiltshire
John Connor	Private		X	Private	Droghely?, Ireland
Joseph Lee	Private		X	Private	Birmingham,
Thomas Smith	Private		X	Private	Trowbridge, Wiltshire
William Morgan	Private		X	Private	Trowbridge, Wiltshire
Michael Hogan	Private		X	Private	Dungarvon, Waterford
Richard Sword	Private		X	Private	Dublin
Jacob Hamilton	Private	X		Marine	Not Stated
James Woodington	Private	X		Marine	Not Stated
William Tozer (Towzer)	Private	X		Marine	Not Stated
Thomas Peary	Private	X		Marine	Not Stated
George Cottereley (Cottrell)	Private		X	Private	Birmingham,
Edward Martin	Private		X	Private	Amluk, Cornwall
Henry Johnson	Supernumerary		X	Private	Spattle Wanbage? Bucks
"Late Porcupine"					

DeBraak Complement
1797-1798

Page 6

MEN'S NAMES NOT FOUND ON H.M.S. DEBRAAK MUSTER TABLE
BUT ARE FOUND ON EITHER SURVIVOR OR CASUALTY LISTS

Name '97	Rating '97	Casualty '98	Survivor '98	Rating '98	Place of Abode '98
John de Costi			X	Seaman	Lisbon, Portugal

APPENDIX B

1986 Lease and Methodology



STATE OF DELAWARE
DEPARTMENT OF STATE
DIVISION OF HISTORICAL AND CULTURAL AFFAIRS
HALL OF RECORDS • DOVER • 19001
(302) 736-5314

OFFICE OF THE DIRECTOR

July 30, 1986

Mr. John L. Davidson
Chief Executive Officer
Sub-Sal, Inc.
P. O. Box 385
Lewes, Delaware 19958

Dear Mr. Davidson:

The following points present the Division of Historical and Cultural Affairs summation of the July 29, 1986 meeting at which representatives of the State and Sub-Sal discussed the latter's "Outline of Procedures for the Salvage of DeBraak Hull and Artifacts, July 27, 1986:"

1. The vessel will be raised to a barge at the earliest possible time in the sequence of the proposed operation. The barge will then be immediately transported to a safe harbor at the Fisher complex to provide maximum time for controlled artifact recovery from the hull and to provide maximum time for recordation of the hull itself. Early raising of the vessel to a barge will also ensure that the hull is not damaged by the dredging operation.
2. Sub-Sal will provide adequate security for the hull and artifacts while they are on the harbored barge.
3. The Division of Historical and Cultural Affairs will prepare an archeological plan for controlled recovery of artifacts from the raised hull and for recordation of the vessel. The Division will supervise and will secure some personnel for implementation of this archeological recovery plan.
4. Sub-Sal will adhere to the archeological recovery plan and will provide personnel to assist the Division of Historical and Cultural Affairs in its timely implementation.

Mr. John L. Davidson
July 30, 1986
Page Two

5. Immediately before the scheduled departure of the crane from the wreck site, at the conclusion of the proposed operations, the vessel on its barge will be transported back to the wreck site. The vessel will be lowered to the ocean bottom at the wreck site, lifted from its cradle, and covered on-site with scoops of ocean floor material deposited by the crane bucket. Reburial of the hull will protect it from structural decomposition which would otherwise proceed rapidly.

In addition to requiring acceptance of the points specified above as discussed in the meeting of July 29, 1986, the Division of Historical and Cultural Affairs requires that the "Outline of Procedures" incorporate the following technical points which were covered at a meeting with Sub-Sal in Lewes on July 25, 1986:

1. In preparation for the first lift, wooden spacers 2" x 6" x 3' will be placed between the hull and slings at the starboard edge of the hull to spread the load and minimize the possibility of damage to the vessel.
2. Buoys on approximately 65' lines will be attached to the bow and stern of the vessel as it lies on the ocean floor prior to the initial lift. The equal height of these buoys beneath the ocean surface will be monitored and maintained carefully during the underwater lift to ensure that the vessel does not tip during its transfer to the cradle.
3. Once the vessel has been placed on its cradle, the entire hull will be wrapped in porous fabric to prevent artifact loss during the surface lift.
4. The lift to surface of the cradled vessel at the recommended rate of 1½ feet per minute will require approximately 60 minutes to complete.
5. Walter Zacharchuk, an underwater archeologist formerly employed by Parks Canada, will be retained by Sub-Sal throughout the entire duration of the crane operation to coordinate responsible implementation of archeological recovery with the Division of Historical and Cultural Affairs.

Mr. John L. Davidson
July 30, 1986
Page Three

It is my understanding that this letter and Sub-Sal's "Outline of Procedures for the Salvage of DeBraak Hull and Artifacts, July 27, 1987" will be appended to the August 1, 1986-July 31, 1987 Salvage Lease for the DeBraak. Satisfactory execution of that lease will require adherence to the Outline of Procedures as modified by the specifications of this letter.

Sincerely,

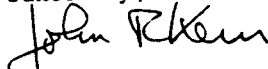

John R. Kern, PhD
Director

cc: Michael Harkins
Michael F. Foster
John Phillips



STATE OF DELAWARE
DEPARTMENT OF STATE
DIVISION OF HISTORICAL AND CULTURAL AFFAIRS
HALL OF RECORDS • DOVER • 19901
(302) 736-5314

OFFICE OF THE DIRECTOR

July 30, 1986

Mr. John L. Davidson
Chief Executive Officer
Sub-Sal, Inc.
P. O. Box 385
Lewes, Delaware 19958

Dear Mr. Davidson:

The following points present the Division of Historical and Cultural Affairs summation of the July 29, 1986 meeting at which representatives of the State and Sub-Sal discussed the latter's "Outline of Procedures for the Salvage of DeBraak Hull and Artifacts, July 27, 1986:"

1. The vessel will be raised to a barge at the earliest possible time in the sequence of the proposed operation. The barge will then be immediately transported to a safe harbor at the Fisher complex to provide maximum time for controlled artifact recovery from the hull and to provide maximum time for recordation of the hull itself. Early raising of the vessel to a barge will also ensure that the hull is not damaged by the dredging operation.
2. Sub-Sal will provide adequate security for the hull and artifacts while they are on the harbored barge.
3. The Division of Historical and Cultural Affairs will prepare an archeological plan for controlled recovery of artifacts from the raised hull and for recordation of the vessel. The Division will supervise and will secure some personnel for implementation of this archeological recovery plan.
4. Sub-Sal will adhere to the archeological recovery plan and will provide personnel to assist the Division of Historical and Cultural Affairs in its timely implementation.

Mr. John L. Davidson,
July 30, 1986
Page Two

5. Immediately before the scheduled departure of the crane from the wreck site, at the conclusion of the proposed operations, the vessel on its barge will be transported back to the wreck site. The vessel will be lowered to the ocean bottom at the wreck site, lifted from its cradle, and covered on-site with scoops of ocean floor material deposited by the crane bucket. Reburial of the hull will protect it from structural decomposition which would otherwise proceed rapidly.

In addition to requiring acceptance of the points specified above as discussed in the meeting of July 29, 1986, the Division of Historical and Cultural Affairs requires that the "Outline of Procedures" incorporate the following technical points which were covered at a meeting with Sub-Sal in Lewes on July 25, 1986:

1. In preparation for the first lift, wooden spacers 2" x 6" x 3' will be placed between the hull and slings at the starboard edge of the hull to spread the load and minimize the possibility of damage to the vessel.
2. Buoys on approximately 65' lines will be attached to the bow and stern of the vessel as it lies on the ocean floor prior to the initial lift. The equal height of these buoys beneath the ocean surface will be monitored and maintained carefully during the underwater lift to ensure that the vessel does not tip during its transfer to the cradle.
3. Once the vessel has been placed on its cradle, the entire hull will be wrapped in porous fabric to prevent artifact loss during the surface lift.
4. The lift to surface of the cradled vessel at the recommended rate of 1½ feet per minute will require approximately 60 minutes to complete.
5. Walter Zacharchuk, an underwater archeologist formerly employed by Parks Canada, will be retained by Sub-Sal throughout the entire duration of the crane operation to coordinate responsible implementation of archeological recovery with the Division of Historical and Cultural Affairs.

Mr. John L. Davidson
July 30, 1986
Page Three

It is my understanding that this letter and Sub-Sal's "Outline of Procedures for the Salvage of DeBraak Hull and Artifacts, July 27, 1987" will be appended to the August 1, 1986-July 31, 1987 Salvage Lease for the DeBraak. Satisfactory execution of that lease will require adherence to the Outline of Procedures as modified by the specifications of this letter.

Sincerely,

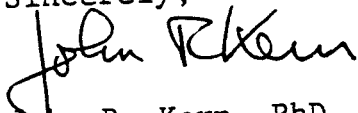

John R. Kern, PhD
Director

cc: Michael Harkins
Michael F. Foster
John Phillips

APPENDIX C











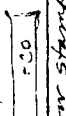

Drift Pin Data

measurements taken from center of markings to nose or flat end
 PROJECT DeBrook CATALOGUER Barclay Spotts DATE 6/8/88 PAGE 1
 necessary notes for head assembly taken on center

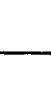
ARTIFACT NO.	ARTIFACT TYPE	MATERIAL	DIMENSIONS	MARKINGS	COMMENTS/DESCRIPTION
86.13.1444.1	drift pin	Copper	10 7/8" L x 3/4" d (nose 1 1/2" d)		nose attached, broad arrow stamp 4 1/2" from nose end
86.13.1444.2	drift pin	Copper	9 3/4" L x 3/4" d (nose 1 1/2" d)		nose attached, broad arrow stamp 5" from nose end
" 3	"	"	11 1/2" L x 3/4" d (nose 1 1/4" d)		nose attached, broad arrow stamp 5 1/4" from nose end (stamp mark faint)
" 4	"	"	10 1/2" L x 7/8" d		no nose, broad arrow stamp 6 3/8" from flat end
" 5	"	"	10 1/2" L x 1 1/2" d		no nose, broad arrow stamp 8" from flat end, around hole 1/2" V mark 4 1/2" from flat end (1A)
" 6	"	"	10 1/2" L x 7/8" d		no nose, broad arrow stamp 4 3/4" from flat end
" 7	"	"	11" L x 1" d (nose 1 3/4" d)		sliding nose from inside, broad arrow stamp 1 1/2" from nose end 5 1/4" from flat end
" 8	"	"	11 3/4" L x 1 1/2" d (nose 2 1/8" d)		sliding nose from inside, broad arrow stamp 10" from flat end
" 9	"	"	8 3/4" L x 1" d (nose 1 3/4" d)		sliding nose, broad arrow stamp 4 1/2" from nose end faint arrow
" 10	"	"	10 3/4" L x 1 7/8" d		no nose, broad arrow stamp 3 1/2" from flat end

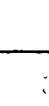
PROJECT DeBorak CATALOGUER Melony Spolito DATE 6/8/88 PAGE 2

ARTIFACT NO.	ARTIFACT TYPE	MATERIAL	DIMENSIONS	MARKINGS	COMMENTS/DESCRIPTION
* 86.13.1444.11	drift pin	Copper	10 1/8" L x 1/4" d (nose 2 3/4" d)		sliding groove attached, broad arrow stamp (3 3/4" and 5 3/4" from nose end)
" 12	"	"	10 3/8" L x 1/4" d (nose 1 7/8" d)		sliding groove attached, broad arrow stamp 1 1/2" from nose end.
" 13	"	"	19 3/8" L x 1/4" d (nose 2 1/4" d)		nose attached, broad arrow stamp 4 1/2" from nose end, VII # 13 3/4" from nose end
" 14	"	"	19 3/4" L x 1/4" d		nose, broad arrow stamp 2 1/2" from flat end
" 15	"	"	20 1/2" L x 1/4" d (nose 1 3/4" d)		nose attached, broad arrow stamp 5 3/4" from nose end
" 16	"	"	20 1/2" L x 1/4" d (nose 1 3/4" d)		nose attached, broad arrow stamp 1 3/4" from nose end
" 17	"	"	21 1/2" L x 1/4" d (nose 2 1/2" d)		2 broad arrow stamps, 2 narrow = tabular stamp 1 1/2" from nose end
" 18	"	"	21 5/8" L x 1/4" d		4 broad arrow stamps, 2 narrow = tabular stamp 1 1/2" from nose end
" 19	"	"	24" L x 1/4" d (nose 2 3/8" d)		nose attached, broad arrow stamp 15 3/4" from nose end
" 20	"	"	20" L x 1/4" d (nose 2 3/8" d)		sliding groove attached, broad arrow stamp 7 3/4" from nose end

ARTIFACT NO.	ARTIFACT TYPE	MATERIAL	DIMENSIONS	MARKINGS	COMMENTS/DESCRIPTION
86.13.1444.21	drift pin	copper	23 1/2" x 1 3/8" d (rove 2" d)	8 CO	etched rove, marking "CO" 18 3/4" from rove end. 
86.13.1444.22	"	"	18 3/4" L x 7/8" d		no rove, broad arrow stamp 16 3/4" from rove end 
" 23	"	"	19 1/2" L x 1 1/2" d (rove 2" d)		sliding rove, broad arrow stamp 6 1/2" from rove end (rove worn) 
" 24	"	"	17" L x 1 1/2" d		no rove, broad arrow stamp at 3 1/2" from flat end, a strike mark 14 1/2" from flat end 
" 25	"	"	22 3/8" L x 1 1/8" d		no rove, broad arrow stamp 21 3/4" from flat end 
" 26	"	"	14 3/4" L x 5/16" d (rove 1 5/8" d)		sliding rove, broad arrow stamp 5 5/8" from rove end 
" 27	"	"	23 1/2" L x 7/8" d (rove 1 5/8" d)		no rove, broad arrow stamp 17" from rove end 
" 28	"	"	17 3/8" L x 1 1/2" d		no rove, broad arrow stamp 17" from rove end
" 29	"	"	17" L x 1 1/8" d		no rove, broad arrow stamp 5 3/4" from rove end
" 30	"	"	17 1/2" L x 1 1/8" d (rove 1 7/8" d)		sliding rove, broad arrow stamp 8 1/2" L from rove end

MEASUREMENTS ON CORNER MARKS

PROJECT de Brak CATALOGUER Beard/Spivack DATE 6/9/88 PAGE 4

ARTIFACT NO.	ARTIFACT TYPE	MATERIAL	DIMENSIONS	MARKINGS	COMMENTS/DESCRIPTION
8613.1444.31	draft pen	Copper	17 1/2" L x 1 3/16" d		no rove, broad arrow stamp 9 3/4" from flat end
.32	"	"	17" L x 1 1/8" d (rove 1 5/16" d)	↗	attached rove, broad arrow stamp 4 1/4" from rove end, 2 thick marks 9" from rove end
.33	"	"	17" L x 1 3/16" d	↙	no rove, broad arrow stamp 16" from flat end
.34	"	"	18 1/2" L x 1 3/16" d (rove 2 1/16" d)	↗	attached rove, broad arrow stamp 12" from rove end
.35	"	"	17 7/8" L x 1 1/4" d (rove 2" d)	↙	attached rove, broad arrow stamp 9 5/8"
.36	"	"	20" L x 1 1/2" d (rove 1 3/4" d)	↘	attached rove, broad arrow stamp 7 5/8" from rove end
.37	"	"	16 1/2" L x 1 1/2" d (rove 1 5/8" d)	↙	attached rove, broad arrow stamp 10 1/2" from rove end
.38	"	"	11 1/2" L x 1" d (rove 1 1/8" d)		attached rove, broad arrow stamp 5 1/2" from rove end
.39	"	"	24" L x 1 1/2" d		attached rove, broad arrow stamp 11 1/2" from rove end
.40	"	"	10 1/8" L x 1 5/16" d		attached rove, broad arrow stamp 5 1/8" from flat end, 3 thick back from at 1 3/4" from end (both in same end) 14 1/2" from rove end at 6" rove 3 from rove end

PROJECT Nebraska CATALOGUER Beard / Spivey DATE 6/14/84 PAGE 5

ARTIFACT NO.	ARTIFACT TYPE	MATERIAL	DIMENSIONS	MARKINGS	COMMENTS/DESCRIPTION
8613.1444.41	drift pin	Copper	10 1/2" L x 1" d	IV	no rivets, Roman numeral 4 to 5 7/8" from flat end
" 42	"	"	9 3/4" L x 7/8" d (rove 1 5/8" d)	IV	attached rove, Roman numeral 4 to 5 7/8" to rove end
" 43	"	"	9" L x 1 1/8" d (rove 2 3/4" d)	I	sliding rove, 1 track mark 4 3/4" from rove end, chisel mark on rove
" 44	"	"	11" L x 1" d (rove 1" to 1 3/4" d " 2" to 1 3/4" d)	III	2 rivets - #1 flat end rove = 2 flat end rove 3 lead marks 6 3/4" from flat end
" 45	"	"	16 7/8" L x 1 3/16" d (rove 2" d)	III	sliding rove, 3 lead marks 10" from rove end
" 46	"	"	20 1/2" L x 1" d (rove 1 1/2" d)	III	attached rove, 3 lead marks 14 1/2" from rove end
" 47	"	"	18 1/2" L x 1 1/16" d (rove 1 7/8" d)	V	excavated rove, Roman numeral 5 or 6 rivets, 2 lead marks, many to 4" from rove end
" 48	"	"	19 3/8" L x 1 1/4" d (rove 1 7/8" d)	CHELL	attached rove, rivets, lead marks NCKELL rove (convict) from rove end
" 49					
" 50					

PROJECT De Beers CATALOGUE Beard / Separable DATE 6/9/88 PAGE 6

ARTIFACT NO.	ARTIFACT TYPE	MATERIAL	DIMENSIONS	MARKINGS	COMMENTS/DESCRIPTION
84442.265.8	drift pin	Copper	11" L x 3/4" d	✓	no nose, broad arrow stamp 1 1/2" from flat end
85.18.430	drift pin	Copper	10 1/8" L x 1" d	→	no nose, broad arrow stamp 2 1/4" from flat end
84442.265.1	"	"	11 3/8" L x 7/8" d (nose 1 3/8")	✓	nose attached, broad arrow stamp 9 3/4" from nose end (sliding nose) (faint marking)
84442.306.C	"	"	10" L x 1 1/16" d (nose 1 5/8" d)	✓	nose attached, broad arrow stamp 2" from nose end (sliding nose)
82.13.62.1	"	"	11 3/4" L x 1 1/16" d (nose 2" d)	✓	nose attached, broad arrow stamp 7 1/4" from nose end
84442.265.1	"	"	10 1/2" L x 1 1/8" d (nose 1 3/8" d)	✓	sliding nose attached, broad arrow stamp 3 1/2" from nose end
84442.265.1	"	"	2 1/4" L x 1 1/4" d (nose 3" d)	✓	nose attached, broad arrow stamp 1/2" from nose end
84442.265.1	"	"	2 3/4" L x 1 1/2" d (nose 2 1/2" d)	✓	nose attached, broad arrow stamp 1 1/2" from nose end
84442.271	"	"	2 3/4" L x 1 1/4" d (nose 5" n)	✓	nose attached, broad arrow stamp 3 5/8" from nose end Stamp with black 3 1/2" from nose end Stamp with arrow stamp on curved end 2 3/4" from nose end, 5/16" mark and 2 1/2" from nose end arrow parallel to nose end

PROJECT de Brank CATALOGUE Melson/Spano DATE 6/9/88 PAGE 7

ARTIFACT NO.	ARTIFACT TYPE	MATERIAL	DIMENSIONS	MARKINGS	COMMENTS/DESCRIPTION
84.442.98D.4	drift pin	silver	19 7/8" L x 1 1/4" d (nose 2 1/8" d)	↙	attached nose, broad arrow stamp 1 1/4" from nose end.
85.18.3085 A	"	"	19 7/8" L x 1 1/4" d (nose 2" d)	↙	attached nose, broad arrow stamp 7" from nose end.
85.18.1699.2	"	"	17 1/4" L x 1 1/8" d	↖	no nose, broad arrow stamp 5 1/2" from flat end.
85.18.3085 E	"	"	20 1/2" L x 1 5/16" d	↑	no nose, broad arrow stamp 19 1/2" from flat end.
86.13.162.1	"	"	23 1/2" L x 1 5/16" d	↗	no nose, broad arrow stamp 12" from flat end.
85.15.1656.1	"	"	22 1/4" L x 1" d	↙	no nose, broad arrow stamp 12 3/4" from flat end.
85.15.1596.2	"	"	23 1/4" L x 1 1/8" d	↙	no nose, broad arrow stamp 14" from flat end.
86.13.162.2	"	"	19 1/2" L x 1 5/16" d	↖	no nose, broad arrow stamp 12 1/2" from flat end.
85.15.1	"	"	19 1/2" L x 7/8" d (nose 1 3/8" d)	↗	attached nose, broad arrow stamp 11 1/2" from nose end.
86.13.159	"	"	24 1/4" L x 1 3/16" d (nose 1 1/2" d)	↙	sliding nose, broad arrow stamp 32" from nose end.

PROJECT Alc. Binak CATALOGUE Beard / Spoolite DATE 6/14/88 PAGE 8

ARTIFACT NO.	ARTIFACT TYPE	MATERIAL	DIMENSIONS	MARKINGS	COMMENTS / DESCRIPTION
85.18.1821	Drift pin	wool	1 1/2" L x 1 5/16" d (rove 1 5/8" d)		attached rove, broad arrow stamp 17" from rove end (paint mark)
86.13.113	"	"	1 9/16" L x 1 3/16" d (rove 1 7/8" d)		attached rove, broad arrow stamp 15 1/2" from rove end.
84.442.34A	"	"	1 9/16" L x 1 1/4" d (rove 1 13/16" d)		attached rove, broad arrow stamp 14" from rove end
85.18.1937.9	"	"	1 9/16" L x 1 1/4" d (rove 1 3/4" d)		attached rove, broad arrow stamp 17 1/2" from rove end (paint mark)
84.442.60B	"	"	20 3/8" L x 1 3/16" d (rove 1 7/8" d)		attached rove, broad arrow stamp 13" from rove end
85.18.261.2	"	"	1 1/2" L x 1 1/4" d (rove 1 15/16" d)		attached rove, Roman numeral 8" from rove end
85.18.261.1	"	"	1 1/4" L x 1 1/2" d (rove 2" d)		attached rove, Roman numeral 5" from rove end
85.18.261.4	"	"	1 1/2" L x 1 3/16" d (rove 2" d)		attached rove, Roman numeral 3, 4, 2, 3 from rove end
85.18.2671	"	"	1 7/8" L x 1 1/4" d (rove 2" d)		attached rove, Roman numeral 3, 4, 4 3/4" from rove end
85.18.1577	"	"	1 6/8" L x 1 3/16" d (rove 1 3/4" d)		attached rove, 4 head marks 7" from rove end

PROJECT McClelland CATALOGUE McClelland/Appendix DATE 6/14/88 PAGE 9

ARTIFACT NO.	ARTIFACT TYPE	MATERIAL	DIMENSIONS	MARKINGS	COMMENTS/DESCRIPTION
85.18.1699.1	drift pin	copper	9 3/4" L x 1 1/2" d (rove 1 7/8" d)	6	sliding rove, broad arrow stamp on rove, 4 slash marks are 6" from rove end
86.13.189	"	"	10 5/8" L x 1 1/2" d (rove 1 7/8" d)		attached rove 1 slash mark, is 1 7/8" from rove end
85.18.3134	"	"	22 1/8" L x 1" d		no rove, 3 slash marks 2 1/4" from flat end.
84442.265.13	"	"	1 1/4" L x 5/8" d (rove 1 3/4" d)	FORBES	attached rove, capital letters FORBES are 10 1/4" (center) from rove end, broad arrow stamp opposite end
				▲	10 1/2" from rove end opposite side



Appendix D
Glossary of Ship Terms

- Apron - The piece of curved timber located behind and affixed to the lower part of the stem, immediately above the foremost end of the keel.
- Ballast - Any heavy material such as stone, sand or iron which is placed in a vessel's hold in order to lower her center of gravity and improve stability.
- Beam - The width of a vessel.
- Bilges - The lowest part of a vessel's hull in which water accumulates.
- Bilge Pump - A mechanism for removing water from a vessel's bilge and discharging it outside the hull.
- Breasthook - Compass timbers fayed athwartships along the after side of the ceiling over the cant frames and hawse pieces in the bow of a ship.
- Bulwark - The framing and planks of a vessel's hull above the uppermost deck.
- Bulkhead - Any partition that divides the interior of a vessel's hold into separate compartments.
- Butt - The squared end of a plank or other timber which unites with the end of another and continues its length.
- Cant Frames - The frames at the ends of a vessel which neither are perpendicular to, nor cross the keel. In the stem they slant forward, while those in the stern slant aft.
- Capstan - A mechanism that turns on a vertical axis in order to take in or let out the anchor cables.
- Ceiling - A vessel's internal planking.
- Cheeks - Thick planks that are laid over the scarphs or butts of composite

timbers to give the joint additional strength.

Compass Timber - Any structural member of a vessel that is carved from a naturally curved piece of wood.

Crutch - A wedge-shaped athwartship timber that butts against the keelson in order to further support a maststep.

Cutwater - The forward most timber of the stem assembly which parts or "cuts" the water as a vessel moves forward.

Deadrise - The angle at which the bottom of a vessel's hull rises above the horizontal plane of the keel.

Deadwood - Any of the timbers bolted to the top of the keel which help compensate for changes in the deadrise.

Drift Pin - A cylindrical bolt made of either iron or copper that is used to fasten together the major timbers of a vessel.

Eye Bolt - A bolt with a circular eye at one end.

False Keel - A timber fastened to the bottom of the keel to protect it from marine parasites and damage.

Fish Plate - A fitting of iron or copper that gives added strength to the joint between two timbers.

Floor Timber - The lowest part of a frame that crosses the keel.

Floor Head - The outboard end of a floor timber.

Frames - The skeleton structures of a vessel, each composed of a floor timber and several futtocks, which are mounted on the keel.

Futtocks - The timbers of a frame which do not cross the keel.

Garboard strake - The lowest external plank of a vessel's hull and is rabbetted into the keel.

Gripe - A curved timber at a ship's bow that is fayed to the foremost end of the keel and stempost. This timber, also called a cutwater, helps a ship "eat" her way to windward.

Gudgeon - A metal strap or brace that is attached to the sternpost and onto which the rudder is hung by means of a pintle.

Gunwale - The upper-most strake or plank of a vessel's side.

Hanging knee - A vertical angled timber that is used to support a vessel's deck beams.

Headsails - The general term for the sails that are situated between the foremast and the bowsprit.

Hog - A deadwood timber that runs along almost the entire length of the top of the keel and is tapered to accept the approach of the garboard strake.

Keel - The main longitudinal structural member of a vessel to which the frames, stempost, sternpost, and deadwoods are fastened.

Keelson - The major interior longitudinal member that sits atop the frames along the same line as the keel.

Larboard Side - Another term for the port or left side of a vessel.

Limber Holes - Holes cut into the floor timbers and first futtocks to allow water to run along the top of the keel and into the bilge for removal by pumps.

Mast Step - The structure into which the foot of a mast is fitted in order to more evenly distribute the weight of the mast over the keelson.

Midship Frame - The frame at the widest point of a vessel. On plans this point is marked with the symbol O.

Mortice - A cavity that is cut into the surface of one timber in order to accept the tenoned end of another.

Molded - The measurement of height or depth of the timbers in a vessel.

Necessary - A lavatory or head aboard a ship. In *DeBraak's* case this was simply a small stern cabin with a round scuttle (hole) in its floor.

Pintle - A metal strap with a pin which is attached to the rudder and fits into a gudgeon, forming a hinge on which the rudder swings.

Port Side - The left side of a vessel when looking forward.

Rabbet - A groove that is cut into the keel, stempost and sternpost to form a seat for the garboard strake.

Riders - Interior ribs that are fayed upon the ceilingplanking. A large warship would have one set of riders for each futtock, but *DeBraak* has only lower and upper riders.

Riding Bitts - A set of timbers consisting of two upright posts and a cross-piece to which the anchor cables are secured.

Room and Space - The distance between the face edge of a frame to the equivalent face edge of the next frame.

Rove - A small circular washer that is placed over a bolt or nail before peining.

Scantlings - The major timbers in a vessel's hull.

Scarph - A joint that connects two timbers by over-lapping.

Scupper - A lead-lined drain hole in a vessel's side through which water is discharged from the upper decks.

Sheathing - A material such as wood, lead, or copper that is used to cover a vessel's hull in order to protect it from marine parasites.

Sheer - The longitudinal curve of a vessel's hull as seen from the side.

Siding - The measurement across the top of a frame or longitudinal

timbers.

Spectacle Plate - A metal fitting located near the top of a rudder's blade to which preventer chains are fastened.

Square Frame - A frame that is perpendicular to the keel and extends across the sides of the hull.

Stanchion - An upright supporting post.

Starboard Side - The right side of a vessel when looking forward.

Stealer - A plank whose width diminishes fore or aft to compensate for the curvature of a vessel's hull.

Stempost - The upward-curving timber which is the forward-most integral perpendicular of a vessel into which the two side of the bow are united.

Stern Knee - A knee that reinforces the join between the deadwoods and the sternpost.

Sternpost - The aftermost perpendicular of a vessel which is secured at its base to the keel and at its top to the transom.

Stopwater - A wooden dowel driven across a seam between two timbers to prevent water from traveling between them.

Strake - A continuous line of planks which extends from the stem to the stern of a vessel.

Stringer - A longitudinal structural member within the interior of a ship.

Thickstuff - As the name implies, these are thicker strakes located at the joint between futtocks, giving added strength to that area.

Top Timbers - The upper-most futtocks of a frame.

Transom - The transverse timbers which give shape to and form the stern.

Trunnel - From the term "treenail," this is a wooden fastener used to join a vessel's timbers.

Waterway - A curved plank that runs along the base of the bulwark of a vessel's interior along which water is channeled to the scuppers.

BIBLIOGRAPHY

PRIMARY SOURCES

Manuscripts

Admiralty In Letters, Admiralty Records 1/1714, Public Record Office, London.

Admiralty In Letters, Admiralty Records 1/1719, Public Record Office, London.

Captains' Letters "D", Admiralty Records 1720, Public Record Office, London.

Captains' Letters "T", ref. 31.1-Damage and Loss at Sea, 103 Gen., Cap T 137, Admiralty Records 1/2599, Public Record Office, London.

Special File Proposed Salvage of *DeBraak*, Admiralty Records 1/5121/3, Public Record Office, London.

Navy Board Out Letters, Admiralty Records 2/374, Public Record Office, London.

Secretary's Letters to Commanders in Chief, Halifax 1795-1807, Admiralty Records 2/931, Public Record Office, London.

Admiralty Out Letters, Admiralty Records 2/1099, Public Record Office, London.

Certificates of Service, Masters c. 1800-1850 D-G, Admiralty Records 6/147, Public Record Office, London.

H.M.S. *DeBraak* Pay Book, January 9, 1801, Admiralty Records 35/211, Public Record Office, London.

H.M.S. *DeBraak* Pay Book, May 14, 1822, Admiralty Records 35/211, Public Record Office, London.

H.M.S. *Assistance* Muster Books 1798-1799, Admiralty Records 36/13099, Public Record Office, London.

H.M.S. *Assistance* Captains' Logs 5 June, 1798-4 June, 1799, Admiralty Records 51/1258, Public Record Office, London.

H.M.S. *St. Albans* Captains' Logs 26 May, 1797-September 16, 1798, Admiralty Records 51/1272, Public Record Office, London.

H.M.S. *Hind* Captains' Logs 17 May, 1798-17 May, 1799, Admiralty Records 51/1296, Public Record Office, London.

H.M.S. *Assistance* Masters' Logs 14 May, 1798-13 May, 1799, Admiralty Records 52/2725, Public Record Office, London.

Navy Board to Admiralty, Admiralty Records 106/2088, Public Record Office, London.

Surveyor of the Navy to the Master Shipwright, Admiralty Records 106/2472, Public Record Office, London.

DeBraak Plans, Registrations 6346 and 6347, Box 65, National Maritime Museum, London.

Printed Government Documents

Clark, William Bell, ed. Naval Documents of the American Revolution. Washington: United States Department of the Navy, 1968. III.

Newspapers

Philadelphia Gazette, May 28, 1798.

South Carolina Gazette and Timothy's Daily Advertiser, June 13, 1798.

Steele's Navy Lists, March 6, 1800.

SECONDARY SOURCES

Books

- Albion, Robert G. Forests and Sea Power. Cambridge: Harvard University Press, 1926.
- Black, Jeremy and Philip Woodfine, eds. The British Navy and the Use of Naval Power in the Eighteenth Century. Leichester: Leichester University Press, 1988.
- Cohn, Arthur B. A Report on the Nautical Archeology of Lake Champlain. Burlington: The Champlain Maritime Society, 1984.
- Dodds, James and James Moore. Building the Wooden Fighting Ship. New York: Facts on File, Inc., 1984.
- Goodwin, Peter. The Construction and Fitting of the English Man of War 1650-1850. Annapolis: Naval Institute Press, 1988.
- Kossman, E.H. The Low Countries: 1780-1940. Oxford: Clarendon Press, 1978.
- Lavery, Brian. The Arming and Fitting of English Ships of War 1600-1815. Annapolis: Naval Institute Press, 1987.
- LeFebvre, Georges. The French Revolution From 1793 to 1799. Trans. John Hall and James Friguglietti. Washington: Columbia University Press, 1964.
- Longridge, Nepean C. The Anatomy of Nelson's Ships. Annapolis: Naval Institute Press, 1961.
- Marcus, G.J. A Naval History of England: The Formative Centuries. London: Longmans, 1961.
- McKee, Alexander. History Under the Sea. London: Hutchinson & Co., 1968.
- Palmer, Michael. Stoddert's War: Naval Operations During the Quasi-War With France 1798-1801. Columbia: University of South Carolina Press, 1987.
- Petrejus, E.W. Modelling the Brig-of-War "Irene". Henglo-Holland: N.V. Uitgeversmaatschapij "De Esch," 1970.

Articles

- Chapelle, Howard I. and Lt. Col. M.E.S. Laws. "HMS *DeBraak* The Stories of a 'Treasure Ship'." Smithsonian Journal of History, Spring, 1967.
- Coleman, Ronald A. "A Taylor's Common Pump from HMS *Pandora* (1791)," The International Journal of Nautical Archaeology and Underwater Exploration, 1988, 17.3.
- Knight, R.J.B. "The Introduction of Copper Sheathing into the Royal Navy, 1779-1786," The Mariners' Mirror, vol. 59, no. 3.
- Maurer, Maurer. "Coppered Bottoms for the Royal Navy: A Factor in the Maritime War of 1778-1783," Military Affairs, vol. 19, no. 2, (1950).
- Watson, William N. Boog. "Alexander Brodie and His Firehearths for Ships," The Mariners' Mirror, vol. 54, no. 4.

Unpublished Manuscripts

- Alden, Harry A. "A Preliminary Report on *DeBraak* Wood Analysis." An unpublished report prepared for the Delaware Division of Historical and Cultural Affairs, December 15, 1988.
- Beard, David V. "The *DeBraak* Recovery Project: Winter Operations, 1986." An unpublished report prepared for the Delaware Division of Historical and Cultural Affairs, May, 1986.
- Beard, David V. "The *DeBraak* Recovery Project: A Preliminary Report on Summer-Fall 1986 Operations." An unpublished report prepared for the Delaware Division of Historical and Cultural Affairs, April, 1987.
- Ward, H. Henry, David V. Beard and Claudia F. Melson. "Preliminary Report on Archaeological Monitoring of the Salvage Activities on the H.M.S. *DeBraak*, 1985." Unpublished report printed by the University of Delaware Center for Archaeological Research, February, 1986.

Newspapers

Evening Journal, Wilmington, Delaware, February 16, 1937 and July 18, 1956.

Morning News, Wilmington, Delaware, August 3, 1965 and November 5, 1973.

Saturday Evening Post, February 13, 1954.

Sunday Bulletin, Baltimore, Maryland, March 20, 1969.

The Whale, Rehoboth Beach Delaware, October 22, 1980.

Personal Communications

Harrington, Harvey. April 10, 1988.

Hebb, David. May 30, 1988.

Hopkins, Fred. August 25, 1986.

Hopkins, Fred and Donald Shomette. n.d.

Lyon, David. January 7, 1989.

Marshall, Ronald. n.d.

O'Brian, William. n.d.

Pizzuto, James. n.d.

Stokes, Donald. September 17, 1986.

Switzer, David. March 15, 1989.